



Surface Pro 8 Service Guide



Disclaimer of Warranties and Limitation of Damages

All information, content, materials, and products made available in or in conjunction with this Manual are provided by Microsoft on “as-is” and “as available” basis, unless otherwise specified by Microsoft in writing. Microsoft makes no representations or warranties of any kind, express or implied, as to the information, content, materials and products included or otherwise made available to you or accompanying this Manual unless specified in writing. You expressly agree that your use of the information, content, materials, and product in or accompanying this Manual is at your sole risk.

To the fullest extent permissible by law, Microsoft disclaims all warranties, express or implied, including but not limited to implied warranties of merchantability and fitness for a particular purpose. To the fullest extent permissible by law, Microsoft shall not be liable for damages of any kind arising from the use of information, content, materials, or product made available in or in conjunction with this Manual, including but not limited to direct, indirect, incidental, consequential, and/or punitive damages unless otherwise specified in writing.

Notice

Microsoft and its suppliers may have patents, patent applications, trademarks, copyrights, trade secrets and/or other intellectual property rights covering subject matter in this document. Microsoft’s furnishing of this document to recipient does not grant or imply any license to any patents, trademarks, copyrights, trade secrets or other intellectual property rights, and recipient’s permitted use of any such intellectual property rights, if any, is solely governed by the Agreements.

This document and the information it contains are subject to change without notice. You can find the latest information on Surface device servicing and repair at <https://aka.ms/surfaceservicing>. Always consult the most up-to-date information available before performing device servicing or repair.

©2023 Microsoft Corporation. All rights reserved.

Document Part Number: M1196218_RevC



TABLE OF CONTENTS

DEVICE IDENTITY INFORMATION	4
• SURFACE PRO 8 MODELS.....	4
• GLOSSARY OF TERMS	5
GENERAL INFORMATION, PRECAUTIONS, WARNINGS	6
• SERVICE TOOLS AND JIGS	6
• GENERAL SAFETY PRECAUTION	7
• REPAIR-SPECIFIC PRECAUTIONS AND WARNINGS	8
BATTERY SAFETY	9
LITHIUM-ION BATTERY INSPECTION	10
• HANDLING USED, DAMAGED, OR DEFECTIVE LITHIUM-ION BATTERIES:.....	10
• REPORT BATTERY THERMAL EVENTS TO MICROSOFT.....	11
• ACTIONS TO TAKE:.....	11
• STOP REPAIR AND CONTACT MICROSOFT	11
ILLUSTRATED SERVICE PARTS LIST	12
SERVICE DIAGNOSTICS/TROUBLESHOOTING OVERVIEW	13
• SOFTWARE TOOLS:	13
• RSSD TROUBLESHOOTING APPROACH:	13
COMPONENT REMOVAL AND REPLACEMENT PROCEDURES	14
• PRIOR TO DEVICE DISASSEMBLY	14
• RSSD REPLACEMENT PROCESS	15
• PRELIMINARY REQUIREMENTS.....	15
• REQUIRED TOOLS AND COMPONENTS.....	15
• PREREQUISITE STEPS:.....	15
• PROCEDURE – REMOVAL (RSSD)	15
• PROCEDURE – INSTALLATION (RSSD)	16
• SWAP RSSD TO A NEW DEVICE PROCESS	18
• PRELIMINARY REQUIREMENTS.....	18
• REQUIRED TOOLS AND COMPONENTS.....	18
• PREREQUISITE STEPS:.....	18
• PROCEDURE – SWAP (RSSD).....	19
• KICKSTAND REPLACEMENT PROCESS.....	23
• PRELIMINARY REQUIREMENTS.....	23
• REQUIRED TOOLS AND COMPONENTS.....	23
• PREREQUISITE STEPS:.....	23
• PROCEDURE – REMOVAL (KICKSTAND)	23
• PROCEDURE – INSTALLATION (KICKSTAND)	26
• TDM REPLACEMENT PROCESS.....	30
• PRELIMINARY REQUIREMENTS.....	30
• REQUIRED TOOLS AND COMPONENTS.....	30
• PREREQUISITE STEPS:.....	31
• PROCEDURE – REMOVAL (TDM)	31
• PROCEDURE – INSTALLATION (TDM)	36
• PROCEDURE – ALTERNATE INSTALLATION (TDM)	40
• THM REPLACEMENT PROCESS	44
• PRELIMINARY REQUIREMENTS.....	44
• REQUIRED TOOLS AND COMPONENTS.....	44
• PREREQUISITE STEPS:.....	44
• PROCEDURE – REMOVAL (THM)	45
• PROCEDURE – INSTALLATION (THM).....	48
• SURFLINK REPLACEMENT PROCESS.....	52
• PRELIMINARY REQUIREMENTS.....	52
• REQUIRED TOOLS AND COMPONENTS.....	52
• PREREQUISITE STEPS:.....	52
• PROCEDURE – REMOVAL (SURFLINK)	53
• PROCEDURE – INSTALLATION (SURFLINK)	55
ENVIRONMENTAL COMPLIANCE REQUIREMENTS	57



Introduction

This Service Guide (Guide) provides instructions for repairing Microsoft Surface devices using genuine Microsoft parts. It is intended for technically inclined individuals with the knowledge, experience, and specialized tools required to repair Microsoft devices.

 **IMPORTANT:** Read this Guide in its entirety before starting any repairs. If at any point you are unsure or uncomfortable about performing the repairs, as detailed in this Guide, **DO NOT** proceed. Contact [Microsoft](#) for additional support options.

 **WARNING:** Failure to follow the instructions in this Guide; use of non-Microsoft (non-genuine), incompatible, or modified replacement parts; and/or failure to use proper tools could result in serious personal injury, death, and/or damage to the product or other property.

Device Identity Information

Surface Pro 8 Models

1982 – Surface Pro 8 LTE (Platinum)

1983 – Surface Pro 8 WiFi (Platinum and Graphite)

The rSSD drive size and serial number for Surface Pro 8 are located under the kickstand.

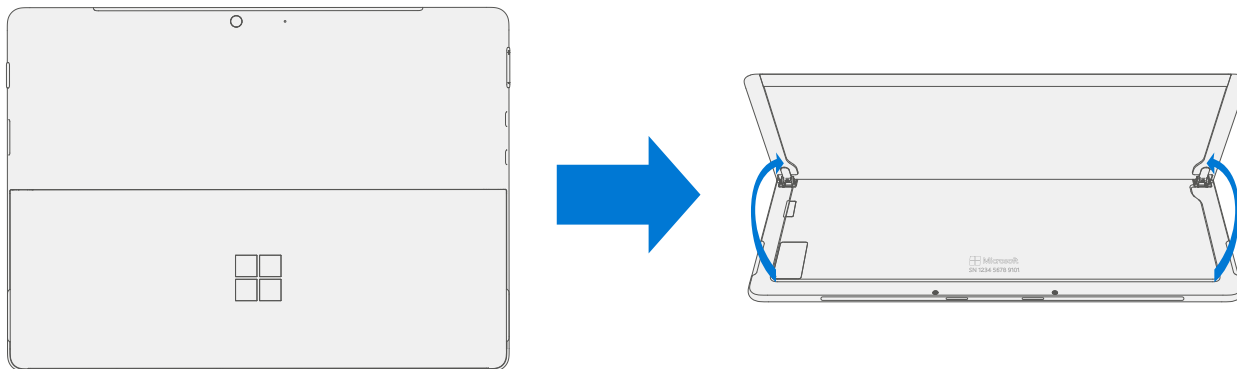

Glossary of Terms

The following terms are used throughout this manual

- **rSSD** – Removable Solid-State Drive
- **TDM** – Touch Display Module is the complete screen with all layers.
- **THM** – Thermal Module is an assembly with heat spreaders and electric fan.
- **TIM** – Thermal interface material used between the THM and PCBA.
- **PCBA** – Primary circuit board assembly
- **SoC** – System-on-a-chip is a microchip with several electronic circuits and parts on a single integrated circuit.
- **PSA** – Pressure Sensitive Adhesive
- **IBC** – Tablet Back Cover
- **BMR** – Bare Metal Recovery refers to the clean imaging process.
- **SDT** – Surface Diagnostic Toolkit
- **ESD** – Electro-Static Discharge
- **FRU** – Field Replaceable Units are sub-system components such as the SIM/rSSD door, Kickstand, and rSSD. FRUs are available only to ASPs. Some replaceable units will only be available as FRUs and therefore are only supported at an ASP.
- **Commercial Spares/CRU** – Customer Replaceable Units available to commercial customers for repair by a skilled-technician.



General Information, Precautions, Warnings

 This symbol identifies important safety and health information in this manual.

 This symbol identifies important information in this manual.

 This symbol identifies important cautions in this manual.

Service Tools and Jigs

Microsoft Service Tools

- SIM eject tool (or equivalent 0.023 in / 0.58 mm diameter paperclip)
- Surface dock
- TDM PSA debonding tool (M1214770-001)
- TDM PSA bonding frame (M1178722-001)
- Surface Diagnostic Toolkit

Standard Service Tools

- Anti-static wrist strap (1 MOhm resistance)
- Soft Electro-Static Discharge (ESD) safe mat
- iFixit pick
- iFixit opening tool
- Spudger
- Two 2 in spring clamps
- TDM Bonding weight
 - Weight Requirement: minimum 23 kg (50 lb) / maximum 26 kg (57 lb)
 - Minimum Dimensions: 280 mm x 200 mm (11 in x 8 in)
 - Geometry must be symmetrical, to allow for even weight distribution.
 - Weight used must be a flat plate, with consistent flatness and not protrude from contact plane with Bonding Frame.
 - Weight must contact the full perimeter of the frame when placed above it.
 - Recommended weights Ruck Plates of 9 kg + 14 kg (20 lb + 30 lb)
- Foam pad
 - Material: EVA Foam
 - Thickness: 9.5 mm (3/8 in)
 - Density: 0.03 g/cm³ (2 lb/cu Ft)
 - Dimensions: Minimum 229 mm x 305 mm (9 in x 12 in)
 - Recommended foam pad (McMaster PN: [86095K43](#))
- 3IP and 6IP (Torx-Plus) drivers
- Loctite SF 7649
- Loctite 243
- Isopropyl alcohol dispenser bottle (use 91% or greater IPA)
- Cotton swab
- USB drive
- Wired Ethernet connection to the Internet
- USB keyboard
- Microfiber / lint free cloth

The tools identified on this list can be purchased from many different commercial sources, including but not limited to Amazon.com; iFixit; Chemdex, and other vendors. Refer to the ASP Guidebook for Microsoft tools.



General Safety Precaution

 Always observe the following, general safety precautions:

- Opening and/or repairing any electronic device can present a risk of electric shock, fire, serious personal injury, death, damage to the device or other property, and/or other hazards. Exercise caution when undertaking the repair activities described in this Guide. The repair activities identified in this Guide should only be undertaken by technically inclined individuals with the knowledge, experience, and specialized tools required to repair Microsoft devices.
- Improper use or handling of devices or their batteries may result in fire or explosion. Only open the enclosure on a device as outlined in this Guide.
- Do not heat, puncture, mutilate, or dispose of devices or their batteries in fire. Do not leave or charge devices in direct sunlight or expose devices or their batteries to temperatures outside the recommended operating range of 0°C to 60°C/32°F to 140°F for an extended period. Doing so can result in battery failure, electric shock, fire, serious personal injury, death, and/or damage to the device or other property.
- We recommend wearing protective eyewear and gloves when disassembling/re-assembling a device.

For additional product safety information relevant to Microsoft Surface devices, see aka.ms/surface-safety or the Surface app. To open the Surface app, select the Start button, enter Surface into the search box, then select the Surface app.



Repair-Specific Precautions and Warnings

- For Autopilot managed Surface Products refer to the following guidelines posted here.

 **WARNING:** Before opening a device, ensure it is powered off and disconnected from its power source. Disconnect the device charger or power cord from mains power.

- For devices with rechargeable lithium-ion batteries that power on, fully discharge the battery before beginning repair. To expedite the battery discharge process:
 - Disconnect the charger from the device.
 - Increase display brightness to the highest level.
 - Turn on wi-fi and Bluetooth.
 - Open the Camera app in Windows.
 - Play music or video files from a local drive or streaming service.

Operate the device in this mode until the battery is fully discharged and the device powers off.

 **WARNING:** For Surface devices where the battery is affixed to the back cover, place the back cover with the battery in a location where it will be protected from possible punctures, impacts, crushing, or drops during the repair process. Refer to the [Battery Safety](#) section in this guide for more information.

- Ensure your work surface is level/flat and covered with ESD-safe, soft, non-marring material.
- We recommend wearing protective eyewear as a safety precaution when disassembling/re-assembling a device.
- Clean your work surface regularly to remove debris and abrasive particles.
- Review and follow the general guidelines and ESD compliance steps in this Guide prior to beginning work. Refer to the [Prior to Device Disassembly](#) section in this Guide for more information.
- Before opening a device, always wear an anti-static wrist strap and confirm your work area is properly grounded to protect vulnerable electronics from electrostatic discharge (ESD).
- Parts removed from a device during the repair process should be stored in ESD-safe bags and packaged for return or recycling in the same packaging that the new replacement part came in.
- If battery damage (e.g., leaking, expansion, folds or other) is discovered during device repair or if the battery is impacted or damaged during replacement, DO NOT proceed. Refer to the ASP Guidebook or contact Microsoft directly for proper device disposition.
- As you remove each subassembly from the device, place the subassembly (and all accompanying screws) away from the work area to prevent damage to the device or to the subassembly.
- During all activities (excluding feet-only replacement) check to ensure that no loose articles are on the back cover or remain inside the device before reassembling it.

 **IMPORTANT:** Remove rSSD (removable Solid-State Drive) whenever C-cover is removed from device. rSSD removal disconnects the battery from all device logical components for safety purposes. Refer to [Procedure-Removal \(rSSD\)](#) section for details.

 **IMPORTANT:** Whenever the rSSD has been removed, powering on the device requires that the rSSD and C-cover are installed. Refer to [Procedure - Installation \(rSSD\)](#) section for details.

- Review the [General Safety Precautions](#) and [Battery Safety](#) Sections of this Guide before beginning work. Refer to the “[Prior to Device Disassembly](#)” section of the Guide for additional details.
- Check to make sure that general guidelines and ESD compliance steps are followed prior to starting activities. Refer to [Prior to Device Disassembly](#) section on ([page 14](#)) for details.



- Device Serial Number Notation – The Surface device serial number for this model is located on the bottom of the chassis. When the chassis is replaced during service/repair, the device serial number becomes physically disconnected from the customer’s device. To ensure the customer has the best experience if any future Microsoft support is required, it is recommended to create a notation of the device serial number and provide it to the customer upon completion of the repair.

Battery Safety

- This device contains a built-in, lithium-ion rechargeable battery. Battery safety is a significant concern when repairing a device.
- For optimum compatibility, performance, and product safety, we recommend using genuine Microsoft replacement parts. Use of non-Microsoft (non-genuine), incompatible, reused, or modified batteries; improper battery installation; improper handling or storage of batteries; and/or failure to follow the instructions in this Guide could cause battery overheating, expansion, venting, leaking, or a thermal event which could result in fire, serious personal injury, death, data loss, or damage to the device or other property damage.
- Before beginning device repair, ensure your workspace is free of flammable debris or materials, has adequate ventilation, and that you have a fire suppressant device (example: fire blanket, container of sand, Class B fire extinguisher) within easy reach or you are within 20 feet of a fireproof enclosure. Fireproof enclosures should be kept free of combustible or flammable materials.
- Use personal protective equipment (PPE) when handling damaged, venting, or hot battery packs.
- Use the following best practices when handling batteries:
 - Always fully discharge batteries by running an application such as video playback with the device unplugged. If the device does not function while unplugged, you may leave out this step.
 - Do not puncture, impact, strike, bend, or crush the battery or a device containing a battery.
 - Keep your workspace clear of debris, extra tools, and sharp objects.
 - Exercise caution when using sharp tools near the battery to avoid impacting or poking the battery.
 - Don’t leave loose screws or small parts inside the device.
 - Avoid using tools that conduct electricity.
 - Do not drop or throw a lithium-ion battery.
 - Do not expose the battery to excessive heat, sunlight, or temperatures outside the battery’s normal operating range (0°C to 60°C)/(32°F to 140°F).
 - Ensure you handle, recycle, and/or dispose of used or damaged batteries in accordance with local laws and regulations. Follow Handling Used, Damaged or Defective Li-ion Batteries below.
- If device repair cannot be completed immediately and the device needs to be stored temporarily before restarting the repair:
 - Select a storage location and process that follows the battery safety precautions in this Guide.
 - Avoid exposing the device to environmental conditions and objects that could damage the battery pack.
 - Reinspect the battery pack as outlined in this Guide prior to restarting repair and installing the new battery pack.



Lithium-Ion Battery Inspection

Upon device opening, we recommend that you visually inspect the battery for signs of damage. Factors to consider when inspecting the battery include, but are not limited to:

- Evidence of leaking or venting
- Visible signs of physical or mechanical damage, such as:
 - Expansion or swelling. In expanded or swollen batteries, the soft pouch encasing the cell pulls away from the inner material and appears baggy, loose, or puffy.
 - Discoloration of the battery casing.
 - Odor, smell, or visible corrosion. Leaked battery electrolyte smells like nail polish remover (acetone).
 - Dents along the battery cell edges or on the top surface.
 - Surface scratches that have exposed the aluminum beneath the black coating layer on the battery.
 - Loose or damaged wires.
 - Known misuse or abuse.

Any battery exhibiting the signs listed above must be replaced. Consult the Battery Replacement section of this document for battery replacement instructions.

Handling Used, Damaged, or Defective Lithium-Ion Batteries:

- DO NOT dispose of used lithium-ion batteries, whether damaged or not, in household or commercial garbage or recycling bins.

⚠ WARNING: DO NOT SHIP DAMAGED OR DEFECTIVE BATTERIES ALONE OR INSIDE DEVICES. Damaged or defective batteries and devices containing damaged or defective batteries require special packaging and handling. Prior to transport:

- Follow all instructions provided by your local e-waste recycling or household hazardous waste collection provider.
 - Place the device or battery in an individual, non-metallic inner packaging, such as a zip-to-close plastic bag, that completely encloses the device or battery.
 - Surround the inner packaging with non-combustible, electrically non-conductive, absorbent cushioning material.
 - Each damaged battery or device containing a damaged battery should be packed individually in its own carton and that carton should be clearly marked as containing a damaged battery.
-

For more information on industry practices concerning damaged, defective, or recalled batteries, please see [PHMSA Lithium-Battery-Recycling-Safety-Advisory](#).

Undamaged, used lithium batteries can be sent to e-waste recycling or household hazardous waste collection points for processing. Please see <https://www.microsoft.com/en-us/legal/compliance/recycling> for more information.



Report Battery Thermal Events to Microsoft

A thermal event is a rapid chemical chain reaction that can occur inside a battery cell. During a thermal event, the energy stored inside the battery is released suddenly, resulting in heating and/or smoke and, in some instances, fire or flame. A battery thermal event can be triggered by physical damage to the battery (including during replacement/repair), improper storage, or exposure to temperatures outside of the battery's operating range.

Act immediately if you see any of the following symptoms of a battery thermal event:

- Smoke, soot, sparks, or flame emitted by the battery or from a device containing a battery.
- The battery pouch suddenly expands in size.
- A popping or hissing noise from the battery or a device containing a battery.

Actions to take:

- **DO NOT use water. Immediately smother** the battery or device with clean, dry sand, a fire blanket, or an appropriate (Class B) fire extinguisher. If using sand, dump the sand all at once until the device is completely covered.
- **Contact** local fire authorities if further assistance is needed.
- **Exit** the work area and ventilate it until it is clear of smoke.
- **Wait** at least 2 hours before attempting to touch the device.
- **Dispose** of the damaged battery or device in accordance with local environmental or e-waste laws and guidelines.

 **WARNING:** DO NOT SHIP DAMAGED OR DEFECTIVE BATTERIES ALONE OR INSIDE DEVICES. Damaged batteries and devices containing damaged batteries require special packaging and handling. See [Handling Used, Damaged, or Defective Lithium-Ion Batteries](#) in this Guide for additional information.

Stop Repair and Contact Microsoft

If any Microsoft device visually exhibits any of the following symptoms, cease all further repair efforts and contact Microsoft Surface Customer Support to report and obtain next steps:

- Any burned or melted components, traces, or plastic parts on the outside of the device, or which otherwise exhibits heat damage, including charring seen in charging and other ports.
- Any burned or melted components, traces, or plastic parts on the inside of the device, or which otherwise exhibits heat damage.
- Any accessories exhibiting melting or heat damage that are included with the Microsoft device, such as power supplies, keyboards, mice, cables, charging connectors, etc.
- Any devices that exhibit a case that has separated apart or opened for reasons other than impact damage from dropping, evidence of tampering, or separation caused by a malfunctioning battery.
- Any other finding that may constitute a safety hazard to the user, such as sharp edges on plastics. Microsoft Surface Customer Support will ask you to provide the following information:
 - The model and serial number of the affected Microsoft Surface device and/or accessory(ies).
 - A brief description of the damage found.
 - Clear photographs depicting the symptoms observed.



Illustrated Service Parts List

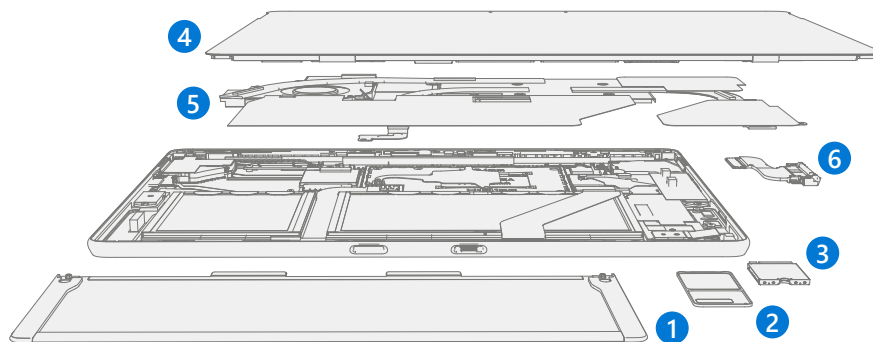

IMPORTANT: Device service part availability is segmented into two groups. FRUs are parts available for repair activity through an Authorized Service Provider under specific contract with Microsoft. CRUs/Spares are parts available for repair activity by a skilled technician.

Item	Component	FRU/ASP Part No.	CRU Part No.	Models	
				WiFi 1983	LTE 1982
(1) Kickstand					
	Graphite Kickstand	DHI-00002	I61-00002	X	
	Platinum Kickstand	DHI-00001	I61-00001	X	
	Platinum Kickstand	DHI-00003	I61-00003		X
(2) SSD Door					
	Graphite SSD Door	DCB-00002	DCI-00002	X	
	Platinum SSD Door	DCB-00001	DCI-00001	X	X
(3) Removable Solid-State Drive (NOTE: rSSD size must be same as original)					
	rSSD 128GB	DDB-00001	DFB-00001	X	X
	rSSD 256GB	DDI-00001	DFI-00001	X	X
	rSSD 512GB	DEB-00001	DGB-00001	X	X
	rSSD 1TB	DEI-00001	DGI-00001	X	
(4) TDM					
	ProX TDM WW	DHB-00001	I62-00001	X	X
(5) THM					
	THM WiFi	DBZ-00001		X	
	THM LTE	DC8-00001			X
(6) Surflink					
	Surflink WW	DBY-00001		X	X



Service Diagnostics/Troubleshooting Overview

- For general Surface support, visit www.support.microsoft.com
- To troubleshoot device feature/function problems or learn more about Surface Pro 8, visit www.aka.ms/SurfaceProHelp
- If you'd like to learn more about Windows, visit www.aka.ms/WindowsHelp
- To learn more about the accessibility features of the Surface Pro 8 to the online user guide at www.aka.ms/Windows-Accessibility

Software Tools:

- How To: [Update Surface device firmware and OS](#)
- How To: [Surface Tools Video](#)
- Download: [Surface drivers and firmware](#)
- Download: [Surface Diagnostic Toolkit \(SDT\)](#)
- Download: [Surface Data Eraser](#)
- Download: [Surface Imaging Tools](#)

rSSD Troubleshooting Approach:

The following approach should be considered when troubleshooting Surface devices:

1. Update device to latest OS/FW versions using the SDT tool.

 **IMPORTANT:** Device updates are required as a prerequisite to all hardware replacement.

2. Verify any suspected hardware failures by setting the device in a known OS/FW version state and running SDT to verify fault:
 - a. Replace the device's internal rSSD with a BMR imaged rSSD containing latest OS and FW updates (not supplied – must be created as a fault verification jig/tool) – Refer to Software Tools section above for details on imaging.
 - b. Run SDT and verify if condition persists or if resolved with use of BMR imaged drive – Refer to Software Tools section above for details on SDT.
 - i. If problem is resolved, then re-image original rSSD or replace original rSSD and image.



Component Removal and Replacement Procedures

Prior to Device Disassembly

- Read this Guide in its entirety before starting any repairs. Pay special attention to the [Repair-Specific Precautions and Warnings](#) and the [Battery Safety](#) sections of the Guide.

Battery Warning

 **WARNING:** Please note that the battery bears the following warning label. Please heed the information provided on the label.



Battery is replaceable by trained personnel; replacement must follow Microsoft procedure
See <http://aka.ms/surface-safety> for important information.

- Risk of fire or burning – contact Microsoft for assistance
- Do not modify battery, its wiring, or connectors
- Do not short circuit, bend, dent, crush, or puncture battery
- Do not dispose of battery in fire or expose to high temperatures (+140°F/60°C)



rSSD Replacement Process

Preliminary Requirements

 **IMPORTANT:** Be sure to follow all special (bolded) notes of caution within each process section.

Required Tools and Components

- **Tools:**
 - 3IP (Torx-Plus) driver
 - Anti-static wrist strap (1M Ohm resistance)
 - Soft ESD safe mat
 - Microfiber / Lint free cloth
 - SIM eject tool (or equivalent 0.023 in / 0.58 mm diameter paperclip)
- **Components:**
 - rSSD (Refer to [Illustrated Service Parts List](#))

Prerequisite Steps:

- **Power off device** – Ensure device is powered off and disconnected from a power supply.
- **General Safety** – Check to make sure that general guidelines and ESD compliance steps are followed prior to opening device. Refer to Prior to Device Disassembly section ([page 14](#)) for details.

Procedure – Removal (rSSD)

1. **Remove rSSD door** – Use SIM ejector tool.

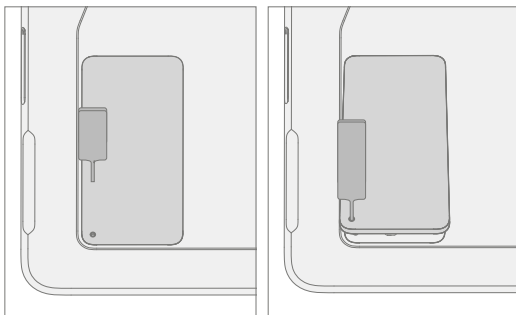

2. **Remove rSSD screw** – Use a 3IP (Torx-Plus) driver to remove the screw securing the rSSD.

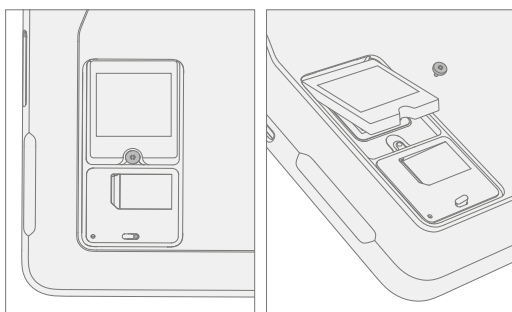

3. **Remove rSSD** – The rSSD should lift upwards to ~15-degree tilt after screw is removed. Carefully grab sides of rSSD case and pull out of main board socket at same ~15-degree angle.

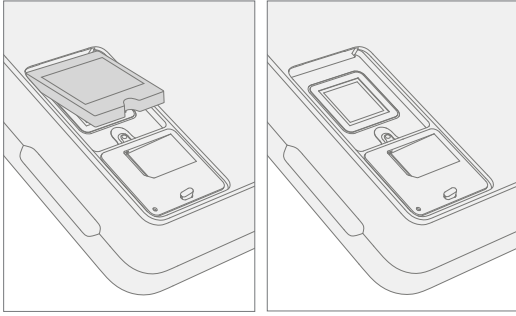

Procedure – Installation (rSSD)

 **IMPORTANT:** Only a Microsoft rSSD of like capacity should be replaced in the device.

1. **Insert rSSD** – Insert the connector end of the rSSD into the rSSD connector on Main board at ~15-degree angle.

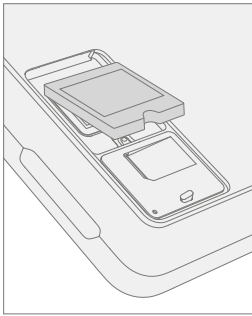

2. **Install new rSSD screw** – Use a 3IP (Torx-Plus) driver to install a new rSSD screw until the screw is just snug and seated, and then turn another 45 degrees (1/8 turn) or until screw is fully fastened.

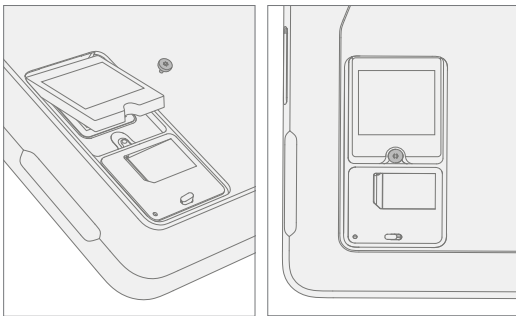

3. **Replace rSSD door.**

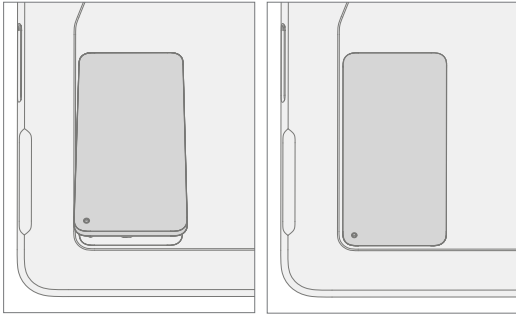

4. **Imaging** – Image the new rSSD by using a BMR Imaging USB drive specific to the device model.

 **IMPORTANT:** Refer to Surface imaging process – [Surface Imaging Tools](#)

5. **Run SDT** – Run SDT to ensure all device features and functions operate as expected.



Swap rSSD to a new device process

Preliminary Requirements

-
-  **IMPORTANT:** Be sure to follow all special (bolded) notes, cautions, & warnings in each process section. The rSSD 3IP screw will be reused in this process. Only a Microsoft rSSD of like capacity should be replaced in the device.
-

Required Tools and Components

- **Tools:**
 - 3IP (Torx-Plus) driver
 - Anti-static wrist strap (1M Ohm resistance)
 - Soft ESD safe mat
 - Microfiber / Lint free cloth
 - SIM eject tool (or equivalent 0.023 in / 0.58 mm diameter paperclip)
 - USB Drive
 - Surface Dock
 - Wired Ethernet connection to the Internet
 - USB keyboard
- **Components:**
 - New SIM/rSSD door if required. (Refer to [Illustrated Service Parts List](#))

Prerequisite Steps:

- **Using an Internet connection install all available updates:** Navigate to **Settings-> Update and Security** and check for Windows Update.
- Consumer using Windows Home:
 - The Bitlocker recovery key is automatically generated for users with an MSA and can be found by the user by searching the web for "bitlocker recovery key" and logging into their MSA. If the user does not have an MSA based account, the disk will not be encrypted.
- Commercial using Windows Pro:
 - This is managed via commercial policy, and each business may have their own bitlocker policy / recovery method.
 - Confirm that the customer knows the **Windows password to the device.**
- **General Safety** – Check to make sure that general guidelines and ESD compliance steps are followed prior to opening device. Refer to Prior to Device Disassembly section ([page 14](#)) for details.



Procedure – Swap (rSSD)

1. **Manage Bitlocker**
 - a. If rSSD remains encrypted during swap
 - i. Navigate to **Bitlocker > Manage Bitlocker > Generate Bitlocker Recovery Key.**
 - ii. Plug in USB drive.
 - iii. Save the recovery key to USB storage.
 - iv. Remove the USB drive.
 - b. If rSSD can be unencrypted before swap
 - i. Navigate to **Bitlocker > Manage Bitlocker.**
 - ii. Select **Turn Off Bitlocker.**
2. **Shut down customer's old device and remove SIM/rSSD door on new device** – Use SIM ejector tool.

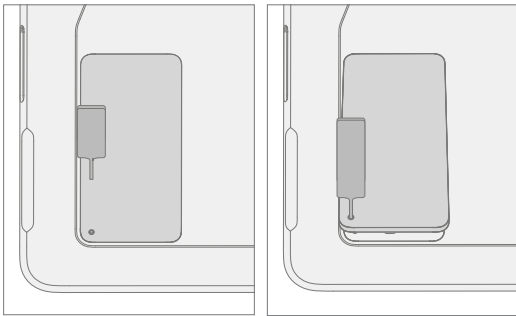

3. **Remove SIM (if present in customer's old device)** – Push edge of SIM card to release from device.

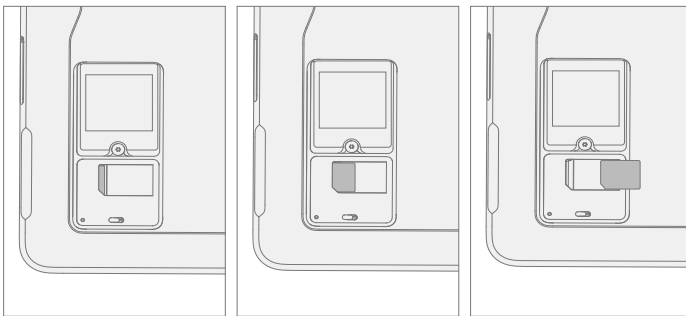

4. **Remove rSSD screw from both devices** – Use a 3IP (Torx-Plus) driver to remove the screw securing the rSSD. Take care not to damage the screw; it will be reused.

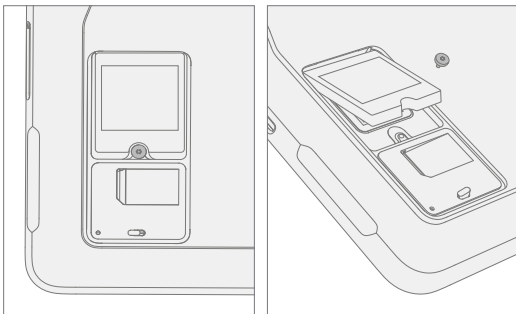

5. **Remove rSSD from both devices** – The rSSD should lift upwards to ~15-degree tilt after screw is removed. Carefully grab sides of rSSD case and pull out of main board socket at same ~15-degree angle.

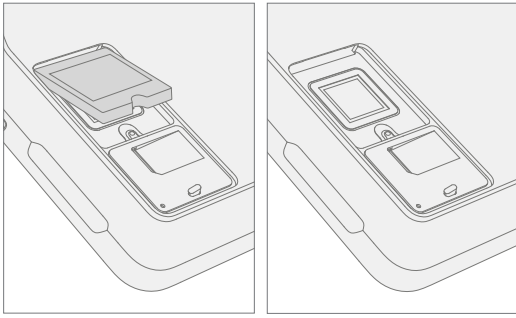

6. **rSSD Swap** – Insert rSSD removed from the new device into customer's original device, then insert customer's original rSSD into new device. Insert the connector end of the rSSD into the rSSD connector on Main board at ~15-degree angle.

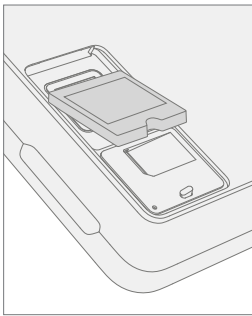

7. **Install rSSD screws in both devices** – Use a 3IP (Torx-Plus) driver to install the rSSD screw until it is just snug and seated, and then turn another 45 degrees (1/8 turn) or until screw is fully fastened.

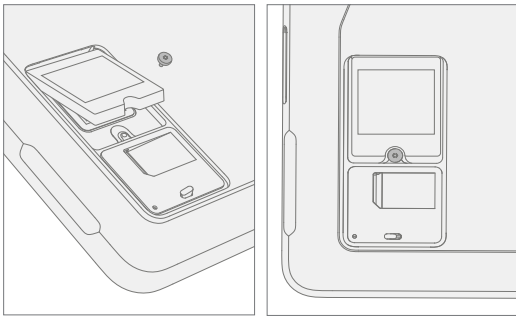

8. **Install SIM (if present from the customer’s old device in the new device).**

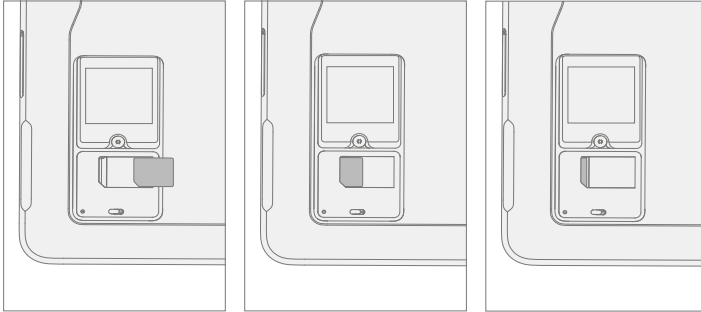

9. **Replace SIM/rSSD door on both devices.**

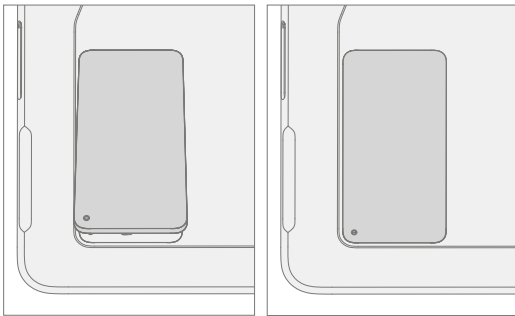

10. **Plug new device into power and wired Internet connection.**

11. **Power on new device.** The device may go through a firmware update during startup.

12. **If the SSD remained encrypted during the swap:**

- a. Plug in USB drive with Bitlocker recovery key.
- b. Open the .txt file with the Bitlocker recovery key.
- c. Manually enter the recovery key into the new device.

13. **Connect a keyboard to the new device.**

14. **Navigate to Sign-In Options->Password (key icon on the left side).**

15. **Customer enters Windows password. Select “Sign In”.**

16. **Customer may need to go through two-factor authentication.**

17. **Once fully signed in, navigate to Start->Account->Sign Out.**



18. **Customer signs in with Windows password again.**
19. **Customer prompted to setup Windows Hello and PIN.**
 - a. If the device was previously Bitlocked, navigate to **Bitlocker > Manage Bitlocker > Resume Bitlocker.**
20. **Run SDT** – Run SDT to ensure all device features and functions operate as expected.
21. **Check Windows activation** – Navigate to **Settings > Activation.** If there is any error message, select **Troubleshoot.**
22. **Check Office Account** – Open Office app and then navigate to **File > Account** and check for any error messages.
23. **Check cellular (if SIM present)** – Unplug device from wired network and disable WiFi. Check that cellular network shows connected, and that the device can open a webpage.
24. **Return customer's original device per established procedures.**



Kickstand Replacement Process

Preliminary Requirements

 **IMPORTANT:** Be sure to follow all special (bolded) notes of caution within each process section.

Required Tools and Components

- **Tools:**
 - 3IP (Torx-Plus) driver
 - Loctite SF 7649
 - Loctite 243
 - Soft ESD safe mat
 - Microfiber cloth
- **Components:**
 - Kickstand (Refer to [Illustrated Service Parts List](#))

Prerequisite Steps:

- **Power off device** – Ensure device is powered off and disconnected from a power supply.
- **General Safety** – Check to make sure that general guidelines and ESD compliance steps are followed prior to opening device. Refer to Prior to Device Disassembly section ([page 14](#)) for details.

Procedure – Removal (Kickstand)

1. **Place device screen-down on soft ESD-safe mat.** Ensure mat is clear of any abrasive material that may scratch the Touch Display Module (TDM) glass.
2. **Extend the kickstand to approximately 90 degrees.**

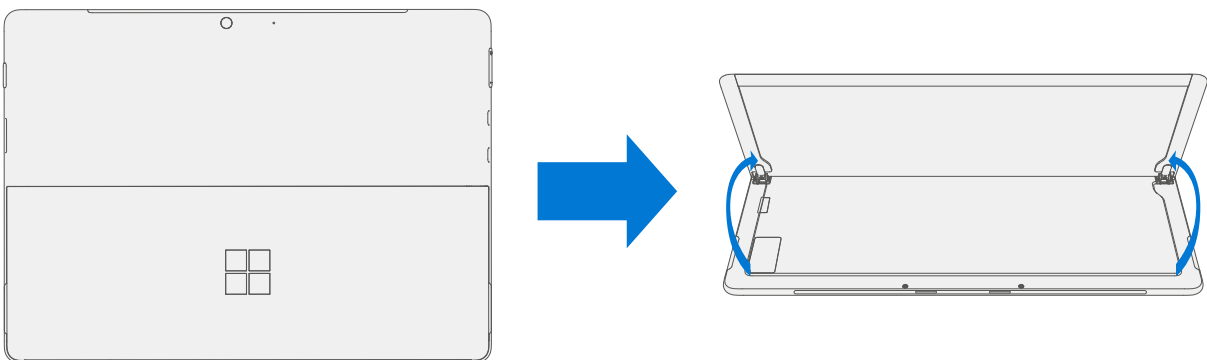

3. **Remove hinge screws** – Use your finger to hold the back of the kickstand behind the hinge while removing the hinge screws. One screw for each hinge. Ensure screws do not fall into the hinge opening.

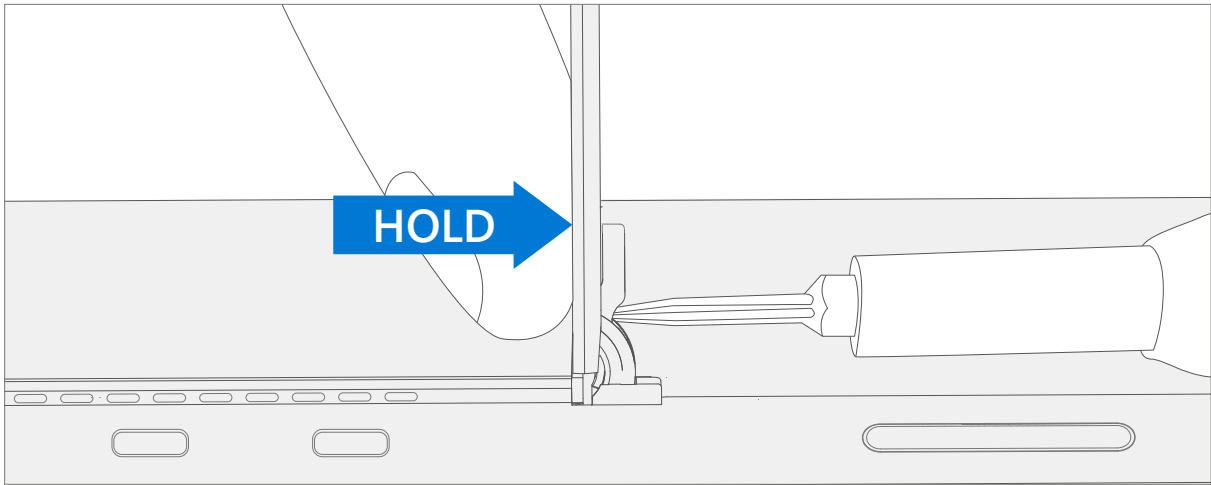

4. **Angle Kickstand Down** – Firmly grip the hinges and the kickstand between thumb and index fingers. Rotate the kickstand from 90 degrees to approximately 45 degrees.



5. **Release Kickstand Threaded Bosses** – Using fingers on the underside of the kickstand and thumb on the topside, slightly rotate the kickstand about the axis as shown below. The kickstand should rotate ~5 degrees to free the two threaded bosses of the kickstand from the recesses of the hinges.

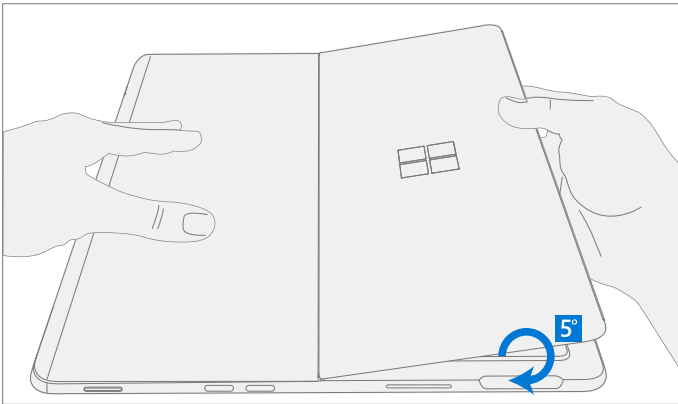

6. **Remove Kickstand** – Using the palm of your hand, firmly hold the device down from the center of the IBC. Simultaneously, grip the kickstand off-center between your thumb and index finger and firmly pull. Pull with a moderate amount of force until the foam inserts slide out of the device. If the kickstand is stuck, ensure the threaded bosses has not slipped back into the recess on the hinges.

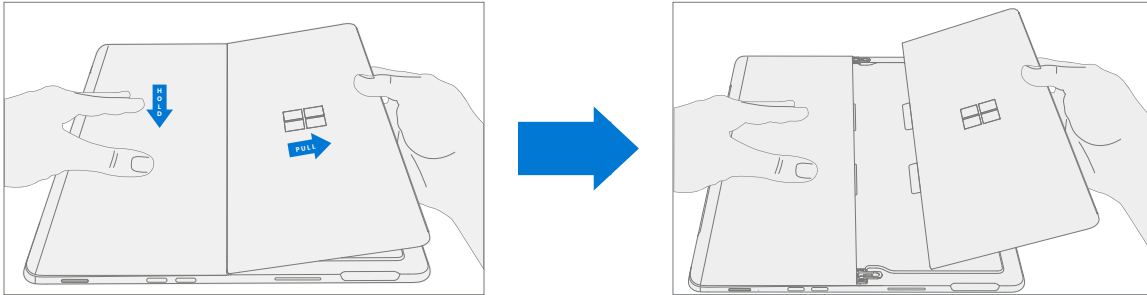

⚠ WARNING: Inspect Removed Kickstand Foam Tabs – Damaged foam or tabs cannot be safely removed. Attempts to do so can damage internal components. Do not insert anything other than the tabs into the slots. Ensure both tabs are complete and show no signs of tearing. If tabs show signs of tearing, part of the foam may still be inside the device. Before proceeding, all foam must be removed from the device. Foam left inside will require whole unit exchange.

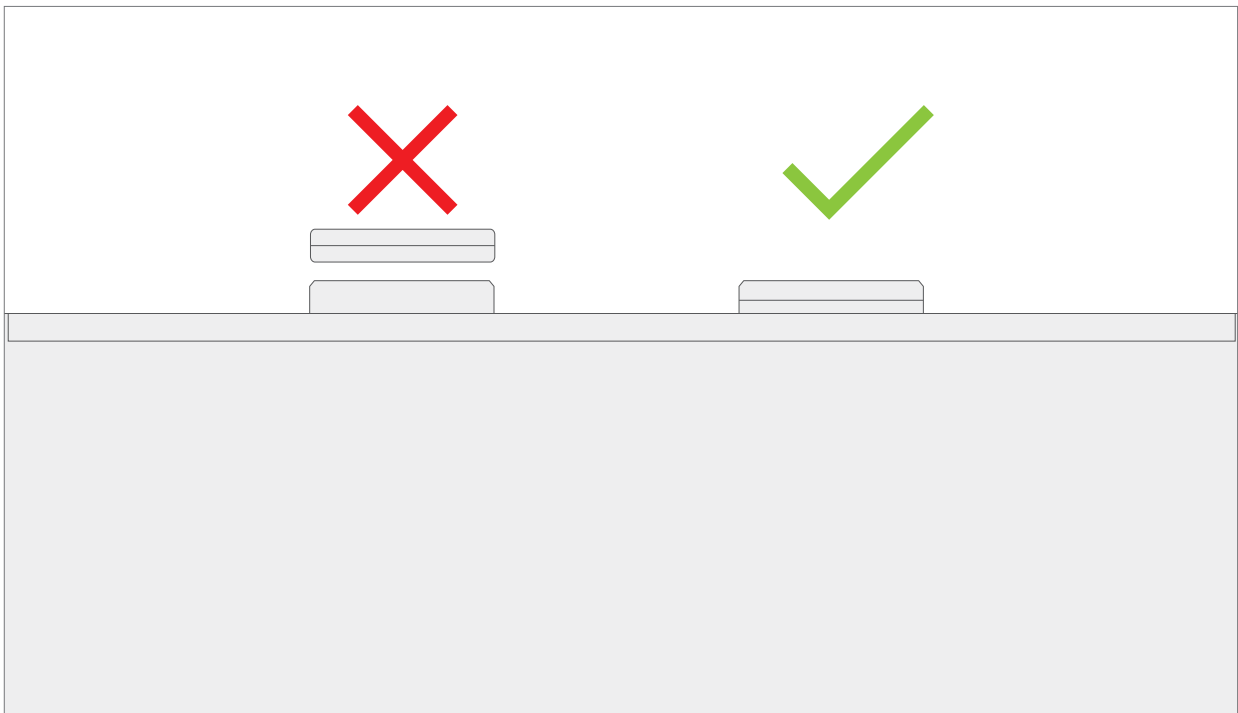

Procedure – Installation (Kickstand)

 **IMPORTANT:** Use caution when handling new kickstand assembly to avoid cosmetic damage of the kickstand and the device.

1. **Insert Foam Tabs** – With the hinges still at ~45 degrees start to slide the new kickstand's foam tabs into the slots on the back of the IBC. Foam should slide in with minimal force—do not crumple the foam by using excess force. Do not slide the foams completely into the device—insert the foam tabs until ~3/4 of the foam tabs are inside the device.

 **CAUTION:** Do not use any tool or sharp object to assist inserting the tabs into the slots. Only the tabs should be inserted. Doing so could damage internal components.

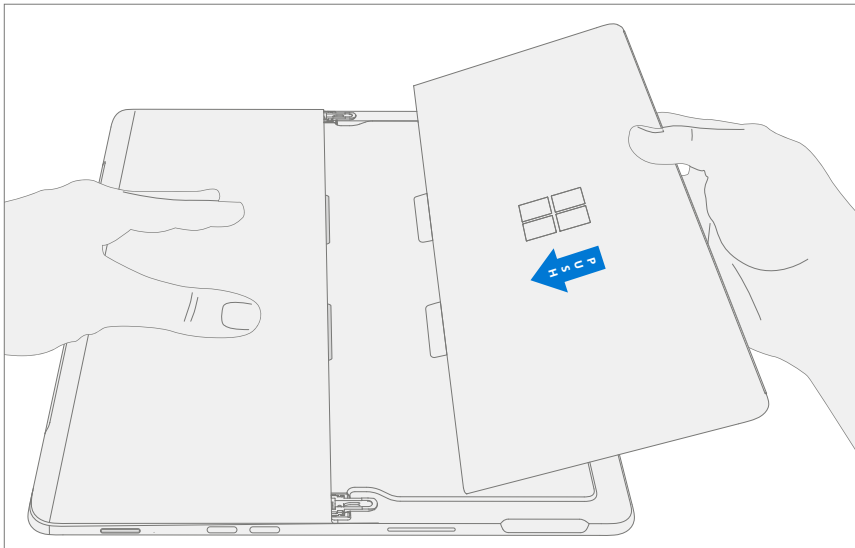

2. **Slot Outer Lip of Hinge into Kickstand** – Using fingers on the underside of the kickstand and thumb on the topside, slightly rotate the kickstand about the axis as shown below. The kickstand should rotate ~5 degrees to catch the outer lip of the hinge. Push the kickstand toward the device.

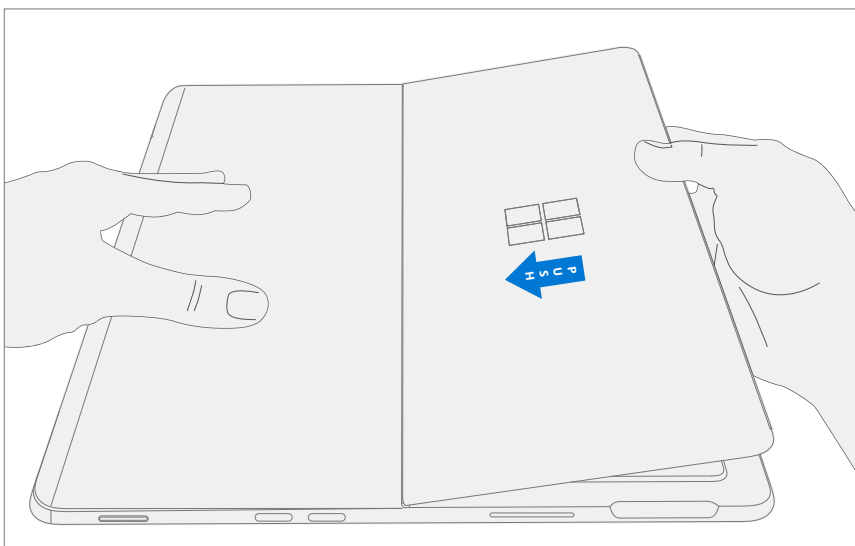

3. **Slip Kickstand Threaded Bosses into Hinge Recesses** – Maintaining pressure on the kickstand to prevent it from backing out, rotate the kickstand down into place (Figure 7-9). The threaded bosses of the kickstand should slip into the recesses of the hinges.

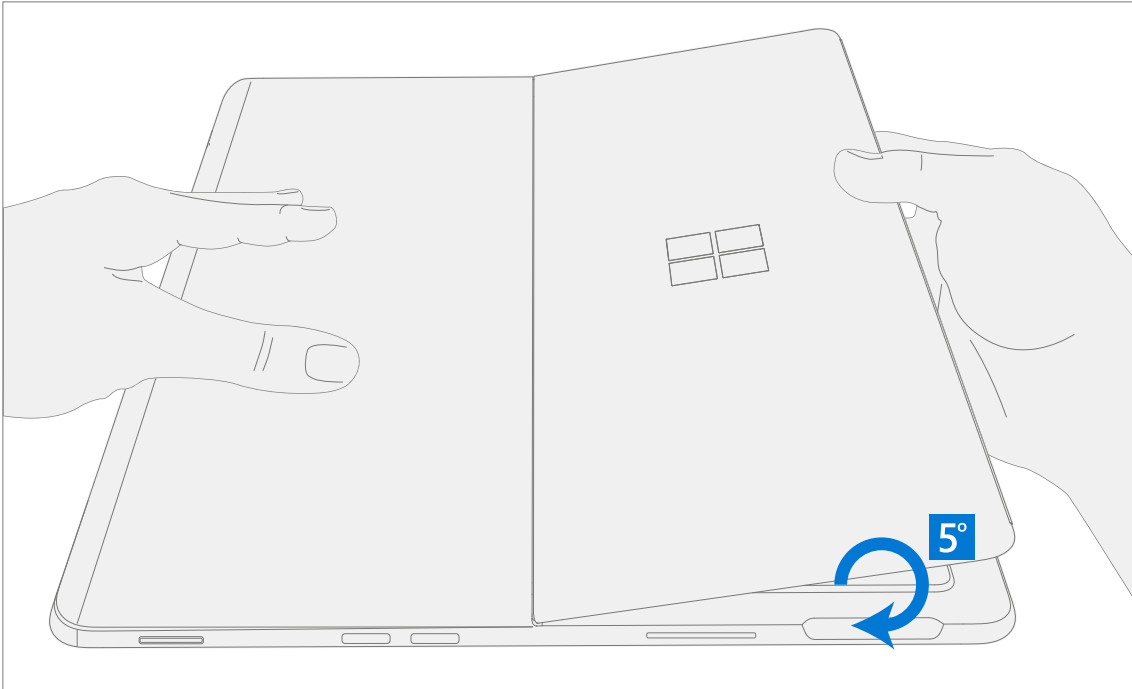

4. **Rotate the Kickstand Up** – Firmly grip the hinges and the kickstand between thumb and index fingers as shown below. Rotate the kickstand from 45 degrees to approximately 90 degrees.

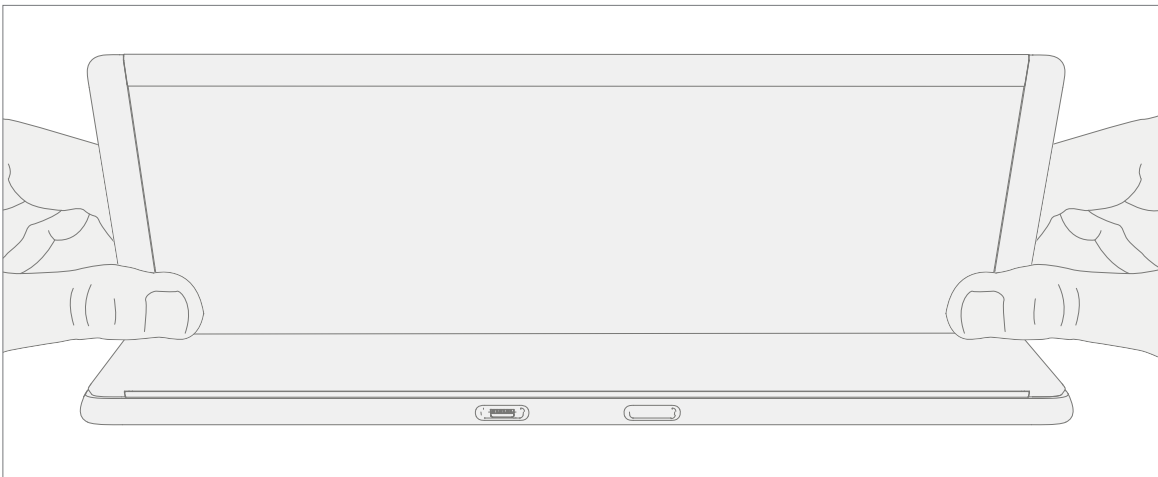

5. **Apply thread locker to screws** – Brush new screws with Loctite SF 7649 Activator. Let screws sit for 2 minutes after activator is applied before assembling to device.

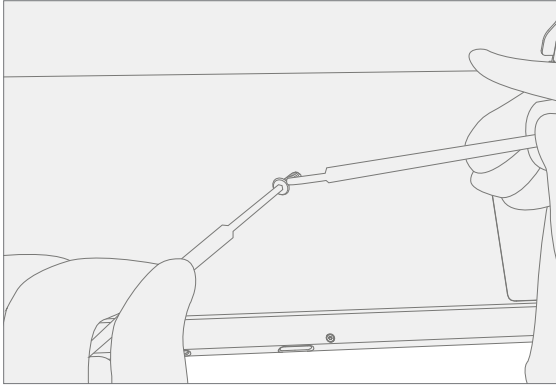

6. **Apply thread locker to screws bosses** – Apply one drop of Loctite 243 thread locker to each screw boss.

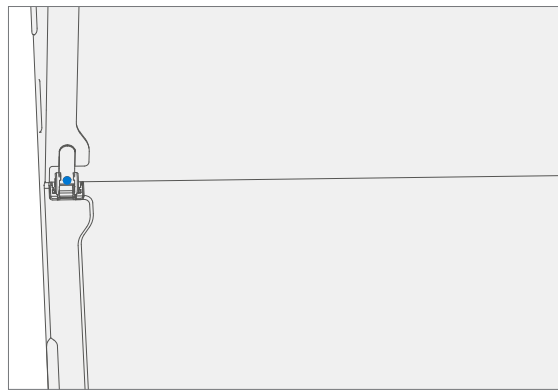
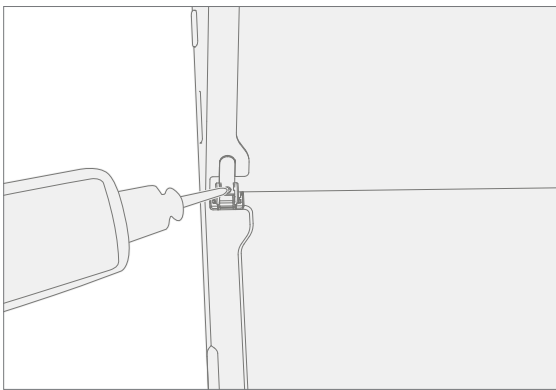

7. **Install hinge screws** – Use your finger to hold the back of the kickstand behind the hinge while installing the screws until they are fully seated. Ensure the kickstand is properly aligned and seated in the hinges, then tighten the screws an additional ~quarter turn (~90 degrees). Be careful to tighten the screws only until snug and not to strip the kickstand threads. Ensure screws do not fall into hinge opening.

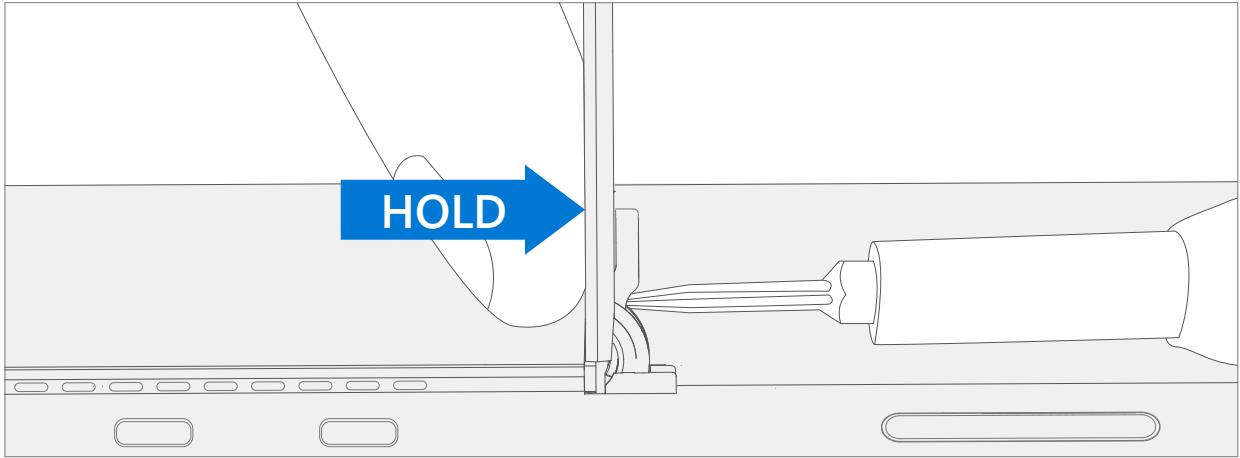

8. **Final inspection Kickstand installation** – Fold the kickstand down and peel off protective plastic from the kickstand and logo if present. Verify the side edges of the kickstand are aligned with the midframe walls and that there are no obvious steps/gaps between the kickstand and the IBC. Wipe the device thoroughly (including under the kickstand) with the microfiber cloth to remove all fingerprints.



TDM Replacement Process

Preliminary Requirements

-
-  **IMPORTANT:** Be sure to follow all special (bolded) notes of caution within each process section.
-

Required Tools and Components

- **Tools:**
 - 3IP (Torx-Plus) driver
 - Anti-static wrist strap (1M Ohm resistance)
 - Soft ESD safe mat
 - Microfiber / lint free cloth
 - SIM eject tool (or equivalent 0.023 in / 0.58 mm diameter paperclip)
 - Isopropyl alcohol dispenser bottle (use 91% or greater IPA)
 - Cotton swab
 - USB drive with Surface Diagnostic Toolkit
 - Spudger
 - iFixit opening tool
 - Plastic opening pick
 - Two 2 in spring clamps
 - TDM PSA debonding tool (M1214770-001)
 - TDM PSA bonding frame (M1178722-001)
 - Foam Pad
(Material: EVA Foam, Thickness: 9.5 mm, Density: 0.03 g/cm³, Minimum 229 mm x 305 mm)
(Recommended McMaster PN: [86095K43](#))
 - TDM bonding weights 23 kg (Recommended using two Ruck weights one 9 kg, one 14 kg) (Alternate using steel shot bags one 9 kg, one 14 kg)
- **Components:**
 - TDM (Refer to [Illustrated Service Parts List](#))



Prerequisite Steps:

- **Prep Device** – Device must be set in **TDM Replacement Mode** prior to removing a **faulty** TDM.
 - a. **Connect software tools USB drive** with SDT to USB connector on device under repair.
 - b. **Connect power supply** to device.
 - c. **Power on device** – Depress the power button on the side of the device.
 - d. **Run software tool** – At the device OS, use Windows Explorer, navigate to USB drive and run: **SDT** – Select Repair setup and validation. Run the Touch Display Setup. At the end of the tool process device will power down.

! **IMPORTANT:** This step must be carried out on the device successfully **before** removal of a **faulty** TDM. Ensure light levels in the work area remain consistent during the touch display setup process.

- **Power off device** – Ensure device is powered off and disconnected from a power supply. Remove all attached cables and drives.
- **General Safety** – Check to make sure that general guidelines and ESD compliance steps are followed prior to opening device. Refer to Prior to Device Disassembly section ([page 14](#)) for details.
- **Remove rSSD** – Remove the rSSD as detailed in the Procedure – Removal (rSSD) ([page 15](#))

Procedure – Removal (TDM)

1. **Speaker Mesh Preparation** – Place the device face up on a Soft ESD safe mat. Use an iFixit opening tool to widen the gap between the right speaker mesh and device. Push the sharp edge into the gap and side to side along the device edge. Once the flat tip fits fully in the gap, use it to push the speaker mesh towards the device, repeating uniformly along the length of the speaker mesh. The metal mesh will either fold lengthwise or slide completely under the glass. Repeat this process for left speaker mesh.

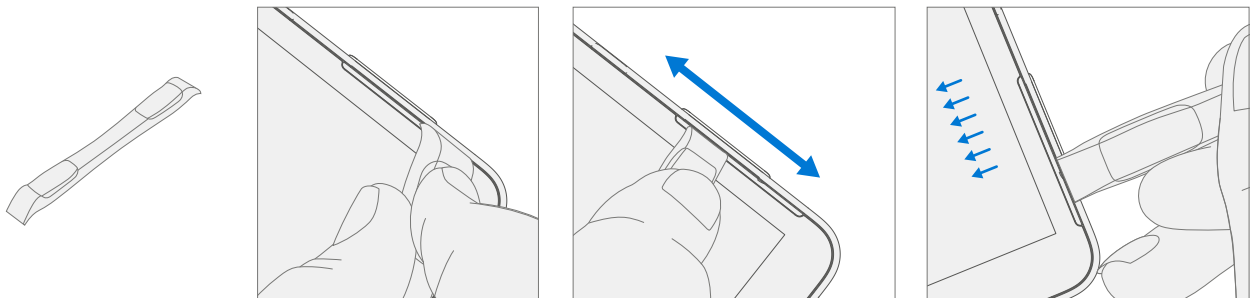

2. **Debonding TDM Marking Pick Depth** – Using a metric ruler draw a 2 mm mark and 8 mm mark on the plastic pick.

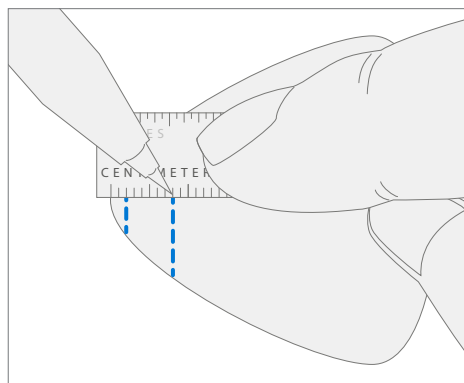

3. TDM Debonding Tool

- a. Install marked pick in the holder with the marks in view. Use a 3 mm Allen Driver to adjust pick height to the lowest setting.

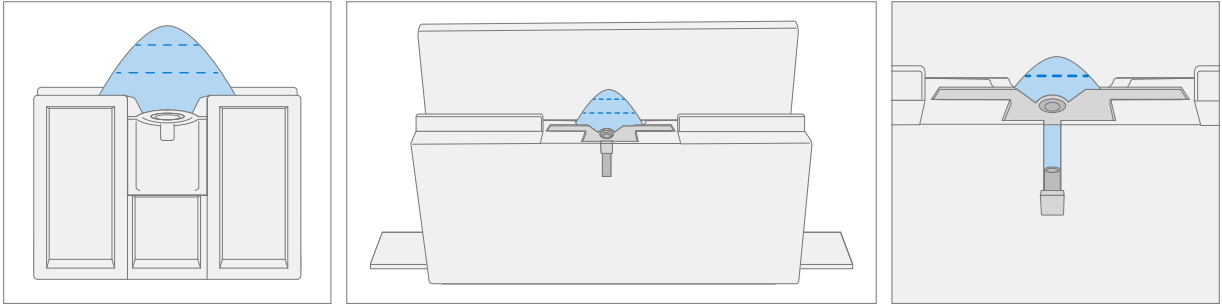

- b. Clamp debonding tool to edge of workbench. Ensure the cut depth adjustment can be accessed while the tool is clamped down.

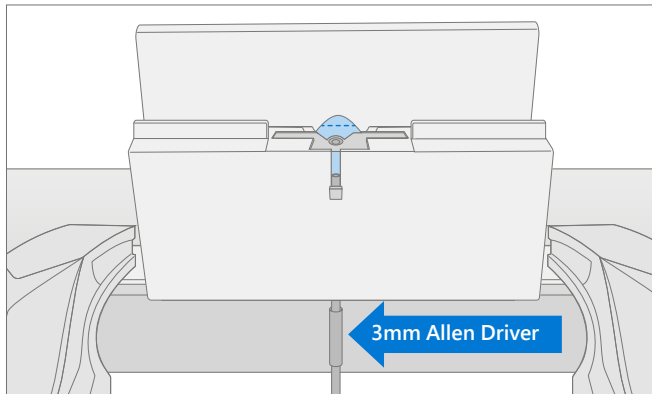

- c. Place the right side speaker edge of the device in the debonding tool above the pick. Adjust the pick height to the 2 mm mark. Ensure it enters the gap between the TDM and bucket edge.

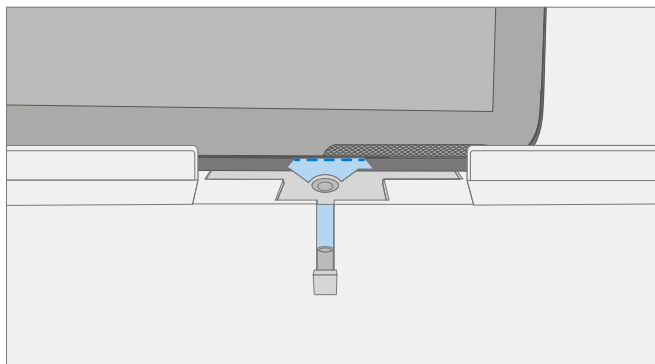

d. With both hands draw the right side of the device thru the debonding tool track.

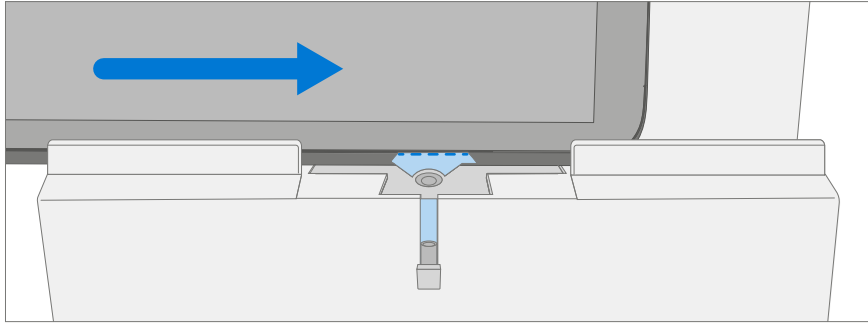

e. At the bottom right corner rotate the device in the debonding tool track. Draw the bottom side of the device thru the debonding tool track.

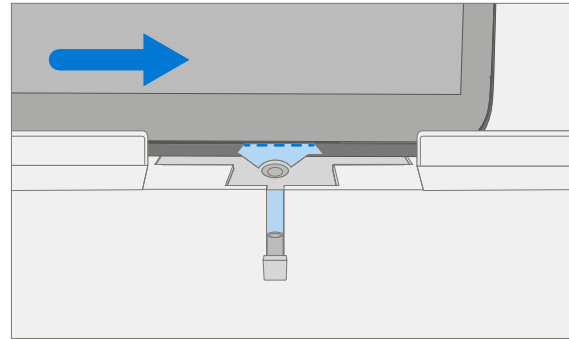
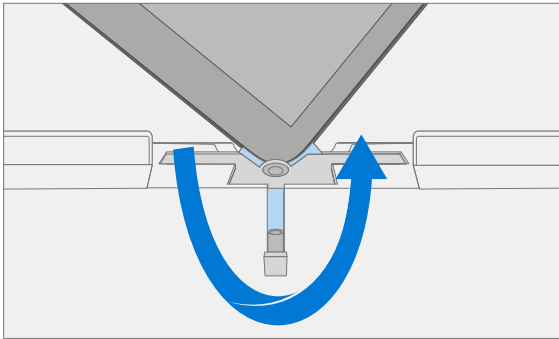

f. At the bottom left corner rotate the device in the debonding tool track. Draw the left side of the device thru the debonding tool track.

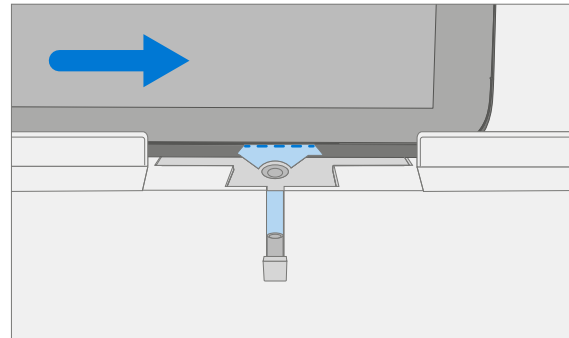
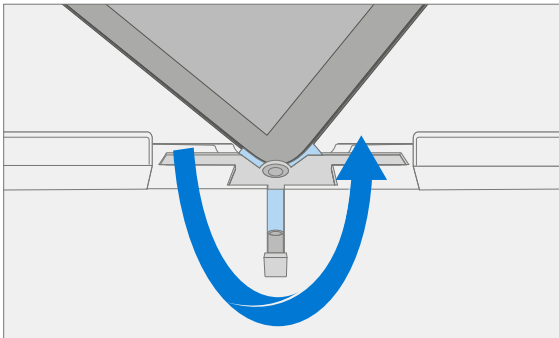

g. At the top left corner rotate the device in the debonding tool track. Draw the top side of the device thru the debonding tool track.

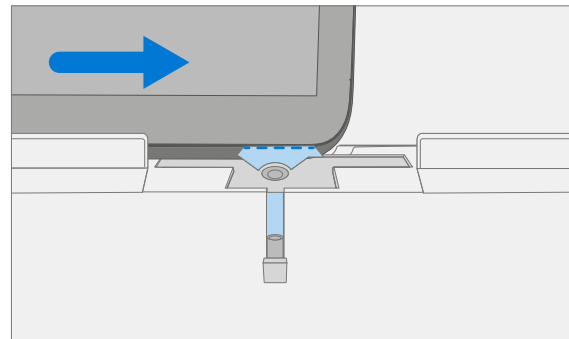
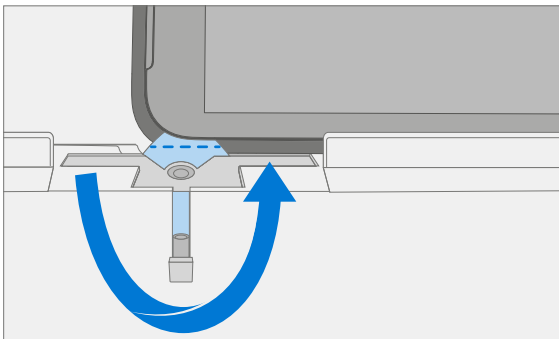

- h. Place the top left edge of the device in the debonding tool track. Adjust the pick height to the 8 mm mark. Ensure it enters the gap between the TDM and bucket edge. With both hands draw the top edge of the device thru the debonding tool track.

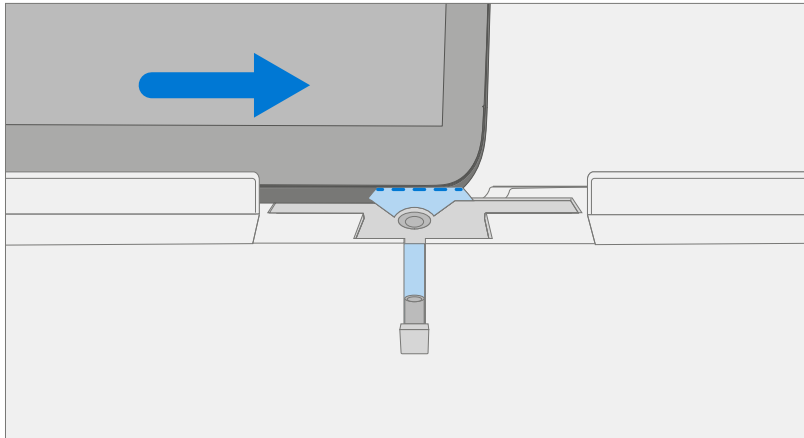

- ! **CAUTION:** Do not insert the pick more than 2 mm along the left and right sides or bottom edge of the TDM. The pick depth should not exceed 8 mm along the top edge of the TDM.

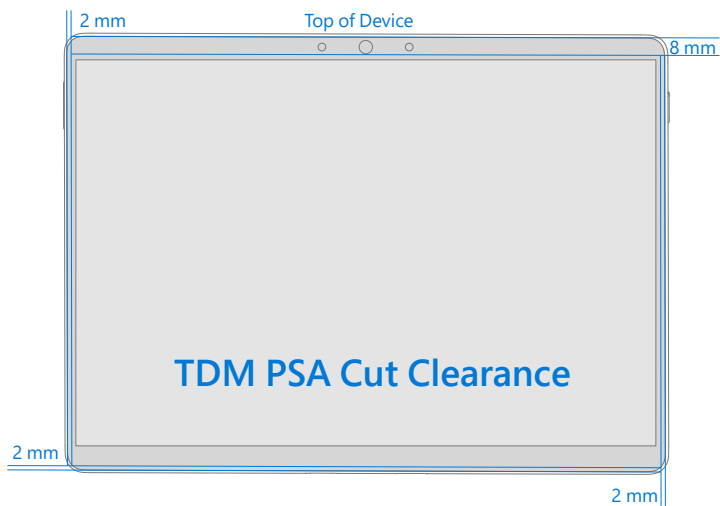

4. **Separate TDM from IBC** – Gently pull up vertically on the top edge of the glass while pushing down on the IBC to separate the glass. Lift the edges of the TDM and inspect for any remaining PSA. Slice or remove (with an iFixit Pick) any strands still connecting the TDM to the IBC.

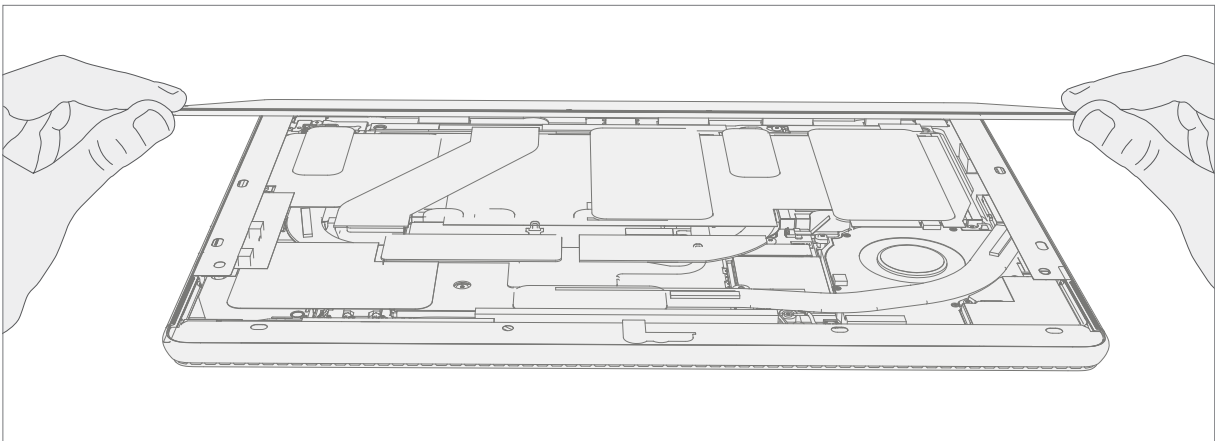

5. **Disconnect TDM FPC** – While supporting the TDM with one hand, remove the shield lid on the TDM FPC by inserting pointed end of a spudger underneath the inner edge the of the shield. Then gently pull upwards and the shield will come off. Disconnect the TDM FPC using the pointed end of a spudger. Do not pull on the FPC to disconnect.

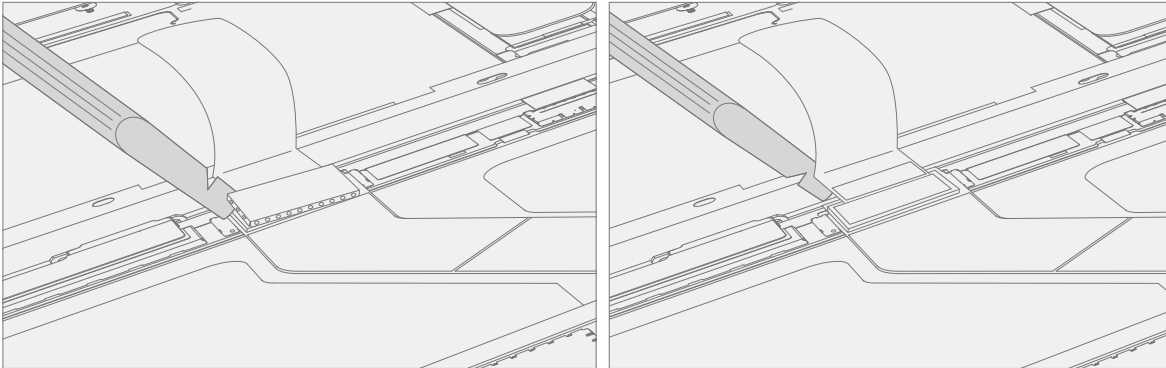

6. **Remove Speaker Mesh from IBC** – Remove any remaining speaker mesh from the IBC. Use a handheld pick to remove it by inserting the pick between the Speaker mesh and the enclosure. Confirm a successful removal of the speaker mesh and its adhesive by verifying the three cutouts of the IBC are exposed, as shown below.

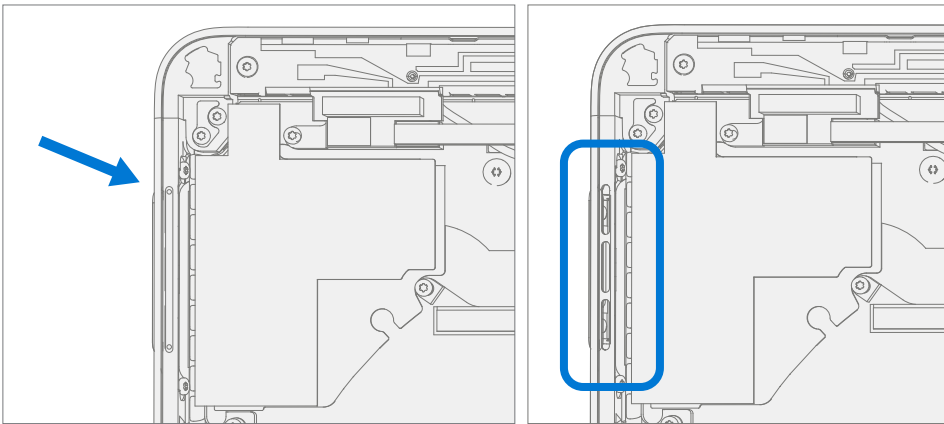

7. **Remove Residual IBC PSA** – Using IPA and cotton swabs clean residual PSA off the IBC. Ensure area around the Camera and IR Sensor is clean and free of any dust or other contamination. Wipe the area around the camera with a lint free cloth.

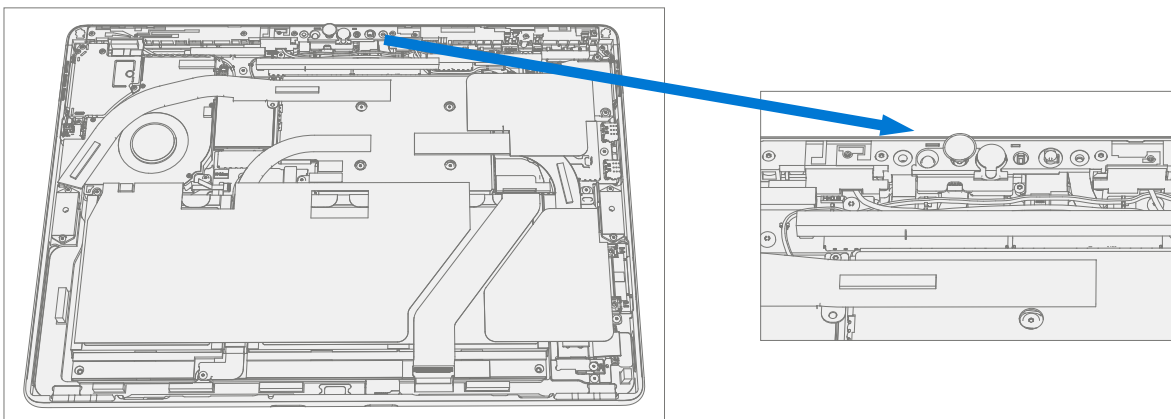

Procedure – Installation (TDM)

1. Pre-installation Device Inspection

- ⚠ **WARNING:** Verify the battery's condition refer to the M1153910 In Device Battery Inspection process. Devices exhibiting battery issues as outlined in the Battery Inspection Process require whole unit replacement.
- ✍ **IMPORTANT:** Leave protective cling on **new TDM** during all installation steps.
- ✍ **IMPORTANT:** Carefully inspect the internal areas of the bucket. Ensure the area around battery is free of any foreign objects.

- ### 2. TDM PSA Application
- Thoroughly clean the IBC along the TDM PSA bonding surface using IPA and a cotton swab. Wait at least 30 seconds before applying new PSA. Apply the 4 strips of PSA to the IBC. Align the PSA following the outline on the IBC. Leave the blue liner on the PSA, it will be removed at a later step. Refer to the below illustration for PSA locations.

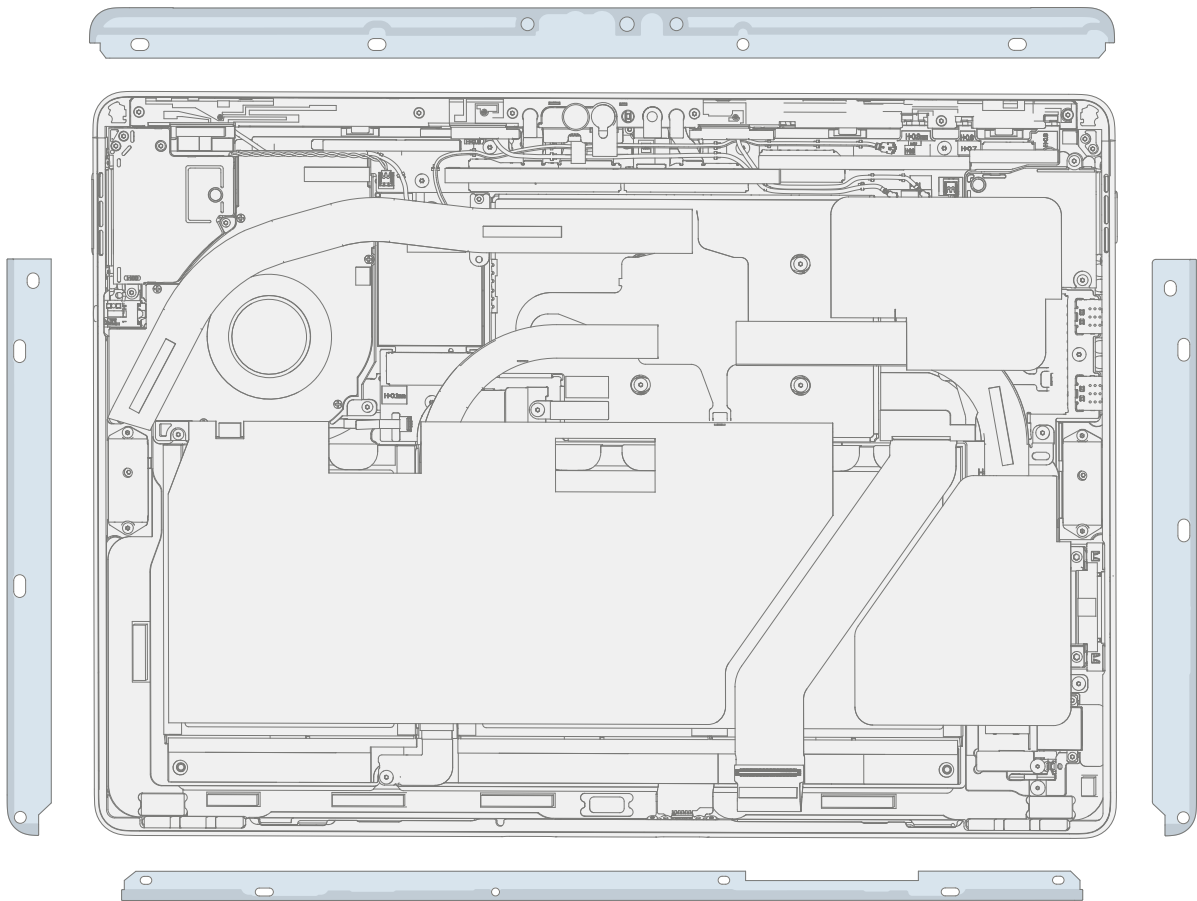

3. **Speaker Mesh Application** – Place the TDM face-down on a Soft ESD safe mat. Wipe down the outer edges of the TDM with a lint free cloth. When installing the **originally removed TDM** ensure outer edges are clean and clear of PSA residue. Remove the protective liner from the speaker mesh. Using the clear handle align the speaker mesh into the TDM speaker opening. Press onto the mesh for 10 seconds to activate the adhesive. Carefully remove the clear handle. Repeat this process for the other side of the TDM.

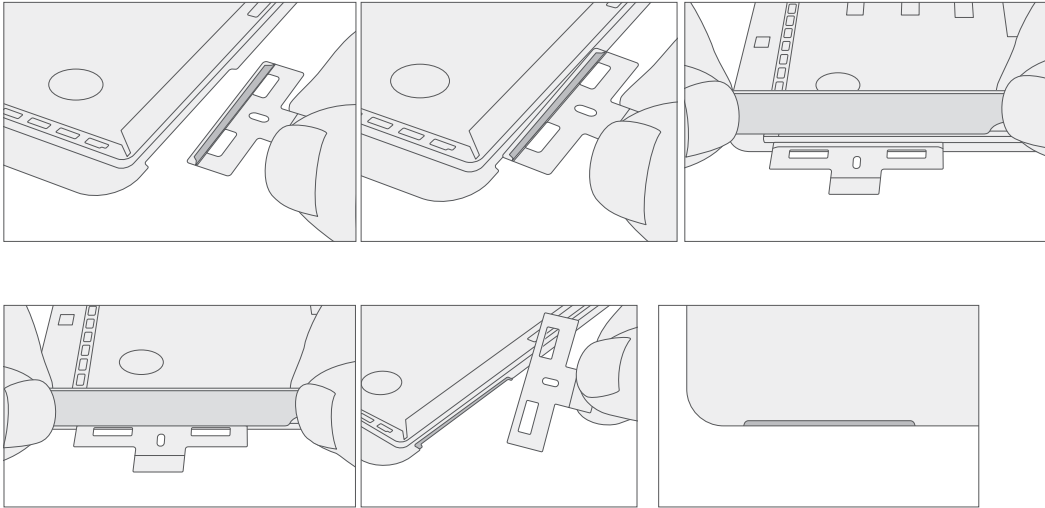

4. **Connect TDM FPC** – While supporting the TDM with one hand, connect the TDM FPCs by pressing it into the mating connector on the reverse side of the TDM. Install a new shield over the TDM FPC. Ensure all edges of the shield are snapped into place

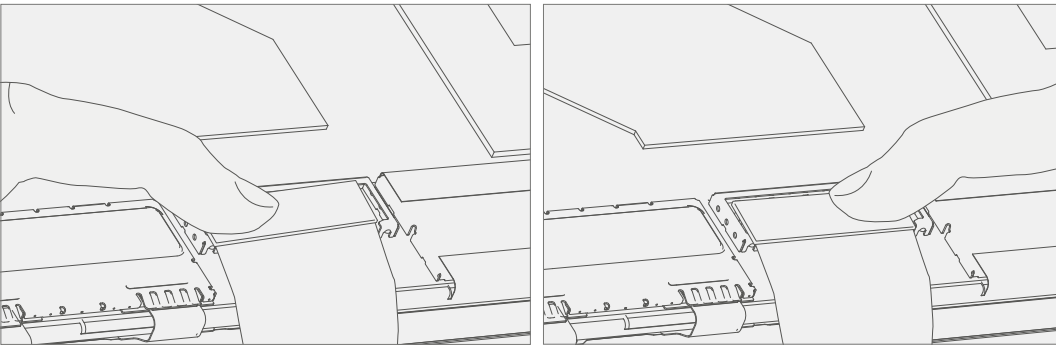

5. **Apply TDM to Bucket** – Hover the TDM and remove the PSA Liners to expose adhesive. Turn the TDM over and place it on the IBC. Align the TDM along the top edge first (Toe-in) and lower after alignment is found. Ensure that the glass sits flush in the IBC and does not rest anywhere on top of the IBC lip.

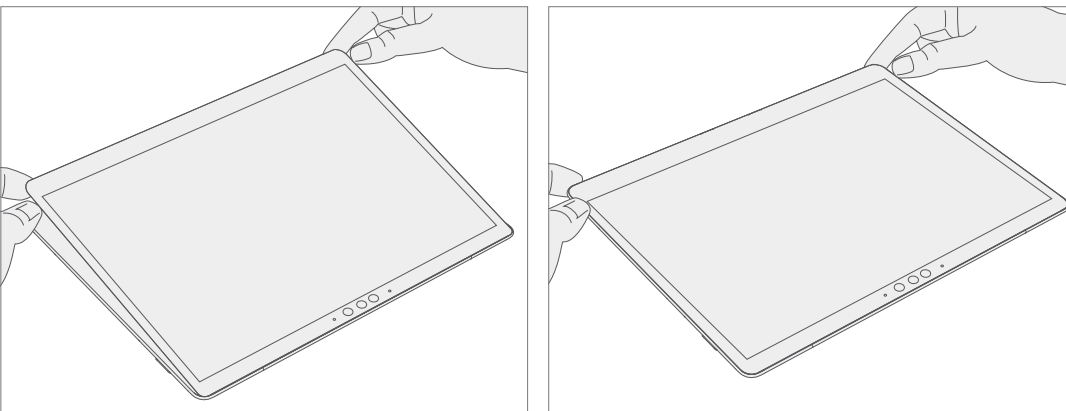

6. **Bonding PSA** – Place the bonding frame on the device, ensuring that the cutouts on the sides line up with the volume/power buttons. Place foam pad over bonding frame. Place the 23 kg of weight on top of the foam pad and bonding frame. Leave weight in place for 1 minute.

 **IMPORTANT:** Weight Requirement:

Minimum 23 kg (50 lb) / Maximum 26 kg (57 lb)

Minimum Dimensions: 280 mm x 200 mm

Geometry must be symmetrical, to allow for even weight distribution. Weight used must be a flat plate, with consistent flatness and not protrude from contact plane with Bonding Frame.

Weight must contact the full perimeter of the frame when placed above it. Recommended weights (Ruck Plates of 9 kg + 14 kg)

When using Ruck weights place the 14 kg weight first, then stack the 9 kg weight on top.

Ensure foam pad covers entire bonding frame.

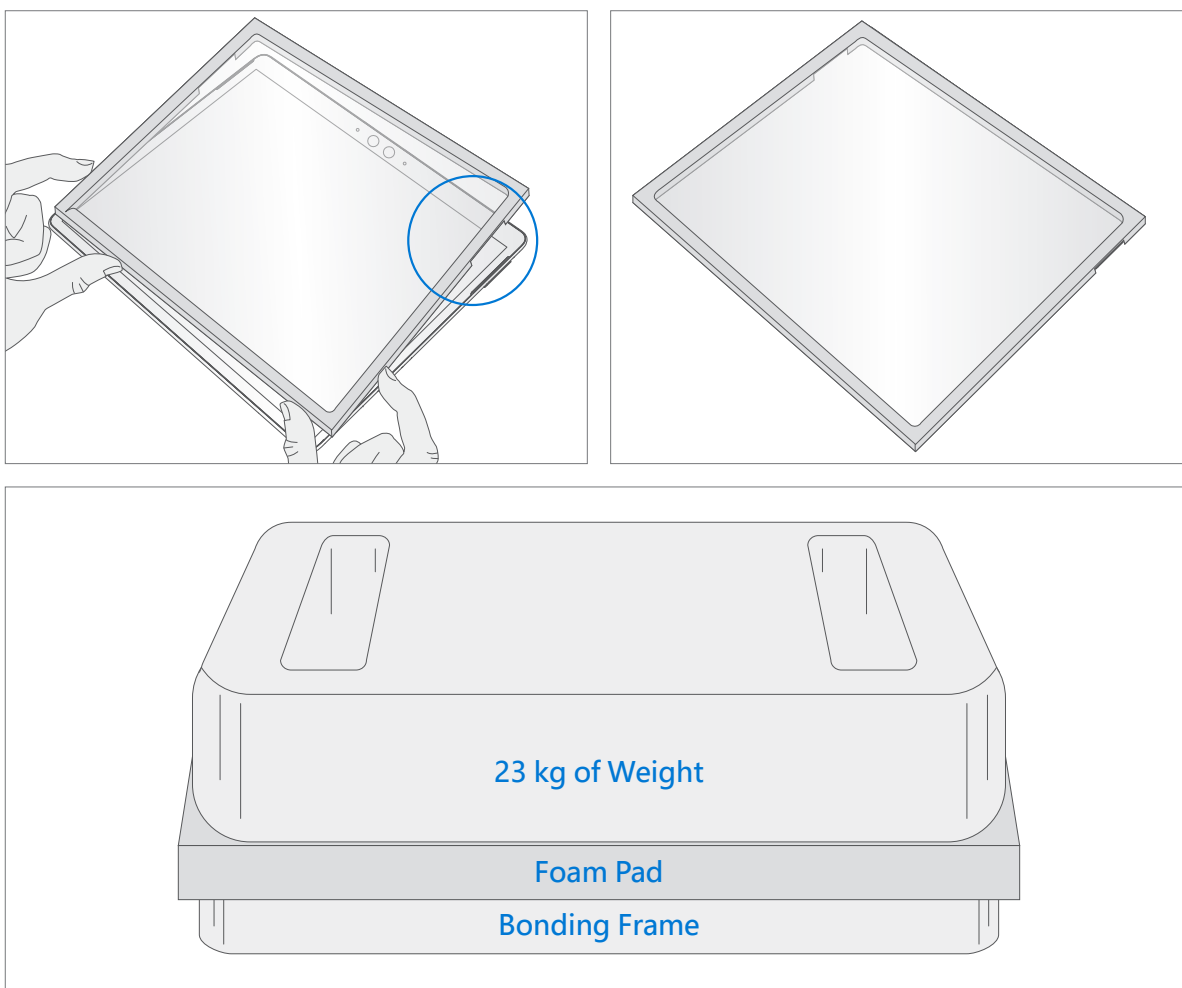

7. **After Bonding Inspection** – Remove the weights, foam pad, and the frame. Lift carefully to avoid damaging the device. Inspect the TDM for scratches, cracks, large gaps, and its flushness with respect to the IBC.
8. **Install rSSD** – Install the rSSD as detailed in the Procedure – Installation (rSSD) ([page 16](#)).
9. **New TDM Calibration** – On installation of a **new TDM** device final calibration relies on the successful completion of the TDM Replacement Mode. TDM calibration is not required when installing the originally removed TDM.
 - a. **Connect software tools USB drive** with SDT to USB connector on device under repair.
 - b. **Power on device** – Depress the power button on the side of the device.
 - c. **Run software tool** – At the device OS, use Windows Explorer, navigate to USB drive and run:
SDT – Select Repair setup and validation. Run the Touch Display Calibration. Accept the restart prompt at the end of the tool process.

 **IMPORTANT:** This step must be carried out on the device successfully on installation of a **new TDM**. Ensure light levels in the work area remain consistent during the touch display calibration process. Any tool failures require restarting the process with a new TDM.

10. **Run SDT** – Run SDT to ensure all device features and functions operate as expected.
11. **Final inspection TDM installation** – Remove protective cling from the new TDM. Verify the side edges of the TDM are flush, and that there are no obvious steps/gaps between the TDM and the IBC. Wipe the device thoroughly (including under the kickstand) with the microfiber cloth to remove all fingerprints.



Procedure – Alternate Installation (TDM)

1. Pre-installation Device Inspection

- ⚠ **WARNING:** Verify the battery's condition refer to the M1153910 In Device Battery Inspection process. Devices exhibiting battery issues as outlined in the Battery Inspection Process require whole unit replacement.
- ✍ **IMPORTANT:** Leave protective cling on **new TDM** during all installation steps.
- ✍ **IMPORTANT:** Carefully inspect the internal areas of the bucket. Ensure the area around battery is free of any foreign objects.

2. **TDM PSA Application** – Thoroughly clean the IBC along the TDM PSA bonding surface using IPA and a cotton swab. Wait at least 30 seconds before applying new PSA. Apply the 4 strips of PSA to the IBC. Align the PSA following the outline on the IBC. Leave the blue liner on the PSA, it will be removed at a later step. Refer to the below illustration for PSA locations.

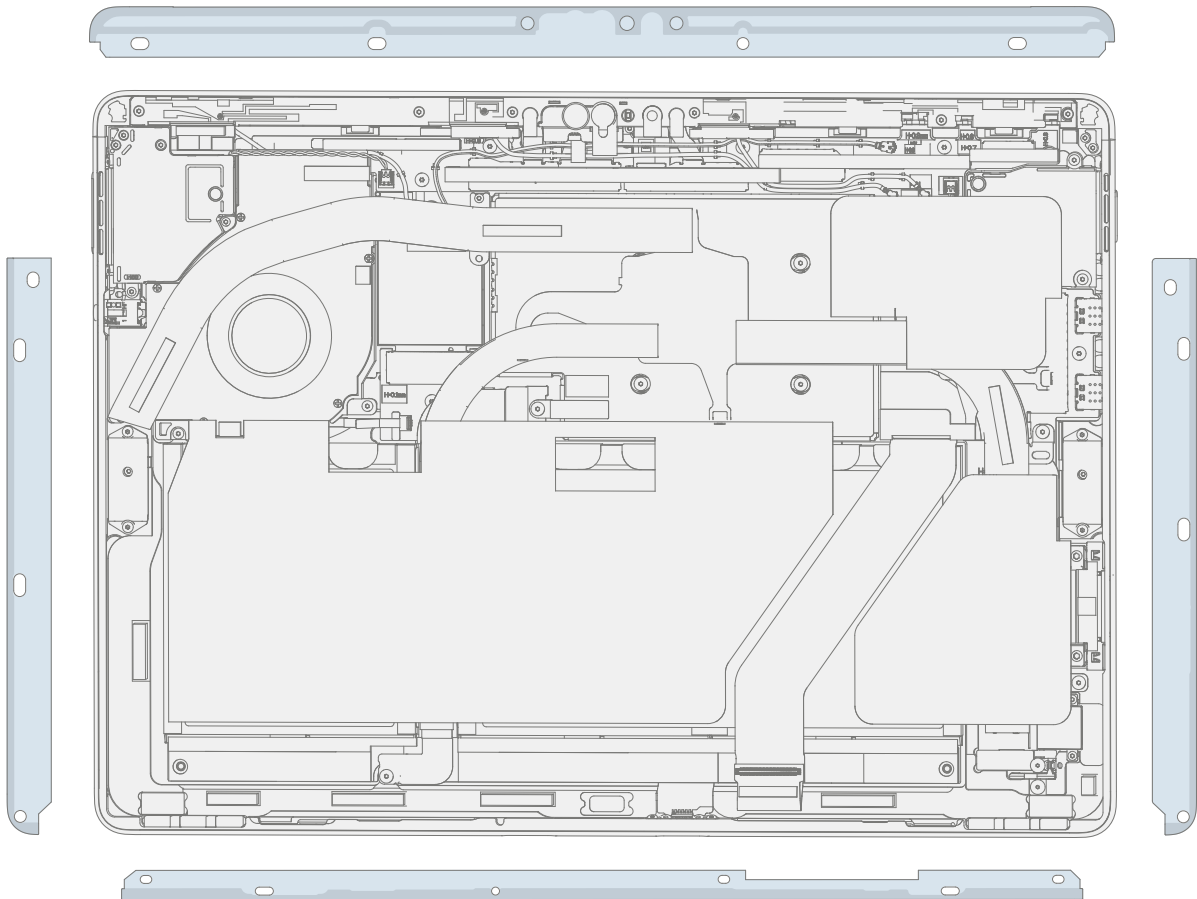

3. **Speaker Mesh Application** – Place the TDM face-down on a Soft ESD safe mat. Wipe down the outer edges of the TDM with a lint free cloth. When installing the **originally removed TDM** ensure outer edges are clean and clear of PSA residue. Remove the protective liner from the speaker mesh. Using the clear handle align the speaker mesh into the TDM speaker opening. Press onto the mesh for 10 seconds to activate the adhesive. Carefully remove the clear handle. Repeat this process for the other side of the TDM.

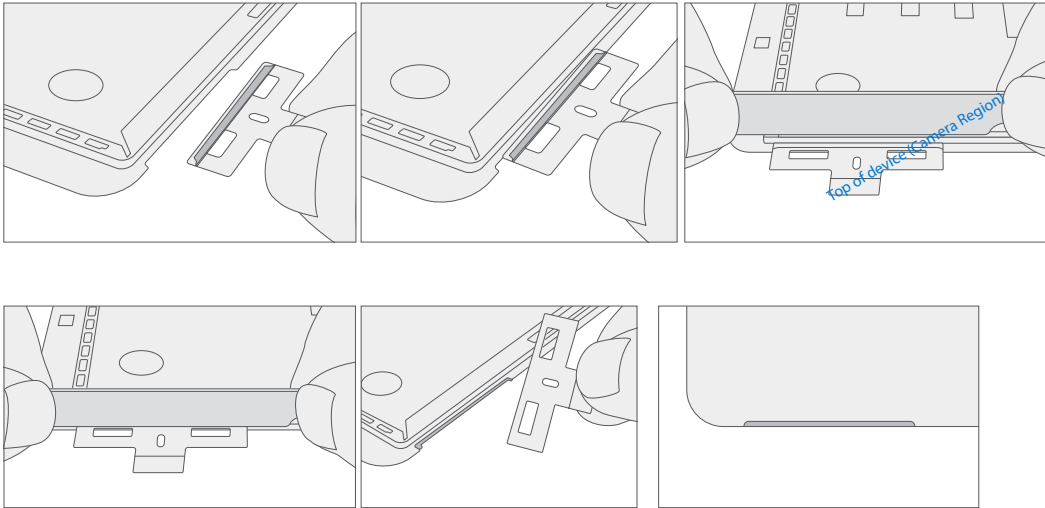

4. **Connect TDM FPC** – TBD While supporting the TDM with one hand, connect the TDM FPCs by pressing it into the mating connector on the reverse side of the TDM. Install a new shield over the TDM FPC. Ensure all edges of the shield are snapped into place.

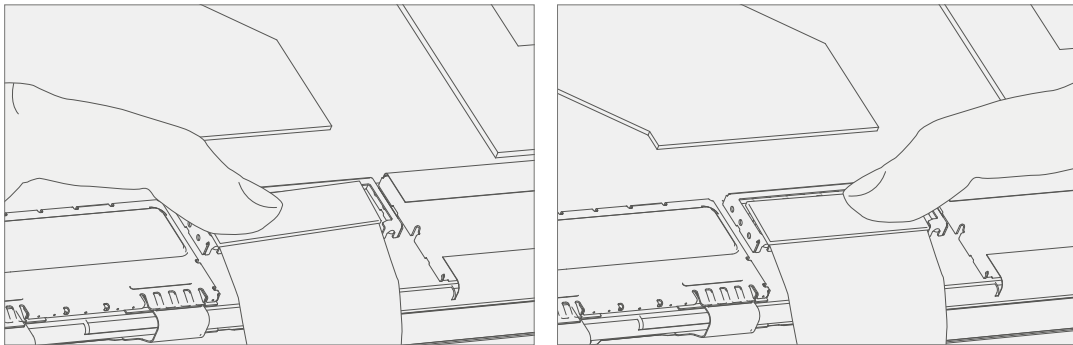

5. **Apply TDM to Bucket** – Hover the TDM and remove the PSA Liners to expose adhesive. Turn the TDM over and place it on the IBC. Align the TDM along the top edge first (Toe-in) and lower after alignment is found. Ensure that the glass sits flush in the IBC and does not rest anywhere on top of the IBC lip. Lightly press on the edges of the TDM to create an initial bond.

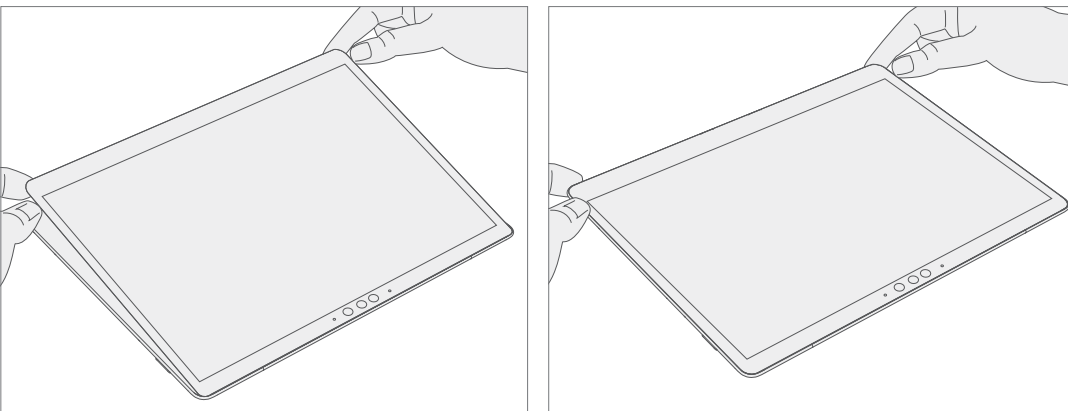

6. **Alternate Bonding PSA** – Bonding is a multi-step process. Refer to the below illustrations.

 **IMPORTANT:** Use steel shot bags, one 9 kg and one 14 kg. Apply the 9 kg bag, and then the 14 kg bag.

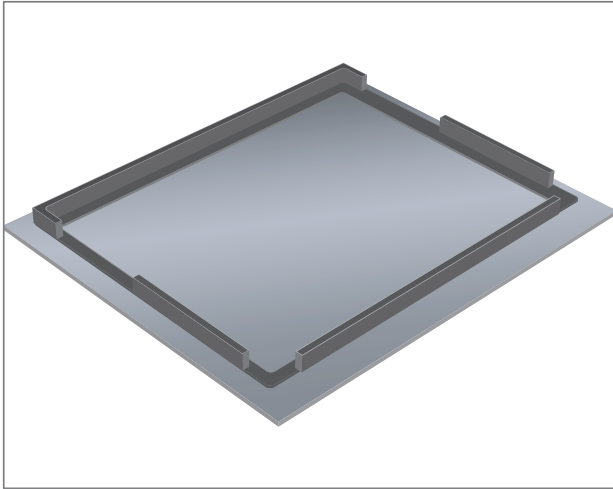

Foam pad with bonding frame face down

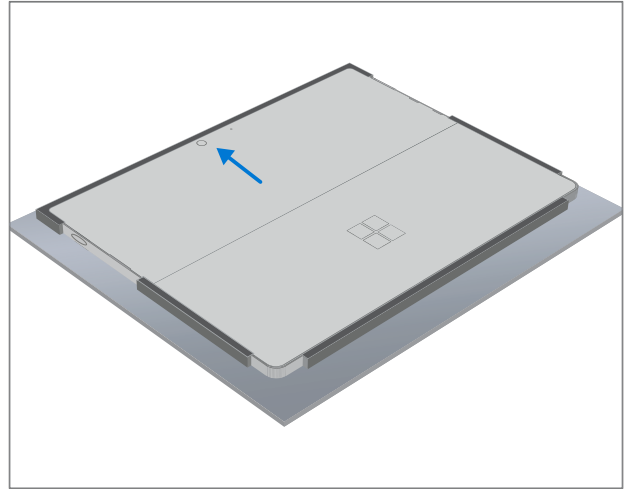

Place device display side down into bonding frame

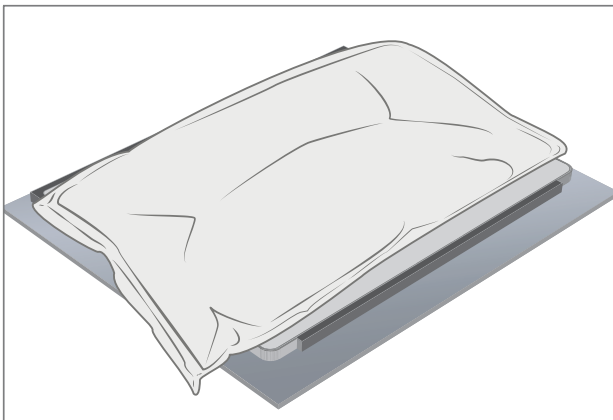

Place 9 kg steel shot bag onto device

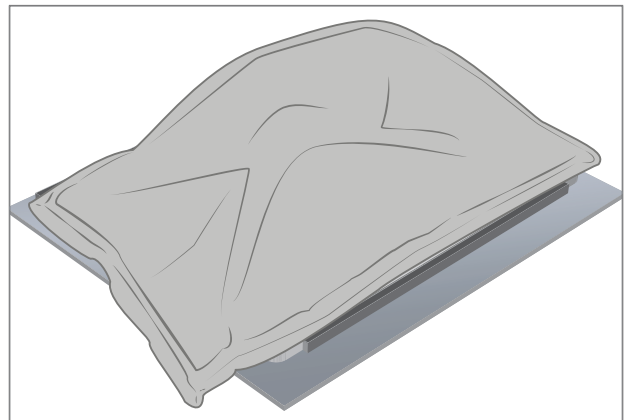

Place 14 kg steel shot bag onto 9 kg steel shot bag
Bond for 1 minute



7. **After Bonding Inspection** – Remove the steel shot bags and lift device out of the frame. Lift carefully to avoid damaging the device. Inspect the TDM for scratches, cracks, large gaps, and its flushness with respect to the IBC.
8. **Install rSSD** – Install the rSSD as detailed in the Procedure – Installation (rSSD) (page 16).
9. **New TDM Calibration** – On installation of a **new TDM** device final calibration relies on the successful completion of the TDM Replacement Mode. TDM calibration is not required when installing the originally removed TDM.
 - a. **Connect software tools USB drive** with SDT to USB connector on device under repair.
 - b. **Power on device** – Depress the power button on the side of the device.
 - c. **Run software tool** – At the device OS, use Windows Explorer, navigate to USB drive and run: **SDT** – Select Repair setup and validation. Run the Touch Display Calibration. Accept the restart prompt at the end of the tool process.

! **IMPORTANT:** This step must be carried out on the device successfully on installation of a new TDM. Ensure light levels in the work area remain consistent during the touch display calibration process. Any tool failures require restarting the process with a new TDM.

10. **Run SDT** – Run SDT to ensure all device features and functions operate as expected.
11. **Final inspection TDM installation** – Remove protective cling from the TDM. Verify the side edges of the TDM are flush, and that there are no obvious steps/gaps between the TDM and the IBC. Wipe the device thoroughly (including under the kickstand) with the microfiber cloth to remove all fingerprints.



THM Replacement Process

Preliminary Requirements

 **IMPORTANT:** Be sure to follow all special (bolded) notes, cautions, & warnings in each process section.

Required Tools and Components

- **Tools:**
 - 3IP (Torx-Plus) driver
 - Anti-static wrist strap (1M Ohm resistance)
 - Soft ESD safe mat
 - SIM eject tool (or equivalent 0.023 in / 0.58 mm diameter paperclip)
 - Isopropyl alcohol dispenser bottle (use 91% or greater IPA)
 - Cotton swab
 - USB drive with Surface Diagnostic Toolkit
 - Spudger
 - iFixit opening tool
 - Plastic tweezers
 - TDM PSA debonding tool (M1214770-001)
 - TDM PSA bonding frame (M1178722-001)
 - Foam Pad
(Material: EVA Foam, Thickness: 9.5 mm, Density: 0.03 g/cm³, Minimum 229 mm x 305 mm)
(Recommended McMaster PN: [86095K43](#))
 - TDM bonding weights 23 kg (Recommended using two Ruck weights, one 9 kg, one 14 kg)
(Alternate using steel shot bags one 9 kg, one 14 kg)
- **Components:**
 - WiFi or LTE THM (Refer to [Illustrated Service Parts List](#))

Prerequisite Steps:

- **Power off device** – Ensure device is powered off and disconnected from a power supply.
- **General Safety** – Check to make sure that general guidelines and ESD compliance steps are followed prior to opening device. Refer to Prior to Device Disassembly section ([page 14](#)) for details.
- **Remove TDM** – Remove the TDM as detailed in the Procedure – Removal (TDM) ([page 31](#)).



Procedure – Removal (THM)

1. **Disconnect fan from PCBA** – Using plastic spudger release the locking bar and slide zif connector from the PCBA.

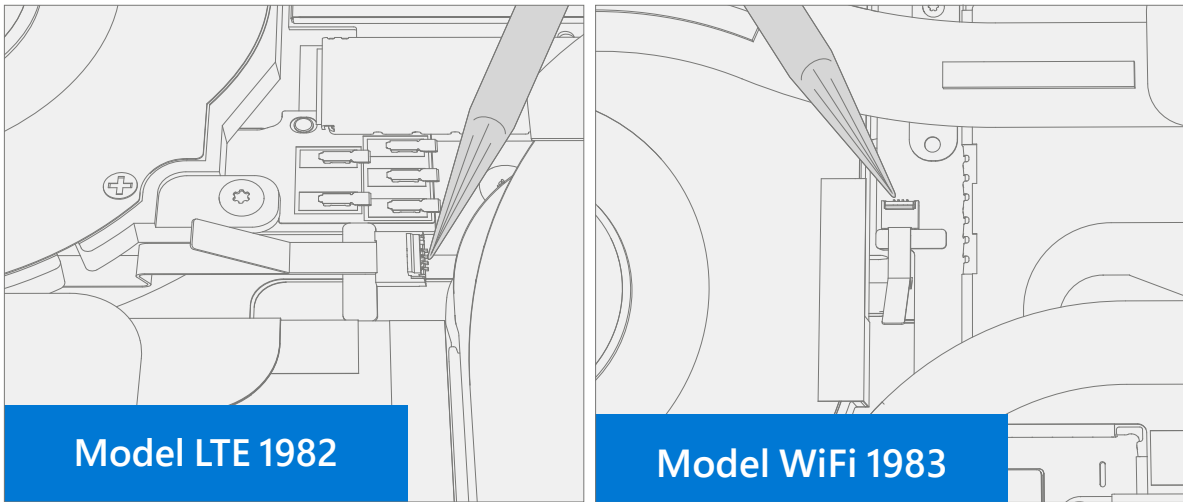

2. **THM screw removal** – Use a 3IP (Torx plus) driver to remove the 12 THM screws.

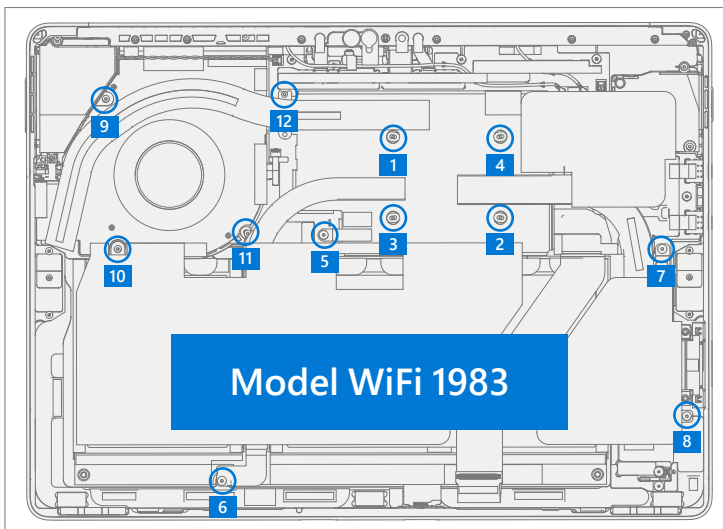
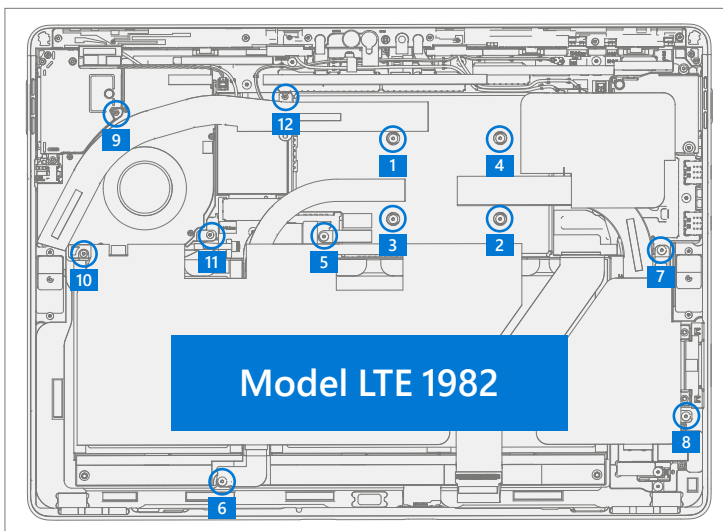

3. **Model 1983 WiFi Remove left side speaker tape** – Remove tape securing speaker cable to the fan.

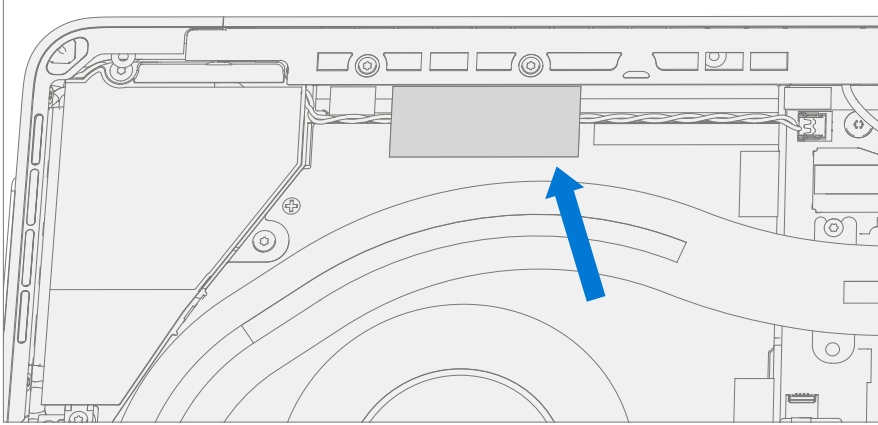

4. **Release TIM from PCBA** – Using a plastic spudger apply light pressure to the edges of the THM copper shield on the PCBA as pictured below. Carefully lift THM from the center copper shield and fan area. Note that shield spring gasket may also come off with the THM copper shield.



5. **Clean TIM from SoC** – Using a plastic spudger, scrape TIM from SoC area. Use IPA and cotton swab to clean SoC of residual TIM.

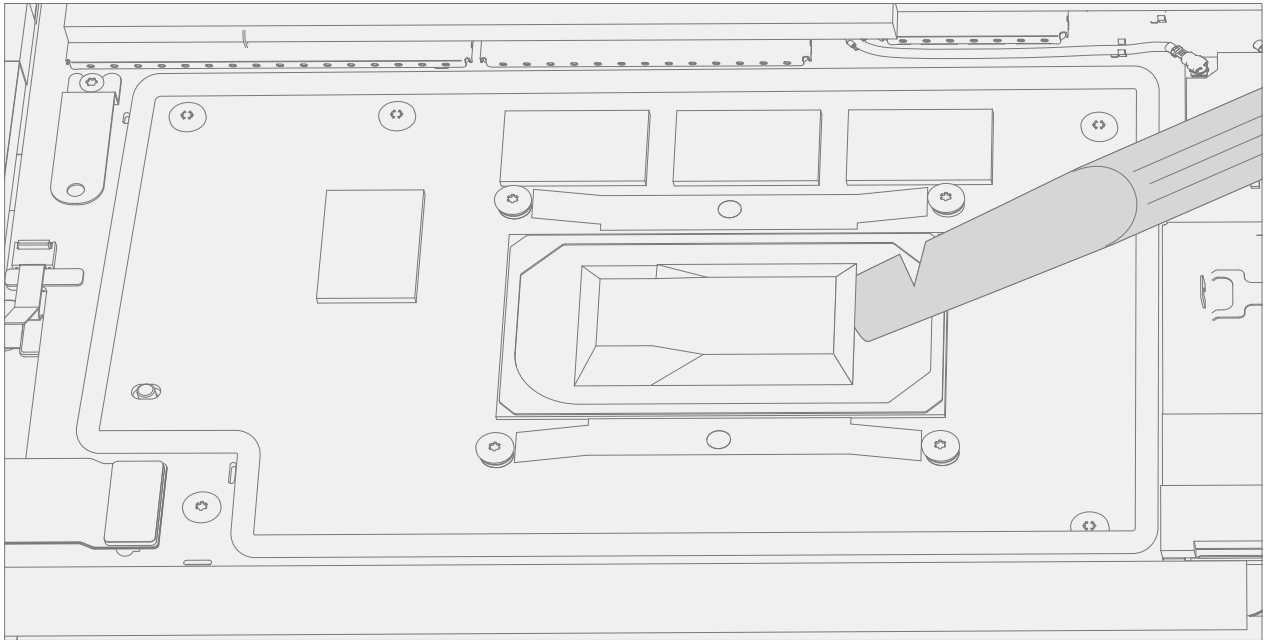

Procedure – Installation (THM)

1. **Spring gasket placement** – If the original gasket appears damaged replace it with a new spring gasket. Ensure the spring gasket is correctly placed over the PCBA then center and align the THM copper shield to the spring gasket.

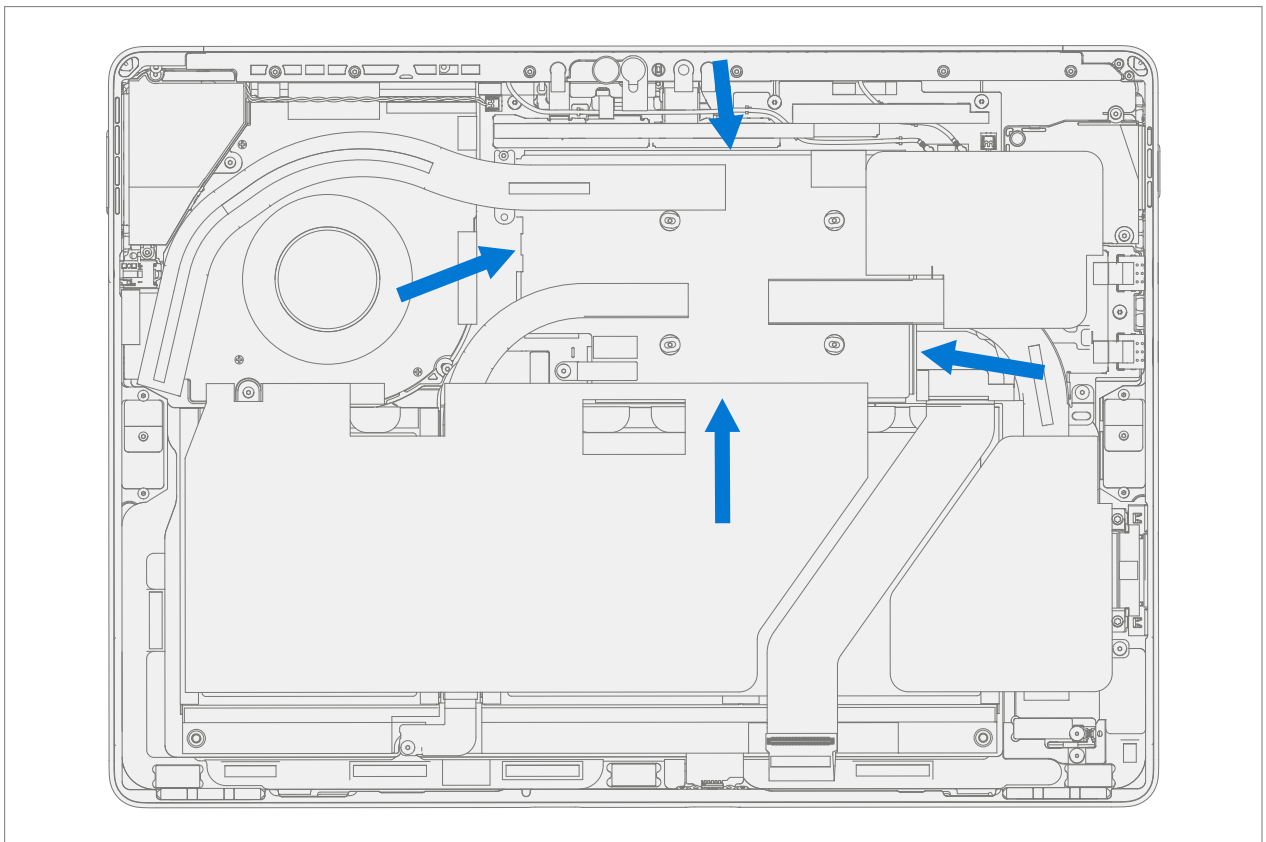
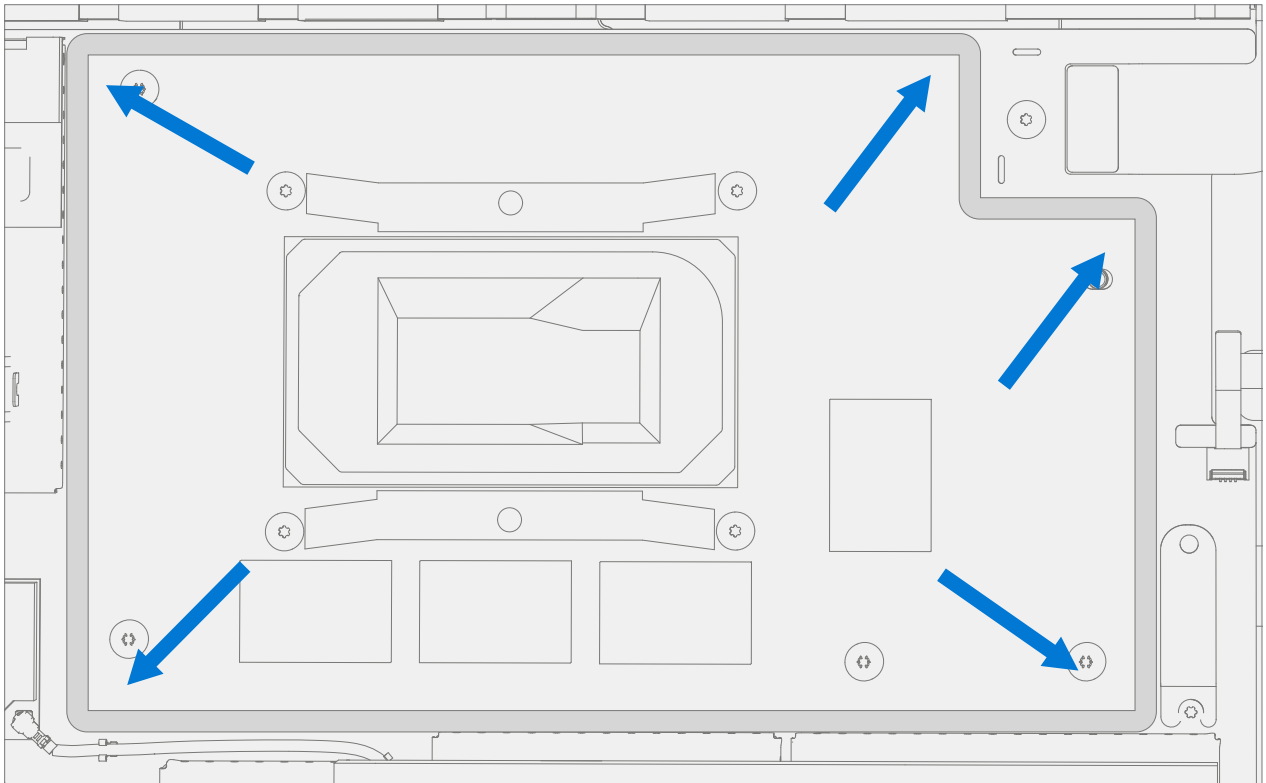

2. **Secure copper shield to gasket** – Press THM along edges of copper shield cover to snap it in place over the PCBA.

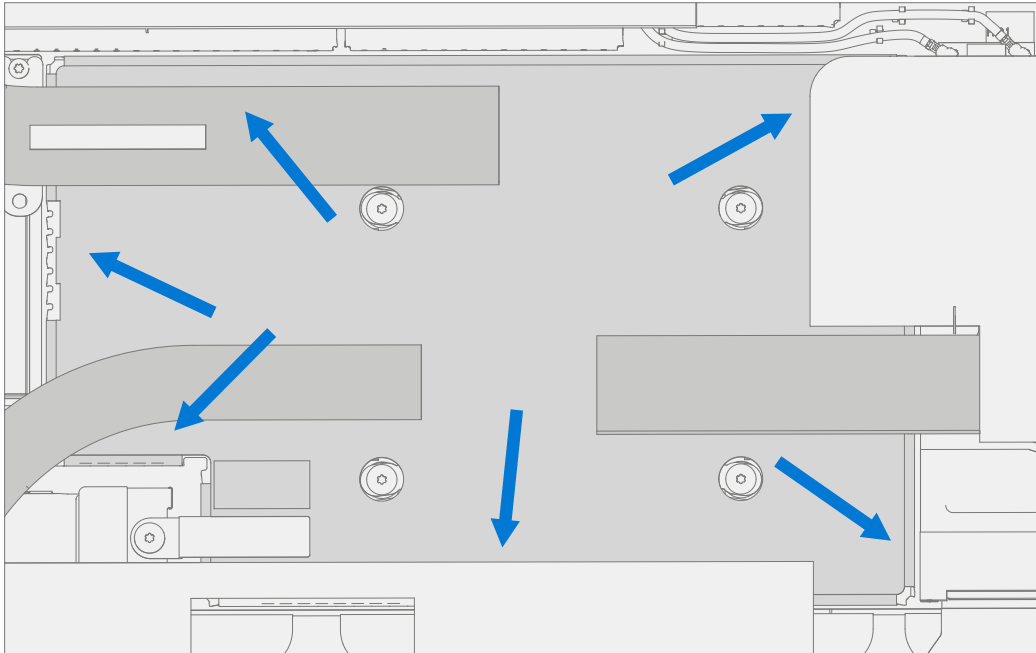

3. **Install new THM screws Model LTE 1982** – Use a 3IP (Torx-Plus) driver to install the 12 screws until just snug and seated, and then turn another 45 degrees (1/8 turn) or until screws are fully fastened. Refer to the below illustration for screw locations and part numbers. Alternate part numbers in parenthesis.

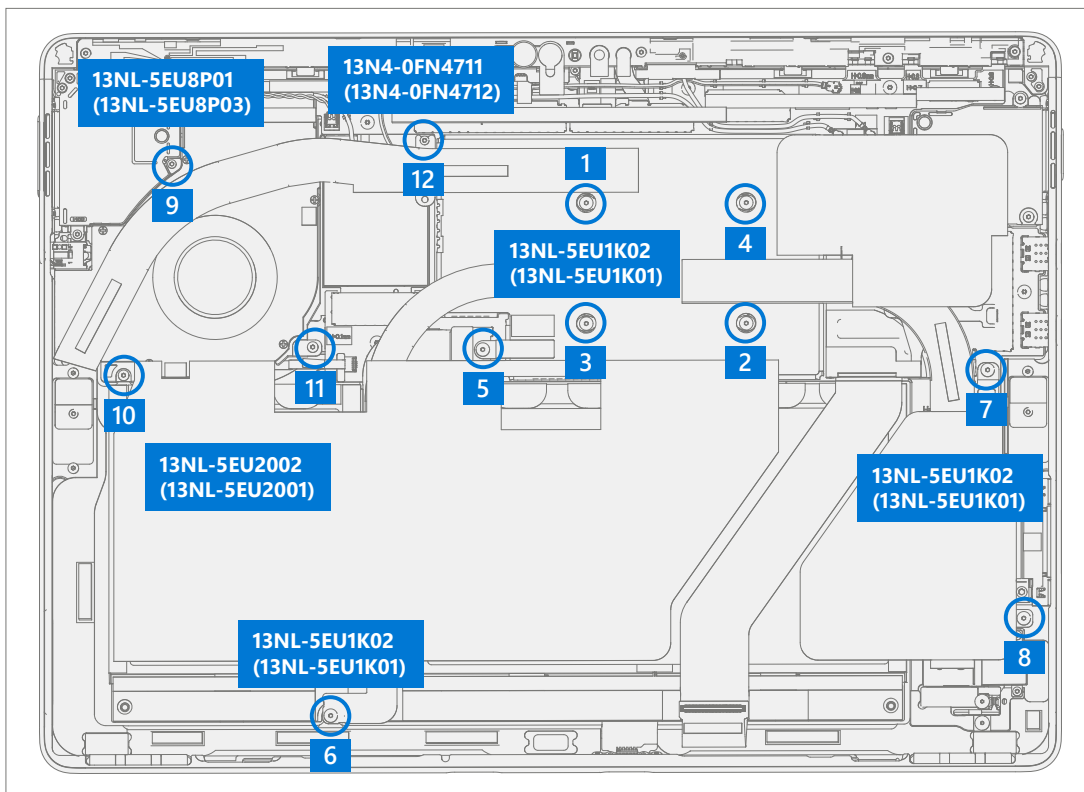

4. **Install new THM screws Model WiFi 1983** – Use a 3IP (Torx-Plus) driver to install the 12 screws until just snug and seated, and then turn another 45 degrees (1/8 turn) or until screws are fully fastened. Refer to the below illustration for screw locations and part numbers. Alternate part numbers in parenthesis.

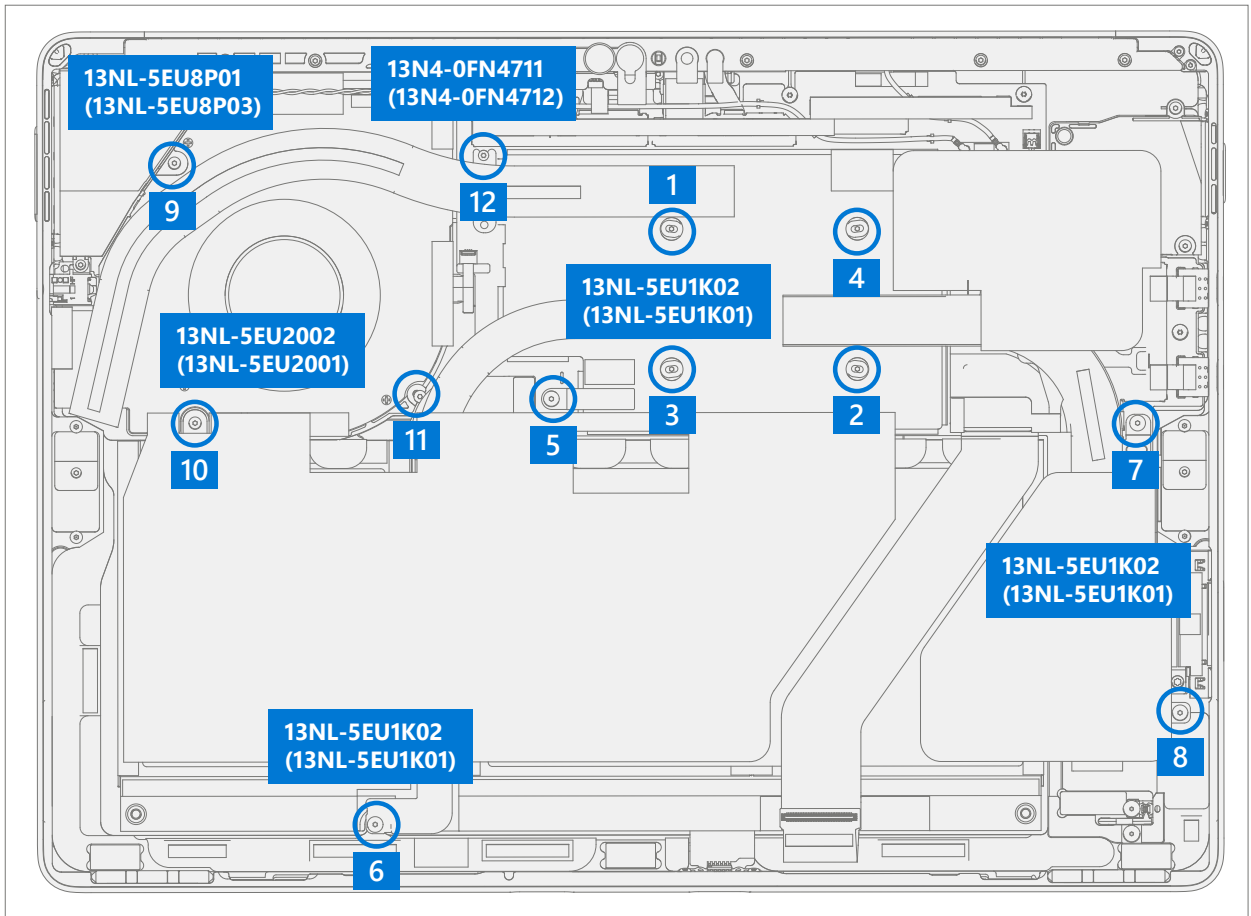

5. **Apply left side fan foams Model LTE 1982** – Install new foam strip as pictured below.

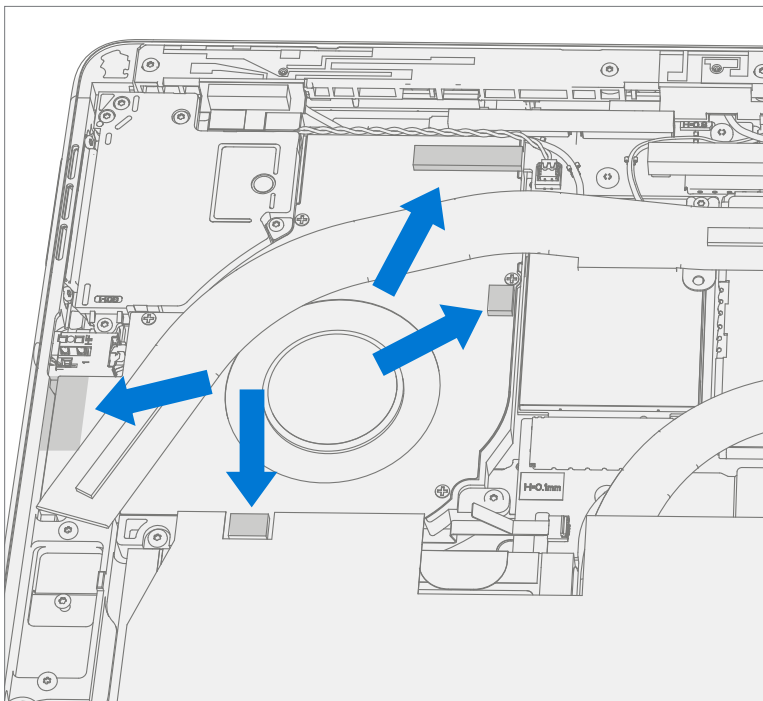

6. **Apply left side speaker tape and foams Model WiFi 1983** – Install tape securing speaker cable to the fan. Install new foams as pictured below.

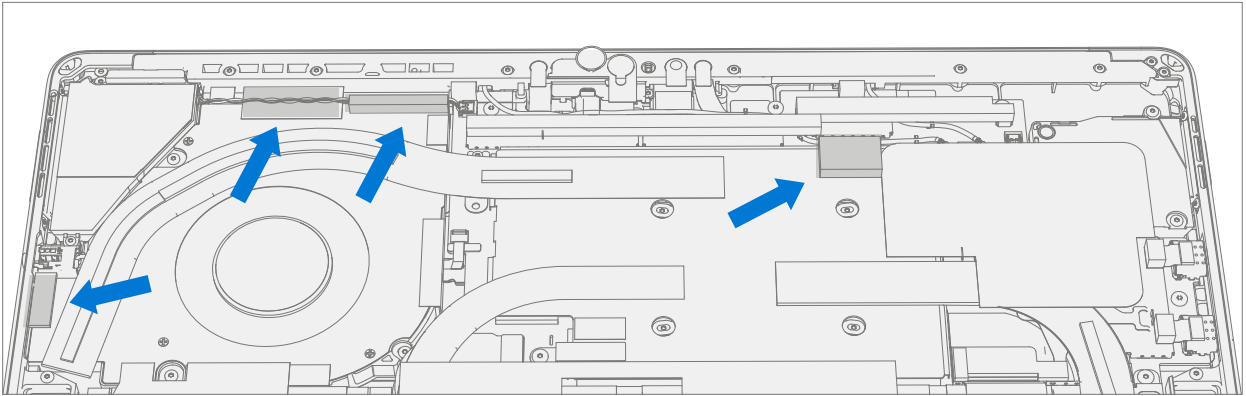

7. **Connect fan to PCBA** – Ensure the fan connector locking tab is up. Slide the fan FPC into the zif connector on the PCBA. Press down on the locking tab to secure it.

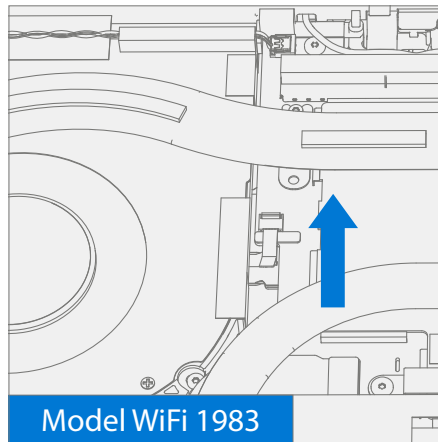
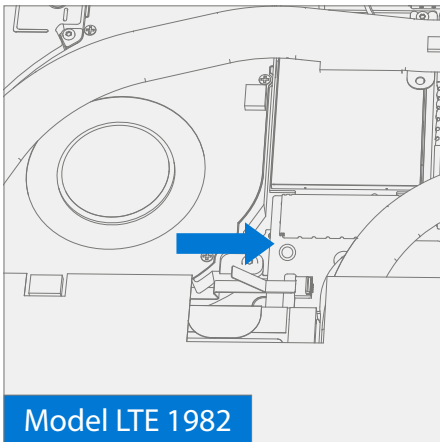

8. **Install TDM** – Install the TDM as detailed in the Procedure – Installation (TDM) ([page 36](#)).
9. **Run SDT** – Run SDT to ensure all device features and functions operate as expected.



Surflink Replacement Process

Preliminary Requirements

 **IMPORTANT:** Be sure to follow all special (bolded) notes, cautions, & warnings in each process section.

Required Tools and Components

- **Tools:**
 - 3IP (Torx-Plus) driver
 - 6IP (Torx-Plus) drive
 - Anti-static wrist strap (1M Ohm resistance)
 - Soft ESD safe mat
 - Microfiber / lint free cloth
 - SIM eject tool (or equivalent 0.023 in / 0.58 mm diameter paperclip)
 - Isopropyl alcohol dispenser bottle (use 91% or greater IPA)
 - Cotton swab
 - USB drive with Surface Diagnostic Toolkit
 - Spudger
 - iFixit opening tool
 - TDM PSA debonding tool (M1214770-001)
 - TDM PSA bonding frame (M1178722-001)
 - Foam Pad
(Material: EVA Foam, Thickness: 9.5 mm, Density: 0.03 g/cm³, Minimum 229 mm x 305 mm)
(Recommended McMaster PN: [86095K43](#))
 - TDM bonding weights 23 kg (Recommended using two Ruck weights, one 9 kg, one 14 kg)
(Alternate using steel shot bags: one 9 kg, one 14 kg)
- **Components:**
 - Surflink (Refer to [Illustrated Service Parts List](#))
 - Wifi or LTE THM (Refer to [Illustrated Service Parts List](#))

Prerequisite Steps:

- **Power off device** – Ensure device is powered off and disconnected from a power supply.
- **General Safety** – Check to make sure that general guidelines and ESD compliance steps are followed prior to opening device. Refer to Prior to Device Disassembly section ([page 14](#)) for details.
- **Remove TDM** – Remove the TDM as detailed in the Procedure – Removal (TDM) ([page 31](#)).
- **Remove THM** – Remove the THM as detailed in the Procedure – Removal (THM) ([page 45](#)).



Procedure – Removal (Surflink)

1. **Heat spreader tape removal** – Remove heat spreader tape covering Surflink. Note tape size is not the same between WiFi and LTE models. Refer to the below illustrations.

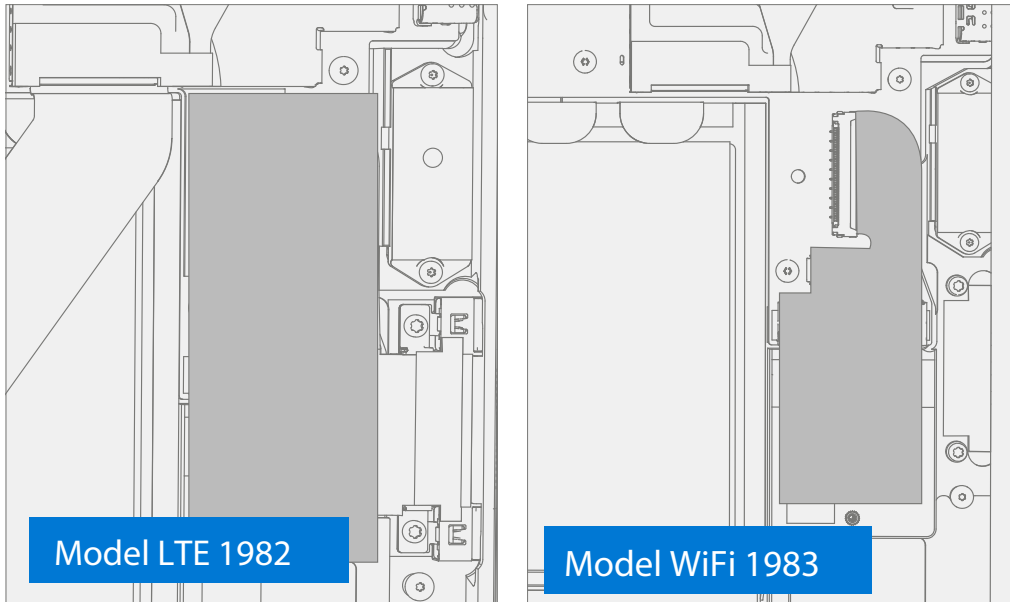

2. **Disconnect FPC from PCBA** – Use a spudger to release locking bar and disconnect Surflink connector from PCBA.

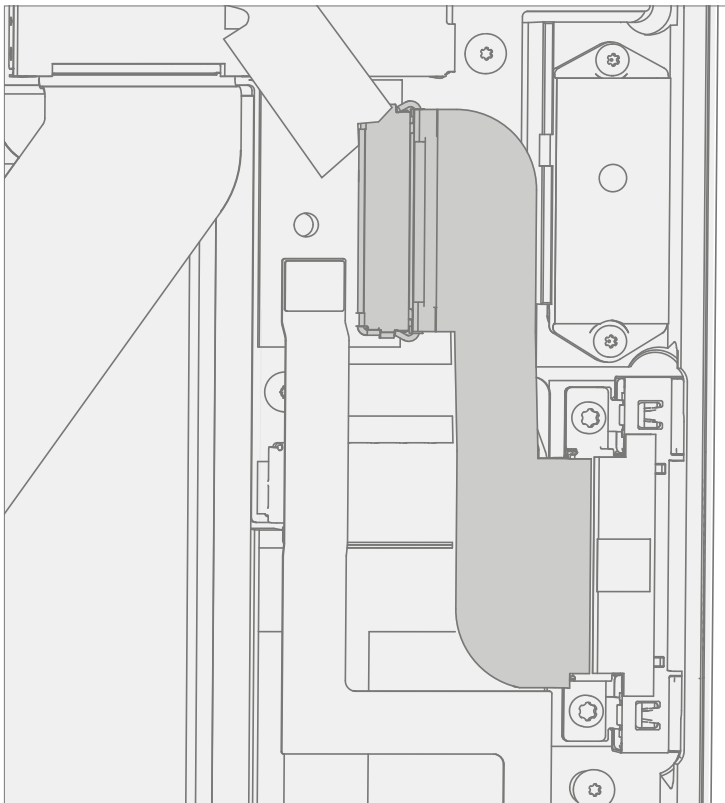

3. **Screw removal** – Use a 6IP (Torx plus) driver to remove the Surflink screws.

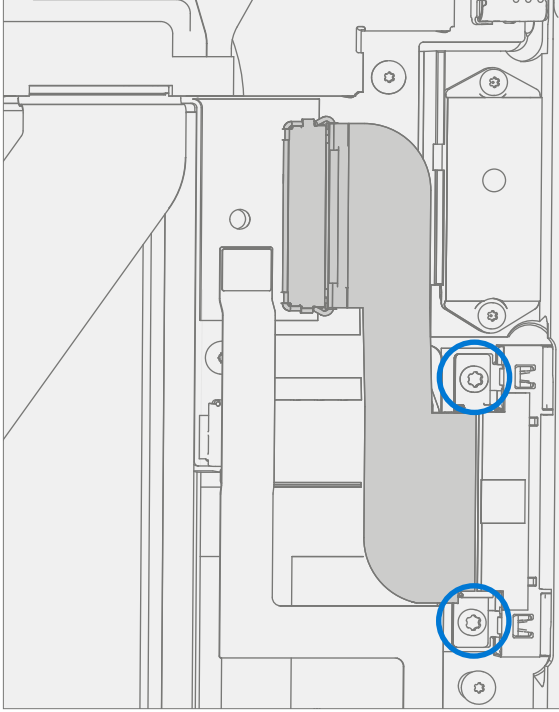

4. **Surflink removal** – Remove Surflink from IBC.

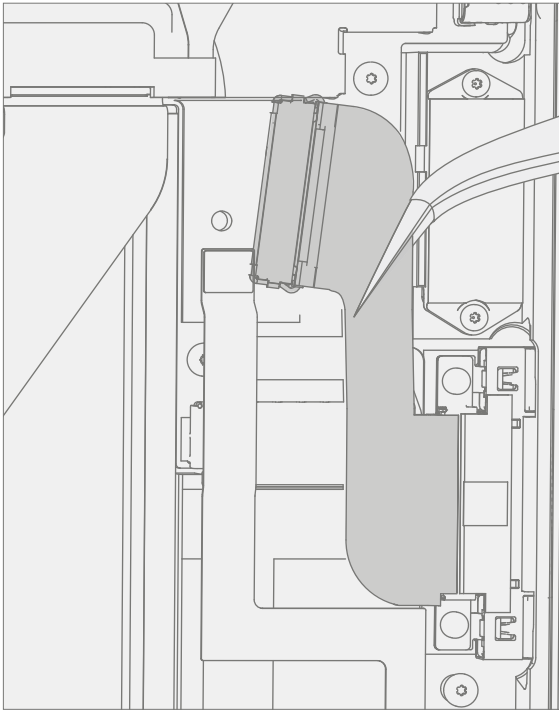

Procedure – Installation (Surflink)

1. **Install new Surflink** – Install new Surflink into IBC.

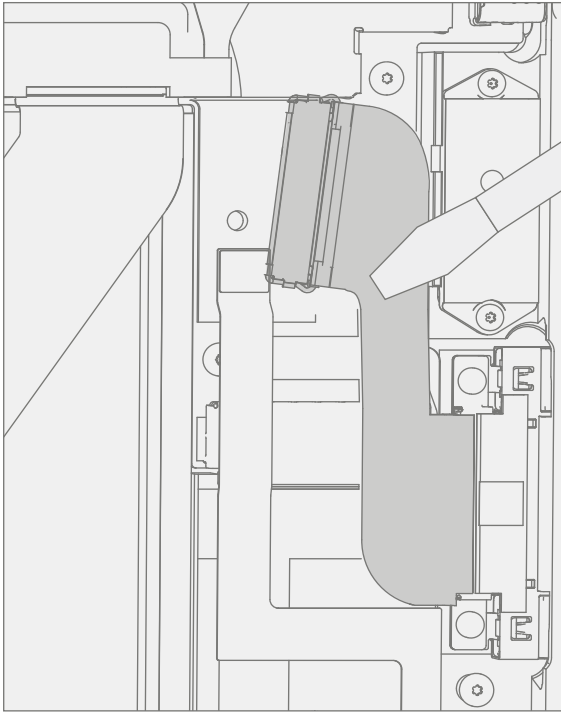

2. **Install screws** – Use a 6IP (Torx-Plus) driver to install the Surflink screws until just snug and seated, and then turn another 45 degrees (1/8 turn) or until screws are fully fastened. Refer to the below illustration for screw locations and part numbers. Alternate part numbers in parenthesis.

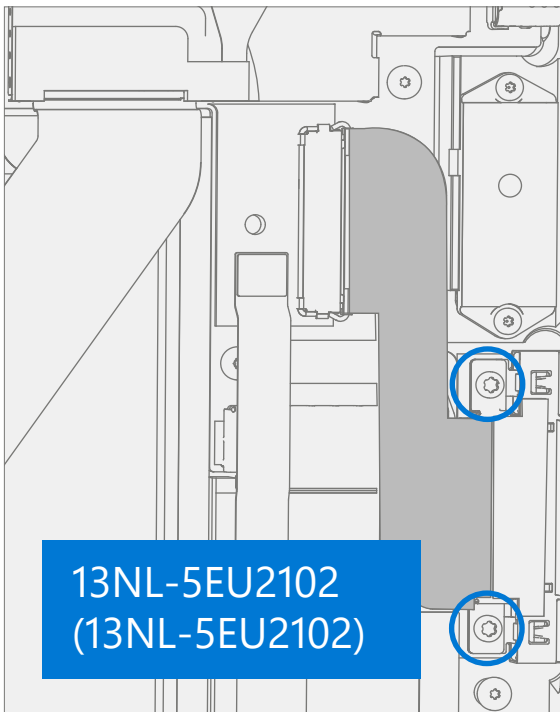

3. **Connect FPC to PCBA** – Connect Surfink cable to PCBA. Press down on the locking buckle to secure the connector.

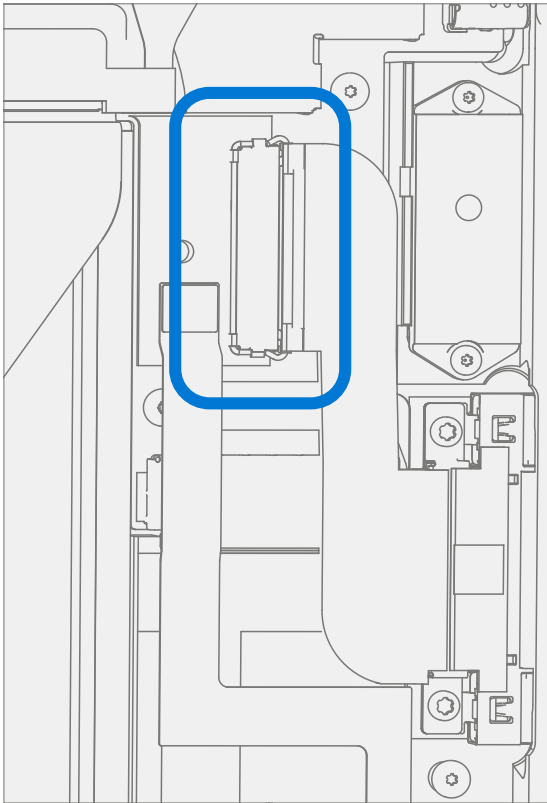

4. **Install new heat spreader tape** – Apply new heat spreader tape to the Surfink. Note tape size is not the same between WiFi and LTE models. Ensure the notched corners are aligned next to the battery. Refer to the below illustrations.

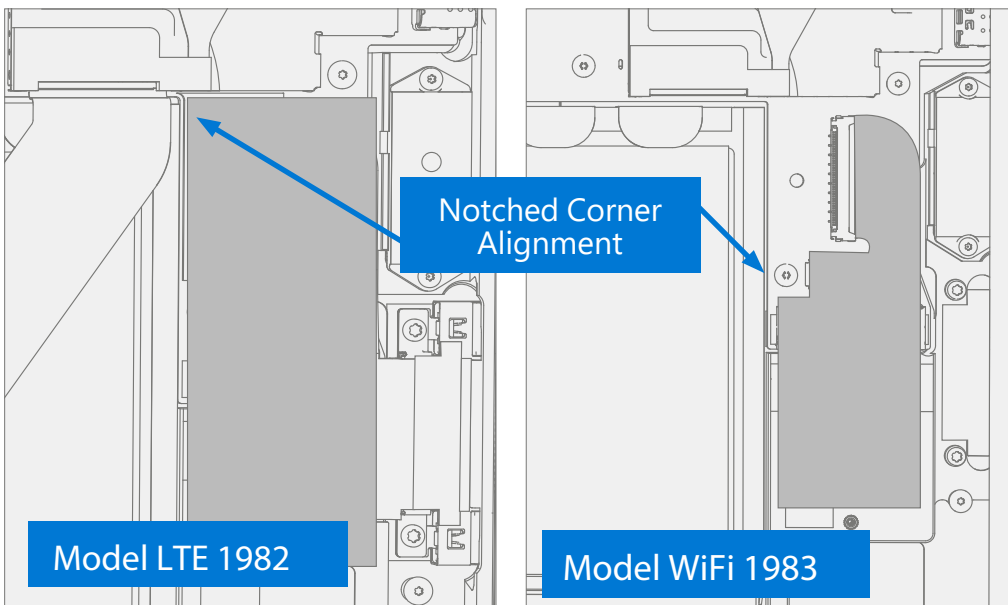

5. **Install THM** – Install the THM as detailed in the Procedure – Installation (THM) ([page 48](#)).
6. **Install TDM** – Install the TDM as detailed in the Procedure – Installation (TDM) ([page 36](#)).
7. **Run SDT** – Run SDT to ensure all device features and functions operate as expected.



Environmental Compliance Requirements

All waste electrical and electronic equipment (WEEE), waste electronic components, waste batteries, and electronic waste residuals must be managed according to applicable laws and regulations. and H09117, "Conformance Standards for Environmentally Sound Management of Waste Electrical and Electronic Equipment (WEEE)," which is available at this link: <https://www.microsoft.com/en-pk/download/details.aspx?id=11691>
In case of questions, please contact AskECT@microsoft.com

