



**World's largest selling  
water purifier#**

\*Based on Unit shipment sales for 2013. Excludes pitchers and faucet mount systems sales and includes only in-home point-of-use drinking water treatment systems.



*Marvella*  
RO+UV



Pureit Marvella RO+UV with  
**Advance Alert System**



**instructions manual**



## **WELCOME TO THE PUREIT FAMILY**

### **Congratulations!**

We thank you for the trust you have shown in our product and we assure you that our product will live up to your expectations. Millions of users trust Pureit to provide safe water to their loved ones.

Our product is developed by experts and it is designed to give you water that is 'As Safe As Boiled Water™'. Pureit adheres to some of the toughest standards of leading institutions both in India and abroad.

If you need to get in touch with us for anything, please call us at 1860-210-1000.

We once again thank you for buying Pureit Marvella RO+UV and we look forward to a long and fruitful association with you.

## CONTENTS

Unique Features of Pureit Marvella RO+UV .....	03
Know your Pureit Marvella RO+UV .....	04
Technical Specifications of Pureit Marvella RO+UV Purifier .....	05
Pureit Marvella RO+UV's Unique Technology .....	06
Water-Flow Diagram and Electrical-Circuit Diagram .....	07
Installation and Important Instructions .....	08
Cleaning and Maintenance .....	12
Advance Alert System of Pureit Marvella RO+UV .....	22
Ordering SF, GKK-1 and GKK-2 .....	23
Frequently Asked Questions (FAQs) .....	24
Troubleshooting .....	26
Warranty Card and Details .....	27
Statement of Hindustan Unilever's Intellectual Property Rights .....	30

## UNIQUE FEATURES OF PUREIT MARVELLA RO+UV



### Advance Alert System

Alerts you 15 days\* before life of the Germkill Kit™ gets over



### Advanced 6-stage technology

Advanced 6-stage purification through RO+UV technology



### 100% RO and UV

All the water always passes through RO and then UV to completely remove all harmful chemicals like lead, arsenic and mercury so that you get safe and pure water always



### TDS Modulator

Adds minerals post purification to enhance the taste of water



### TDS removal up to 2000 ppm

Pureit Marvella RO+UV turns hard water upto 2000 ppm into soft and sweet water



### Large 10 litres storage tank

Pureit Marvella RO+UV has 10 litres of storage tank, so you can get purified water even when there is no electricity



### Advanced voltage fluctuation guard

This protects your purifier from sudden voltage fluctuation as high as 300 volts and also works in low voltages of up to 100 VAC



### Break resistant tap

Pureit Marvella RO+UV is equipped with break-resistant tap which is tested for up to 50000 times



### No Annual Maintenance Contract

Pay for maintenance only when needed

\* Advance Alert System will alert you 15 days before end of every 180 days (approximately) or 15 hours before completion of every 200 hours of pump running time, whichever is earlier. The purifier will communicate the alert only if the purifier is in a switched on condition during the scheduled alert time. Post the completion of the scheduled alert time, Auto Shut off™ of water will be activated automatically, even if the purifier is in a switched off condition.

## KNOW YOUR PUREIT MARVELLA RO+UV

- 1 Cleaning Solution Dispenser
- 2 Storage Tank Indicator
- 3 Pre Sediment Filter Indicator
- 4 GKK - 1 Life Indicator
- 5 GKK - 2 Life Indicator
- 6 Storage Tank
- 7 Tap
- 8 Sediment Filter Assembly
- 9 Inlet Water Tube
- 10 Ball Valve Assembly
- 11 Ball Valve
- 12 Waste Water Tube

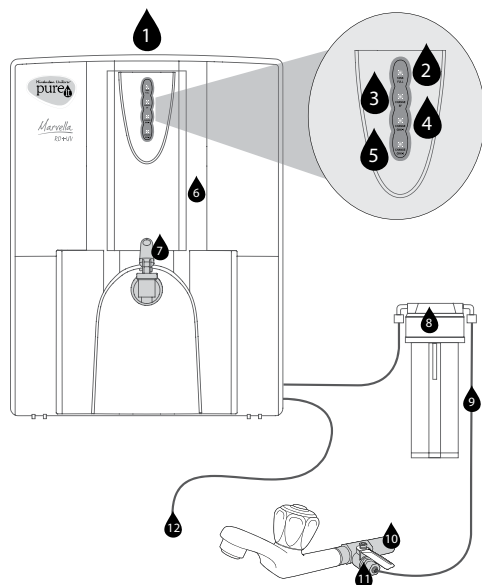

- 1 Tap
- 2 Indicators
- 3 Post-Carbon Sediment Filter
- 4 RO Membrane Housing
- 5 UV Reactor
- 6 Post-RO Carbon Filter\*
- 7 Pre-RO Carbon Filter
- 8 Pump
- 9 Low Pressure Switch
- 10 Solenoid Valve
- 11 Flow Restrictor
- 12 Control Circuit
- 13 Storage Tank
- 14 Pre-Sediment Filter
- 15 Waste Water Tube
- 16 Cleansing Solution Dispenser
- 17 Inlet Water Tube
- 18 TDS Modulator

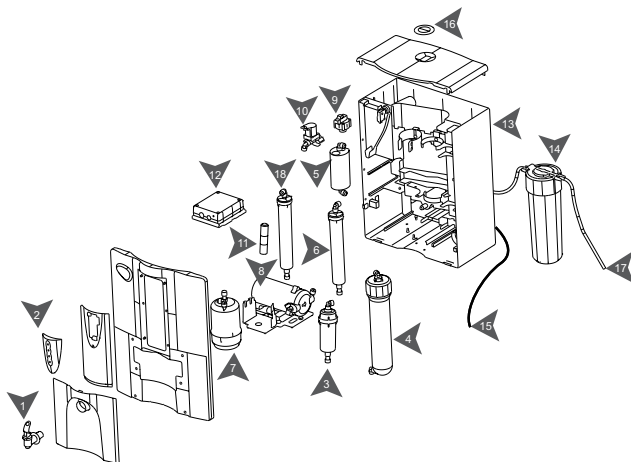

\* Post-RO Carbon Filter fitted in the device may need to be changed intermittently at extra cost in case you face smell issues.

## TECHNICAL SPECIFICATIONS OF PUREIT MARVELLA RO+UV PURIFIER#

Pureit Marvella RO+UV	
Height	488 mm
Width	360 mm
Depth	294 mm
Weight of 'Pureit Marvella RO+UV'	~ 8.3 kg
Flow Rate*	Approximately 9 – 12 litres per hour
Storage Tank Capacity	10 litres
6-Stage Purifying Technology	PP Melt Blown Pre-Sediment Filter, Pre-RO Carbon Filter, Post-Carbon Sediment Filter, Reverse Osmosis Membrane, UV Reactor and Post-RO Carbon Filter
Membrane type	Thin-film composite spiral wound
Pump type	Diaphragm pump, 24V dc
% Recovery*	Typically 25%
TDS Reduction**	90% (min.)
Input Water pH Range	6.5 – 8.5
Power Rating	48 Watts
Pressure Rating	5 – 30 PSI***
Rated Voltage	Rated Voltage 140 to 240 V a.c., 50/60 Hz
Material of Construction for Plastic Parts	Food safe, non-toxic, engineering grade plastics
Length of Power Adaptor	1.5 metres
Total Dissolved Solids	Up to 2000 mg/lit
Total Hardness	500 mg/lit (max.)
Iron	0.3 mg/lit (max.)
Turbidity	1 NTU (max.)

Germkill Kit™	
Material of Construction	Food safe, non-toxic, engineering-grade plastics
Pre-Sediment Filter	Pre-Sediment Filter – 1 No.
GKK - 1	Pre-Sediment Filter – 2 Nos.
	Pre-RO Carbon Filter – 1 Nos.
	Post-RO Carbon Filter – 1 No.
GKK - 2	TDS Modulator – 1 No.
	Pre-Sediment Filter – 2 Nos.
	Pre-RO Carbon Filter – 1 No.
	Post-Carbon Sediment Filter – 1 No.
Germkill Performance Standard	RO Membrane – 1 No.
	Post-RO Carbon Filter – 1 No.
	TDS Modulator – 1 No.
Germkill Performance Standard	Meets stringent international criteria for microbiologically safe drinking water – e.g., Environmental Protection Agency (EPA), USA

\* Permeate flow rate and recovery are based on standard test conditions and may vary depending on input water quality, TDS, pressure and life of Filter elements.

\*\* Input water quality and TDS content are important determinants of output water quality.

\*\*\* If input pressure exceeds 30 PSI, please install a company provided pressure reducing valve at an additional cost. If the pressure is lesser than 5 PSI than you need to buy 'Pressure enhancing pump' at an additional cost. Device should not be installed in a house where input pressure is greater than 60 psi.

# Technical specifications are subject to change or improvement without prior notice.

## PUREIT MARVELLA RO+UV'S UNIQUE TECHNOLOGY

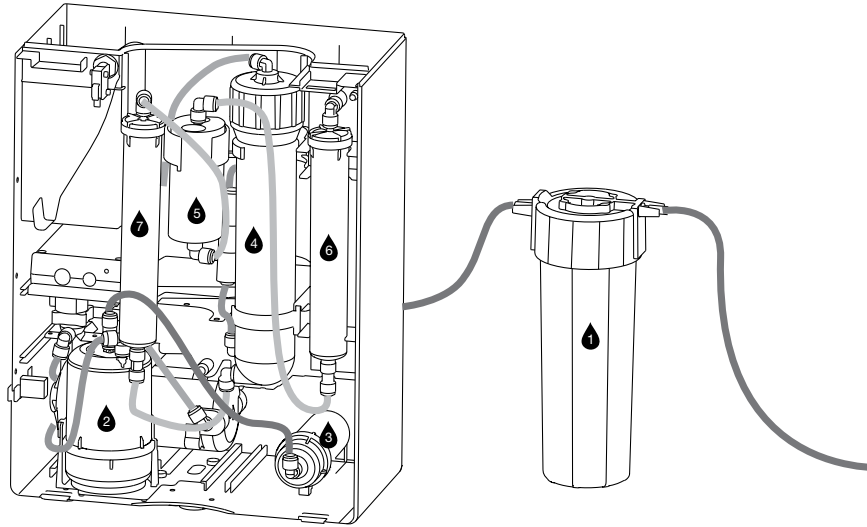

- 1 Pre-Sediment Filter**  
Removes fine and coarse particulate impurities/dirt and improves the life of the carbon Filter.
- 2 Pre-RO Carbon Filter**  
Removes chlorine and organic impurities like harmful pesticides. It also adsorbs bad taste and odour-causing organic compounds from water.
- 3 Post-Carbon Sediment Filter**  
Removes remaining fine and coarse particulate impurities/dirt and improves the life of RO Membrane.
- 4 RO Membrane**  
Removes dissolved salts, hardness, pesticides and heavy metals like arsenic, lead and mercury. It also removes microbial contaminants like bacteria, virus, protozoa and cysts.
- 5 UV Reactor**  
Acts as an additional stage of purification to further inactivate bacteria, virus and parasites to deliver safe water.
- 6 Post-RO Carbon Filter**  
Last level of purification acts as a polisher and enhances the taste of purified water.
- 7 TDS Modulator**  
Adds adequate quantities of essential minerals to the purified water.

## WATER-FLOW DIAGRAM

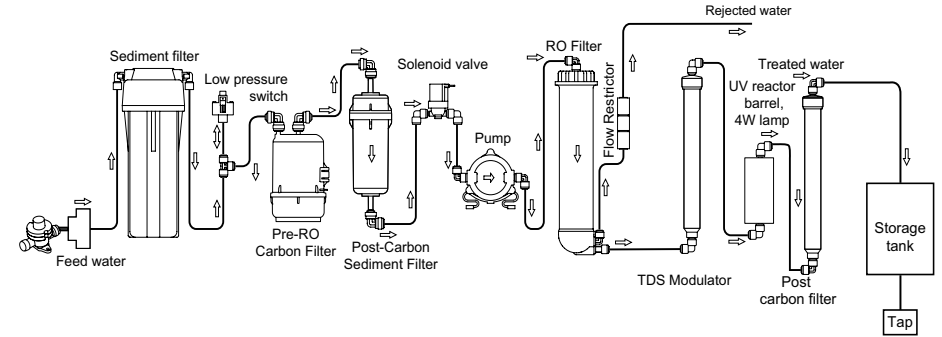

## ELECTRICAL-CIRCUIT DIAGRAM

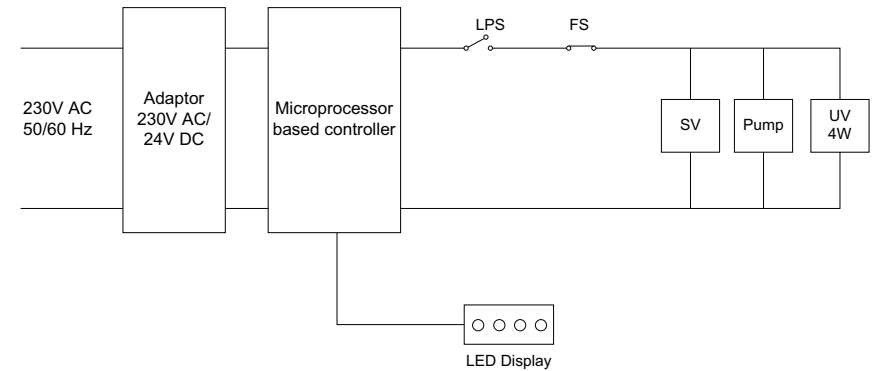

## INSTALLATION AND IMPORTANT INSTRUCTIONS

①

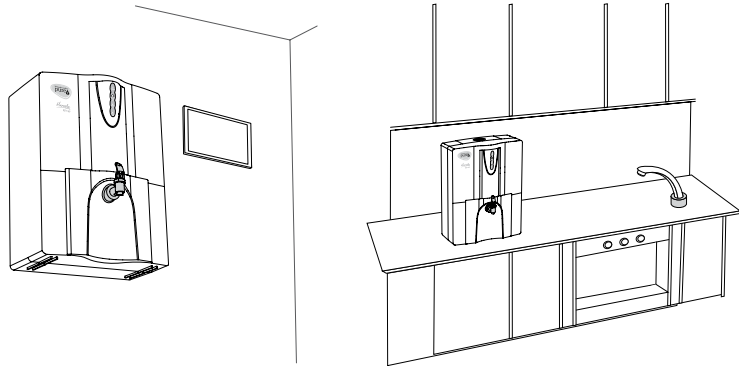

Pureit Marvella RO+UV must be installed on the wall or can be used as a table top purifier. Please follow the instructions given below while installing.

②



Ensure Pureit Marvella RO+UV is installed by a trained Pureit technician.

## INSTALLATION AND IMPORTANT INSTRUCTIONS

③

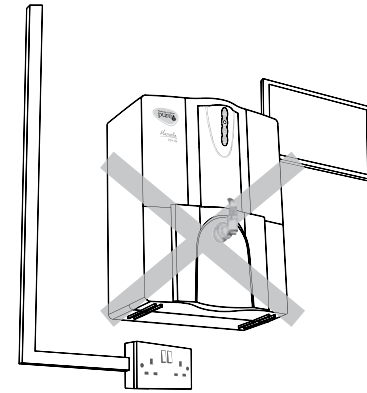

Ensure Pureit Marvella RO+UV is not installed above any electric socket. Ensure that you use the plug provided with the purifier and do not change it.

④

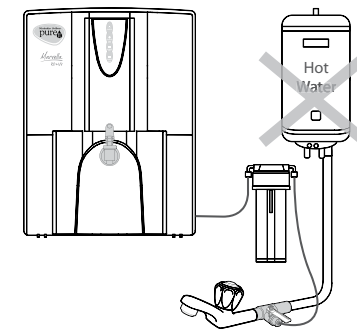

Pureit Marvella RO+UV should not be connected to any hot water tap.

## INSTALLATION AND IMPORTANT INSTRUCTIONS

5

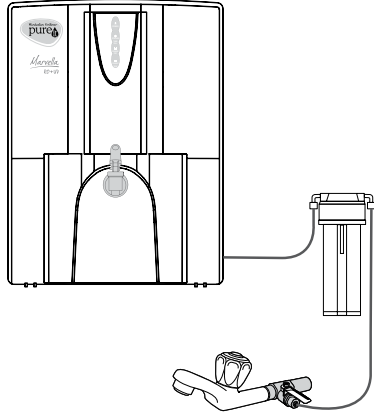

Ensure that the purifier is placed close to the plumbed inlet connection.  
Also, avoid sharp bends to the pipes.

6

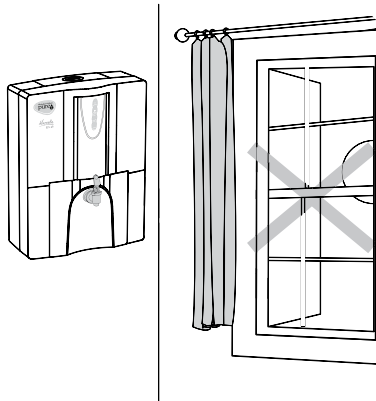

Install your Pureit Marvella RO+UV away from any direct sunlight, and ensure there is enough ventilation.

## INSTALLATION AND IMPORTANT INSTRUCTIONS

7

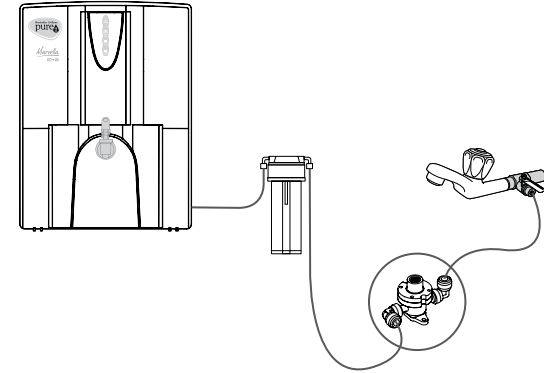

Ensure input pressure is more than 5 PSI and less than 30 PSI. If it is more than 30 PSI, you need to use 'Pressure reducing Valve' which must be bought at an additional cost. If the pressure is less than 5 PSI then you need to buy 'Pressure enhancing Pump' which can be bought at an additional cost. Ensure you buy them from the authorized service personnel of Pureit.

8

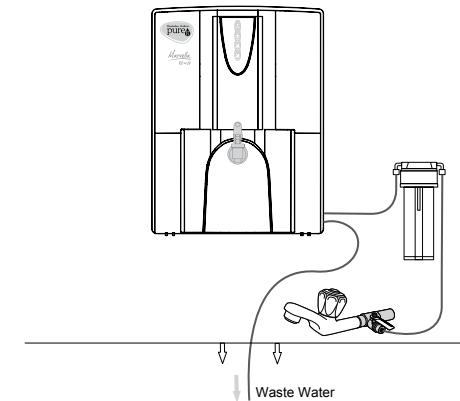

Ensure the waste water pipe is placed lower than the tap of the purifier.

9

The Post-RO Carbon Filter must be detached from the storage tank and flushed directly into the sink; before starting the regular usage. Discard the first cycle of water and do not use for drinking.

## CLEANING AND MAINTENANCE

①

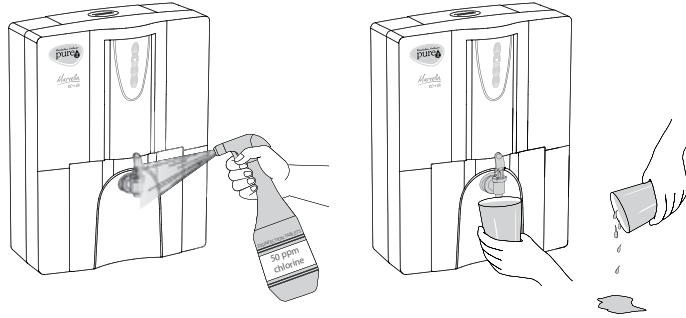

You can clean the tap by using disinfectants like bleach/ hypochlorite (50 ppm available chlorine). Discard 2 litres of water after cleaning the tap.

②

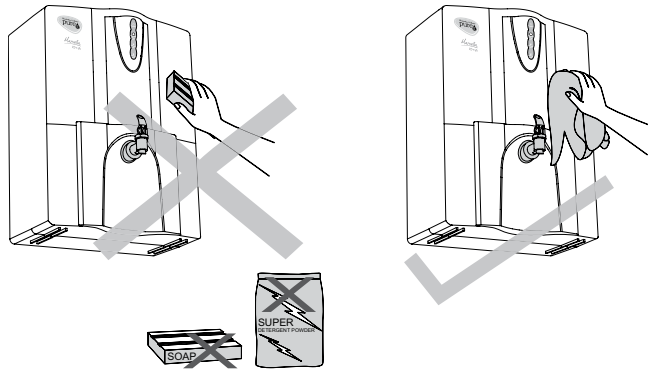

External portion of the purifier must be cleaned using wet cloth only. Do not use detergent or soap.

## CLEANING AND MAINTENANCE

③

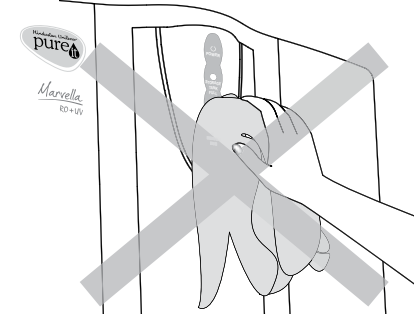

Do not extensively clean and rub the decorative parts and on the LED display panel as this might lead to scratches on the parts.

④

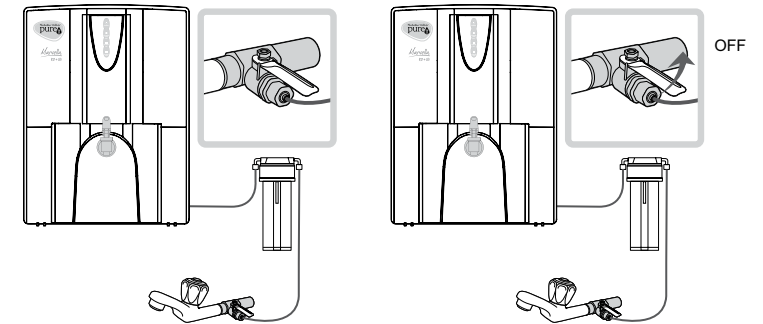

Always switch off the 'Ball Valve' and electrical power, if you are out of home for long duration.



## CLEANING AND MAINTENANCE

5

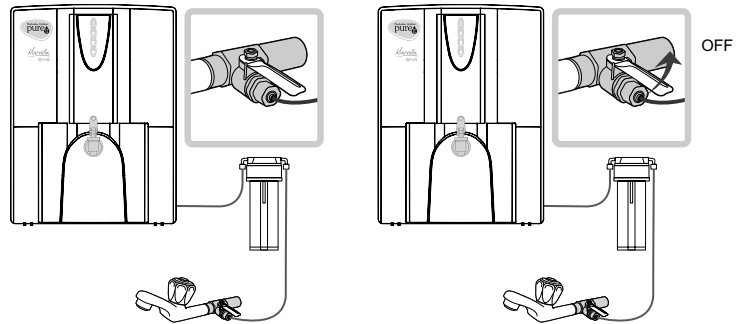

Turn off the Ball Valve and switch off the power if you notice any leakage from the purifier.

6

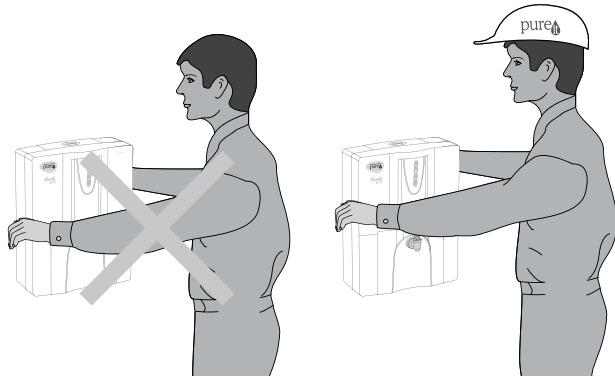

Do not try to open the purifier for cleaning or for any replacements. This can be done only by qualified company personnel or an authorized agent.

## CLEANING AND MAINTENANCE

7

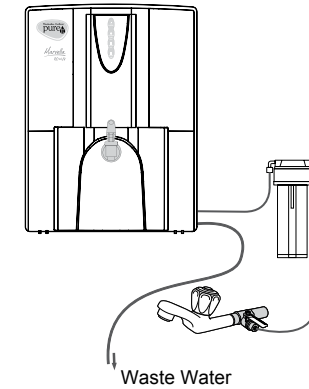

Do not drink the water from the waste water tube, as it is not suitable for drinking. However, you can use that water for gardening or for cleaning the floors.

8

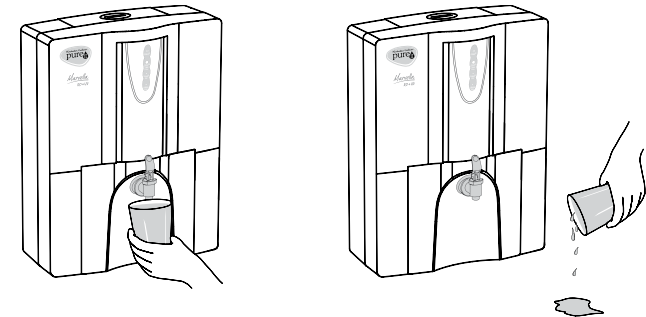

You should discard the water in the storage tank once in 15 days. Always drain the water in the storage tank if you have not used the purifier for more than 2 days.

## CLEANING AND MAINTENANCE

9

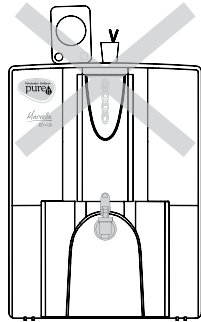

Do not put heavy or sharp objects on the purifier.

10

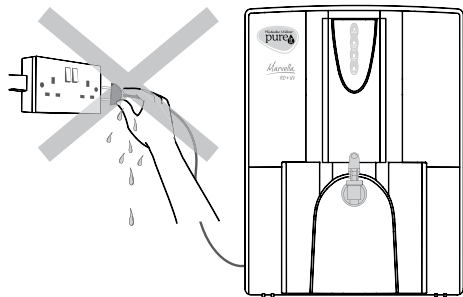

Do not plug or unplug the power cord with wet hands. Ensure that the plug isn't wet while plugging in or plugging out to avoid risks such as electrical shock or fire.

## CLEANING AND MAINTENANCE

11

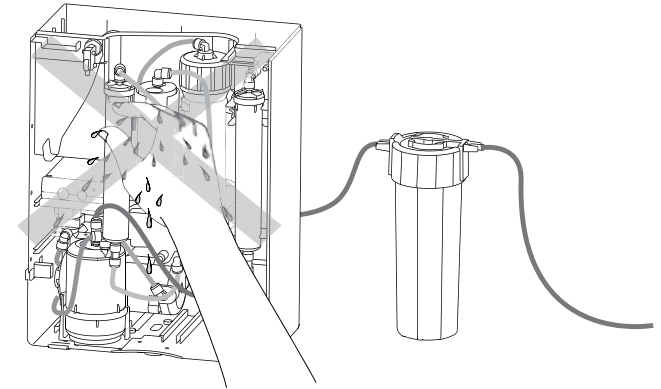

Never splash the filtration system with water while cleaning.

12

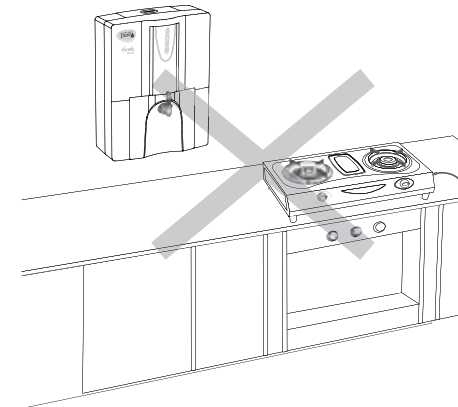

Keep the cord away from wiring conjunctions to avoid hazard. Never put the cord under rugs, near heat resistors, radiators, stoves or heaters.

## CLEANING AND MAINTENANCE

13

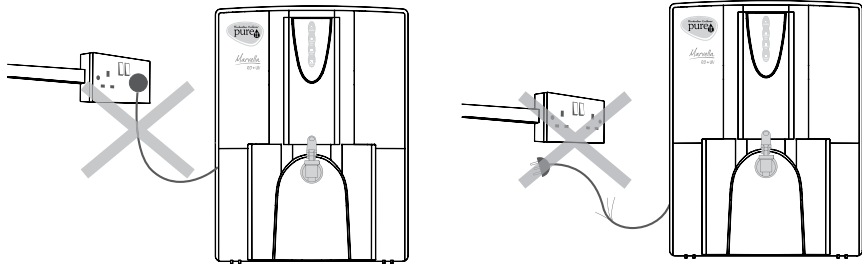

If the power cord is damaged, the power adapter must be replaced and not used.

14

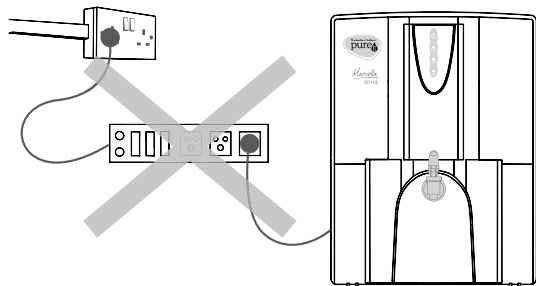

Avoid using an extension cord.

## CLEANING AND MAINTENANCE

15

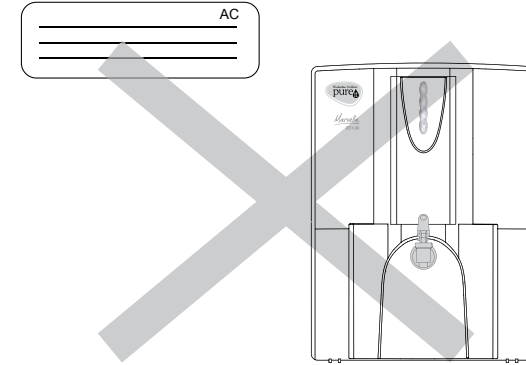

Do not install the purification unit where it could freeze.

16

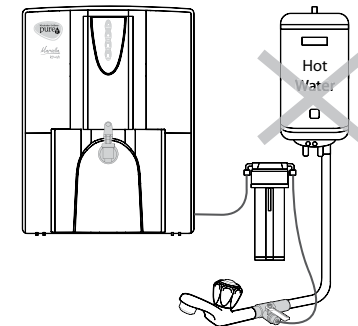

Do not run hot water over 45 °C through the purifier.

## CLEANING AND MAINTENANCE

17

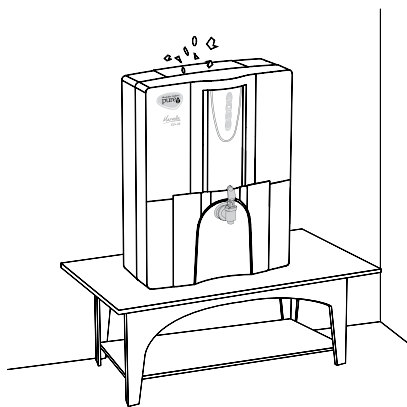

Do not allow any foreign or unexpected material (like dust/ants/insects/other pests) to enter into the storage tank. The filtered water in the storage tank may deteriorate in the process.

18

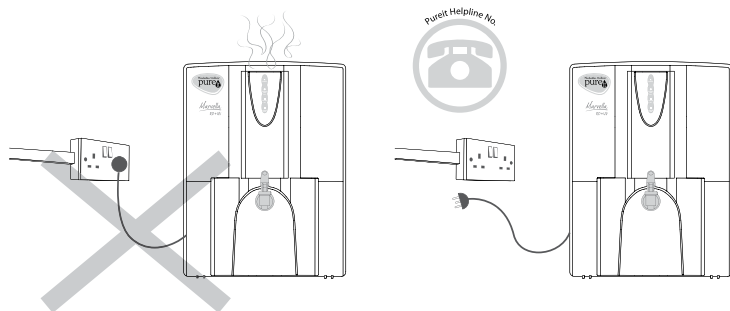

In case of any smoke or burning smell, remove the plug immediately and call the Pureit Helpline.

## CLEANING AND MAINTENANCE

19

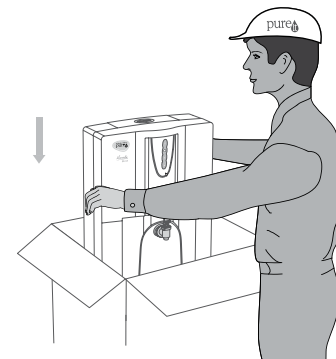

When shifting your house, get the purifier duly inspected and packed by the Pureit service technician. Remove water from the storage tank and properly pack the purifier in case of shifting.

20

You should clean the storage tank once a month by using the disinfectant which can be bought by calling our Pureit helpline number. To clean the tank just open the cleaning solution dispenser and put 1 ml of the solution (10–15 drops) into the storage tank. (Ensure the tank is full). Drain the entire tank after 10 minutes.

21

You should maintain good hygiene in the area around your water purifier. Ensure that this area is free of ants/insects/other pests.

22

In case UV lamp breaks, carefully sweep all the fragments, wipe the area with a wet towel, and dispose all the fragment including the used towel in a sealed plastic bag. Open windows to allow room to ventilate. Do not use vacuum. Hand over the bag to the service technician for proper disposal of the same when he visits to put a new UV lamp.

23

Please ensure that you switch off the power whenever you turn off the Ball Valve.

24

Please dispose the used consumables like Sediment Filters, Carbon Filter and Membranes along with the other household waste through the municipal disposal system.

25

Always rely only on the RED indicator to replace the consumables and Membrane. The RO Purity Lock is only an additional assurance of safety. In some cases the input water quality may prevent it from functioning.

26

You should only store water in the purifier and not use other bottles and containers. If you do so, water may get contaminated.

27

The point-of-use reverse osmosis drinking water treatment systems addressed by NSF-58 standard are designed to be used for the reduction of specific substances that may be present in drinking water supplies (public or private) which are considered to be microbiologically safe and are of known quality.

28

Do not use hot or boiling water in the purifier. Similarly do not use freezing cold water (less than 10 °C) in the purifier.

29

The output water may continue to have flora which are harmless and pose no health hazard to normal healthy adults and children.

## ADVANCE ALERT SYSTEM\* OF PUREIT MARVELLA RO+UV

Indicator	Indicator Status	Frequency of indication	Indication
Storage Tank Full	No light	N/A	Tank is not full
	Green	N/A	Tank is full
Change SF	Green	N/A	Pre-Sediment Filter is safe to use
	Blinking Red	165 days of clock time or 185 hours of pump running time, whichever is earlier, after device installation or GKK replacement	Life of the Pre-Sediment Filter will end soon. Please contact the Pureit helpline and get your Pre-Sediment Filter replaced*
	Solid Red	180 days of clock time or 200 hours of pump running time, whichever is earlier after device installation or GKK replacement	This indicates the life of the Pre-Sediment Filter is completed and must be replaced. At this point, Auto Shut Off™ shuts the water flow ensuring you don't drink unsafe water even by accident
Change GKK - 1	Green	N/A	GKK-1 is safe to use
	Blinking Red	After every 345 days of clock time or 385 hours of pump running time, whichever is earlier, after device installation or GKK-2 replacement	GKK-1 life will end soon. Please contact the Pureit helpline to replace your GKK-1
	Solid Red	After every 360 days of clock time or 400 <sup>#</sup> hours of pump running time, whichever is earlier, after device installation or GKK-2 replacement	GKK-1 life is completed and must be replaced. At this point, Auto Shut Off™ shuts the water flow ensuring you don't drink unsafe water even by accident
Change GKK - 2	Green	N/A	GKK-2 is safe to use
	Blinking Red	After every 705 days of clock time or 785 hours of pump running time, whichever is earlier, after device installation or previous GKK-2 replacement	GKK-2 life will end soon. Please contact the Pureit helpline to replace your GKK-2
	Solid Red	After every 720 days of clock time or 800 hours of pump running time, whichever is earlier, after device installation or previous GKK-2 replacement	GKK-2 life is completed and must be replaced. At this point, Auto Shut Off™ shuts the water flow ensuring you don't drink unsafe water even by accident



### ORDERING SF, GKK-1 AND GKK-2



**Phone**  
1860-210-1000



**Log in**  
[www.pureitwater.com](http://www.pureitwater.com)

In case of key electrical faults (UV, RO Pump, RO SV, booster pump) the 2nd, 3rd, and 4th LEDs will start blinking red and the device will stop purifying water.

During the initial start up of the device, the tank full LED will blink for max 15 min and then restore to normal operation thereafter.

<sup>#</sup> After every 400 hours of pump running time or 360 days of clock time, whichever is earlier, the respective Germkill Kit™ needs to be changed. Every 400 hours of pump running time typically gives 4000 litres of purified water under test conditions of 18 PSI input pressure, 450-500 ppm TDS and 25 °C temperature.

While the Germkill Kits and the Sediment Filter have a fixed replacement schedule, you might be required to change the SF in the interim depending on the quality of your input water.

\* There is a free Sediment Filter in your device which needs to be preserved to facilitate the above change. In case you misplace the free SF, then at the time of Sediment Filter change you will have to buy the same at extra cost.

## FAQs

### How does Pureit Marvella RO+UV purify water?

Pureit Marvella RO+UV has a 6-stage purification system which ensures you get water that is 'As Safe As Boiled Water™' and also removes excess total dissolved solids (TDS) to make your water tastier.

In the first stage, the water passes through the Pre-Sediment Filter which removes fine and coarse particulate impurities/dirt.

The second stage is the Pre-RO Carbon Filter that removes chlorine and organic impurities like harmful pesticides. It also adsorbs bad taste and odour-causing organic compounds from water.

The third stage is the Post-Carbon Sediment Filter which removes the remaining dirt.

Then the water passes through the RO Membrane at high pressure, with the help of an inbuilt pump. The RO removes dissolved salts, hardness, pesticides and heavy metals like arsenic, lead and mercury. It also removes microbial contaminants like bacteria, virus, protozoa and parasites.

Fifth stage is a UV reactor that acts as an additional stage of purification to further inactivate bacteria, virus and parasites to deliver safe water.

After UV Reactor, water passes through a TDS Modulator that adds adequate quantities of essential minerals to the water.

### What is the storage capacity of 'Pureit Marvella RO+UV'?

Pureit Marvella RO+UV has a storage tank capacity of 10 litres. The process of filling the storage tank is fully automatic and when you take water out of the tank, the purification process automatically starts and refills the storage tank.

### How much time it takes to purify water in 'Pureit Marvella RO+UV'?

Pureit Marvella RO+UV can purify water upto 9–12 litres per hour. However, the time taken to purify depends on the life of the Filters, the input water pressure, TDS and other impurities present in water.

### 'How will I get new consumables/Membranes replaced?

You need to call the Pureit Helpline and order for a Germkill Kit™. The Pureit Helpline specialist will visit your place and replace the Germkill Kit™ at a nominal cost.

### Why is the "Tank Full" indicator blinking when I switched on the purifier for the first time?

Pureit Marvella RO+UV has been designed in such a way that during the first time startup of the device, the "Tank Full" indicator will blink for 15 minutes (maximum) and then normalise for usage.

### The Advance Alert System™ did not give me 15 days warning before the purifier stopped working. Why is it so?

There may be several reasons for this.

While the Germkill Kits and the SF have fixed replacement schedules, depending on your input water quality the SF might need a replacement even before the purifier gives you an alert. In such cases, please contact Pureit helpline on 1860-210-1000 and get the SF replaced.

Also, Advance Alert System™ will alert you 15 days before end of every 180 days (approximately) or 15 hours before completion of every 200 hours of pump running time, whichever is earlier. The purifier will communicate the alert only if the purifier is in a switched on condition during the scheduled alert time. Post the completion of the scheduled alert time, Auto Shut off™ of water will be activated automatically, even if the purifier is in a switched off condition.

### Can I drink the first purification cycle of water from the purifier?

No, it is recommended to throw the first cycle of water that is filled in the storage tank when the new Pureit Marvella RO+UV purifier is installed, and also whenever the Germkill Kit™(s) are replaced.

### What should I do if there is no purified water in the storage tank?

In case there is no purified water in the storage tank then you need to first check whether the LED display shows RED in either "CHANGE GKK-1" or "CHANGE GKK-2". If it shows GREEN or is blinking RED and still there is no water supply then you can check whether the Ball Valve is closed or the power is off. If none of the above 3 cases are true, please call Pureit Helpline for help.

### Can I open and service my purifier?

It is not recommended to open and service device by an individual. Call our Pureit Helpline if you face any issue which requires servicing and opening the device.

### Can I use any type of water to purify through my Marvella RO+UV?

Pureit Marvella RO+UV will purify "potable" water for removal of hardness and other impurities to give you safe drinking water. If the input water has impurities normally not present in drinking water (high iron/turbidity/microbial contamination etc.) or water is from unknown source (river/lake/pond/borewell etc.) then suitable pretreatments may be required.

### Can the Pre-Sediment Filter or the other filter parts choke before the Advance Alert ?

While the Germkill Kits and the Sediment Filter have a fixed replacement schedule, you might be required to change the filters in the interim depending on the quality of your input water.

Should the tap flow rate be very less or if it is taking too long for the tank to fill, then please contact the Pureit Helpline at 1860-210-1000 to change the membranes. These extra visits will be chargeable as per T&C.

### Can I use the reject water?

It is not recommended to use the reject water for any kind of consumption (drinking or cooking). It can probably be used for gardening or cleaning floors.

### What should I do if any part of the purifier is broken?

Please call the Pureit Helpline. Our technicians will visit your house and will guide you on the repairs required. There will be a nominal visiting charge and you would need to buy the parts required.

### What should I do if there is a leakage from the purifier?

First switch off the Ball-Valve if you find any leakage from the purifier and turn off the power switch. Check for any visual improper fitment (like tap) and then call our Pureit Helpline and register a service request.

### How long the stored water in Pureit Marvella RO+UV can be used for drinking?

You can use stored water for 2 days. If it is not used for more than 2 days we advise you to discard that water, refill and then consume.

## TROUBLESHOOTING

### **The water from the purifier tastes unusual**

This might be because of one or more of the following reasons:

- a) The storage tank has not been cleaned for a long time –  
Please clean the storage tank after removing the water with a mild hypochlorite solution. The hypochlorite solution can be ordered by calling our Pureit Helpline.
- b) The water is stored for too long in the storage tank –  
Please drain the stored water and fill fresh water.
- c) The Filters or the Membranes need to be replaced/cleaned –  
Please replace or get them cleaned by calling the Pureit Helpline.

### **The purification is taking more time**

This might be because of one or more of the following reasons:

- a) The Ball Valve may not be opened fully – Please ensure the Ball Valve is open completely so that the water flow is not restricted.
- b) The temperature of input water might have dipped drastically.
- c) The Filters or the Membranes need to be replaced/cleaned –  
Please replace or get them cleaned by calling the Pureit Helpline.

### **The storage tank is not getting filled**

This might be because of one or more of the following reasons:

- a) Check if the Ball Valve is kept open.
- b) Check if either "Change SF" or "Change GKK-1" or "Change GKK-2" is RED.  
If yes then replace the Filters/Membranes.
- c) Check if there is any leakage from the purifier and if there is any leakage then call the Pureit Helpline.
- d) The Filters or the Membranes need to be replaced/cleaned –  
Please replace or get them cleaned by calling the Pureit Helpline.

#### DISPOSAL GUIDELINES

To prevent possible harm to the environment or human health from uncontrolled waste disposal, please separate electrical items in this product such as power supply adaptor, control circuits, LED panel, UV Tube and wiring from other types of waste and recycle them responsibly to promote sustainable use of material resources. Contact either the retailer where you purchased this product, or local government office for details of where and how these items can be taken for environmentally safe recycling.



## Warranty Card

### Pureit Marvella RO+UV Water Purifier Warranty Registration Card

Serial No. \_\_\_\_\_

Date of Purchase: \_\_\_\_\_

Purchaser's Name: \_\_\_\_\_

Telephone No. \_\_\_\_\_

Address: \_\_\_\_\_  
\_\_\_\_\_

Dealer's Name: \_\_\_\_\_

Address: \_\_\_\_\_  
\_\_\_\_\_

\_\_\_\_\_  
Dealer's Signature  
(with rubber stamp)

#### Note:

1. Please retain the bill of purchase.
2. Please quote Serial number, Model and Date of Purchase in all your correspondence.

## 'PUREIT MARVELLA RO+UV' WARRANTY DETAILS

### Product warranty

The 'Pureit Marvella RO+UV' guarantees that you will get 'As Safe As Boiled Water™' as described in 'Pureit Marvella RO+UV's Unique Technology' section as long as the 'Pureit Marvella RO+UV' is used in the manner specified in this manual.

1. The Consumables including the Sediment Filter, Carbon Filter, Post-Carbon Sediment Filter, RO Membrane and Post-RO Carbon Filter and Post-Carbon Sediment Filter will not be covered under warranty.
2. The warranty does not cover external booster pump, pressure reducing valve which is bought as an accessory to the purifier.
3. All other components including the electrical parts will have a 12-month warranty against the manufacturing defects.

This warranty is subject to the following conditions:

The customer will notify the company in writing or by calling the help line promptly if any defects are noticed and give the company or its authorised agent adequate opportunity to inspect, test and remedy them. For this the customer may have to deposit the 'Pureit Marvella RO+UV' if so required by the company, with the company's office/service centre/authorised dealer along with the original invoice, in the city where they are sold.

Inspection and test report of the company's office/service centre/authorised dealer will be final and binding under the warranty for determining defects, repairs/alterations required or carried out, or certifying working of the 'Pureit Marvella RO+UV' thereafter.

The company's obligation under this warranty shall be limited to repairing or providing replacement of parts, which are found to be defective.

The company or its authorised Pureit Helpline centre/licensed service provider reserves the right to retain any part(s) or component(s) replaced at its discretion, in the event of a defect being noticed in the equipment during the warranty period.

The company's liability under this warranty shall in no event, and under no circumstances, exceed the price paid by the customer.

This warranty is confined to the first purchaser of the product only and is not transferable.

In the event of repairs of any part/s of the 'Pureit Marvella RO+UV', this warranty will thereafter continue and remain in force only for the unexpired period of the warranty.

The warranty is issued at Mumbai, and courts at Mumbai shall have exclusive jurisdiction over matters covered or flowing from this warranty.

The company obligation is only for effective repairs of any defective part of the 'Pureit Marvella RO+UV', and not for 'Pureit Marvella RO+UV' replacement as such.

Repairs or replacements will be carried out either by the dealer from whom the device has been purchased or through a Company Pureit Helpline Centre, or the Authorised Licensed service provider with whom the device has been registered.

For units installed beyond the municipal limits of the jurisdiction of the Authorised licensed service provider or company Pureit Helpline centre, all expenses incurred in collecting the device(s) for part(s) thereof from the company's Pureit Helpline centre or licensed service centre, as well as expenses incurred in deputing of service personnel/technicians towards conveyance and other incidentals etc. will be borne by the customer.

The warranty is void if any repair work is carried out by persons other than those of the company, or its authorised dealers.

Any part(s) of the electrical and purifier system replaced by the company at its discretion shall be with a functionally operative part.

The concerned Pureit Helpline centre or Licensed service provider will advise the customer whether to effect the repair at site or at the Pureit Helpline centre.

## 'PUREIT MARVELLA RO+UV' WARRANTY DETAILS

Warranty does not cover accessories external to the equipment supplied by the dealer.

In case of repairs or replacement of any part/s of the unit, this warranty will thereafter continue and remain in force only for the unexpired period of the warranty. Replacement of parts would be purely at the discretion of HUL, the same part model shall be replaced and in the event such part model has been discontinued, it shall be replaced with the part model of price equivalent at the time of purchase.

In case of any damage to the product/customer abuse/repairs by unauthorized personnels/misuse detected by the authorized service center personnel, the warranty conditions are not applicable and repairs will be done subject to availability of parts and on a chargeable basis only.

This warranty shall not cover any consequential or resulting liability, damage or loss to property or life arising directly or indirectly out of any defect in the water purifier. The company's obligation under this warranty shall be limited to repair or providing replacement of defective parts only under the warranty period.

The warranty is not applicable in any of the following cases:

01. The completed warranty card is not presented to authorized service personnel at the time of service of the product.
02. The product is not operated according to instructions given in the operating instruction booklet.
03. The device is not installed in the proper procedure specified.
04. Any defect caused due to improper electrical circuit outside the device in the house or by any defective electrical supply.
05. Defects are caused by improper or reckless use, which shall be determined by the company personnel.
06. Any repair work is carried out by the persons other than authorized service personnel.
07. The damages caused by due to transportation or shifting is not covered by warranty.
08. Defects are due to causes beyond control like lightning, abnormal voltage, acts of god or while in transit or service center or purchasers residence. (normal voltage range specified 230 volts +/- 10% with 50Hz). Customer shall ensure that a stabilizer is installed in those areas where voltage is not available within the warranty range (230V +/- 10%). The stabilizer should be of any reputed manufacturer.
09. The warranty will automatically terminate after 12 months expiry of the warranty period even though the device may not be in use for any time during the warranty period for any reason.
10. Only courts in Mumbai will have the jurisdiction for settling any claims.
11. The serial number of the device or any part thereof is damaged, defaced, altered, obliterated, or tampered with or removal for any reason whatsoever.

This warranty is valid in India only.

Notwithstanding anything to the contrary contained in, or implied by this warranty:

The company's liability under this warranty shall be limited only to defects in the 'Pureit Marvella RO+UV' which occur under the conditions of normal operation of the 'Pureit Marvella RO+UV' and their proper and prescribed use as per this user manual. This warranty does not cover or extend to defects which are determined by the company or its authorised agents as occurring or resulting from or attributable to negligence, abuse, misuse, faulty care, operation or maintenance or repairs, alterations to the 'Pureit Marvella RO+UV' or any part thereof by others.

### General

For the purpose of this warranty, the following expressions shall have the following meanings respectively:

- 'The 'Pureit Marvella RO+UV' shall mean the 'Pureit Marvella RO+UV' described in the invoice.
- 'The customer' shall mean the purchaser of the 'Pureit Marvella RO+UV' from the company or the company's authorised dealer who is a party to the invoice.
- 'The company' shall mean Hindustan Unilever Limited.
- 'Invoice' shall mean the Invoice issued for the 'Pureit Marvella RO+UV' by the company or its authorised dealer to the customer describing the 'Pureit Marvella RO+UV' and indicating, inter alia, the total purchase price thereof, the name of the customer, and the place where the 'Pureit Marvella RO+UV' is to be delivered.
- 'User manual' shall mean the instructions for installation, use and maintenance contained in the leaflet published by the company, and delivered to the Customer at the time of sale of the 'Pureit Marvella RO+UV'.
- Visit the Pureit website for more detailed instructions on cleaning/maintenance of your purifier
- Warranty doesn't cover any damage/other issues arising out of ingress of external/foreign material (like dust, insects, ants, other pests) in the water purifier as it is the responsibility of the consumer to keep the area around the purifier clean and free of pests/dust.



## STATEMENT OF HINDUSTAN UNILEVER'S INTELLECTUAL PROPERTY RIGHTS

Products covered under Hindustan Unilever's intellectual property rights	
Pureit Marvella RO+UV	RO Purity Lock
Germkill Kit™	Advance Alert System
As Safe As Boiled Water™	Auto Shut-Off™
Germkill Life Indicator™	



Hindustan Unilever Limited

© HUL 2014