

Operating Instructions



Storage Electric Water Heater
Puro DX 10 L, 15 L & 25 L



HAVELLS

Dear Customer,

We congratulate you on choosing a **HAVELLS** Electric Water Heater, one of the highly prestigious brand in India. Meticulously designed, using only the highest quality materials and components, your electric water heater is designed to have many years of trouble free operation.

To enable your electric water heater to give you many years of perfect trouble free service, we recommend you to follow the advice contained in this Instruction manual very carefully.

Parts List: Puro DX

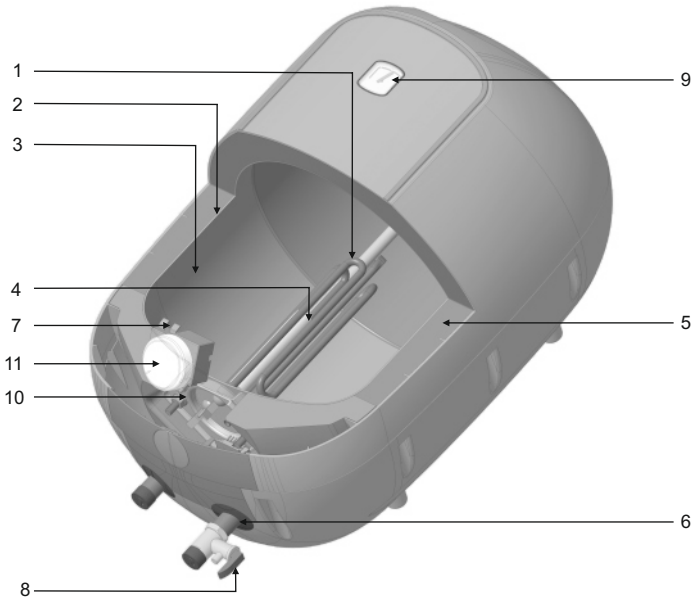

1. High quality incoloy 800 glass coated heating element
2. Heavy guage inner tank
3. Ferro glass coating layer
4. Heavy-Duty anode rod
5. Energy saving high density PUF insulation
6. Water tubes with whirlflow
7. Thermal cutout / Thermostat with adjustable temperature knob
8. Multifunctional safety valve
9. External temperature meter
10. 4 Bolt flange
11. Temperature sensing LED knob

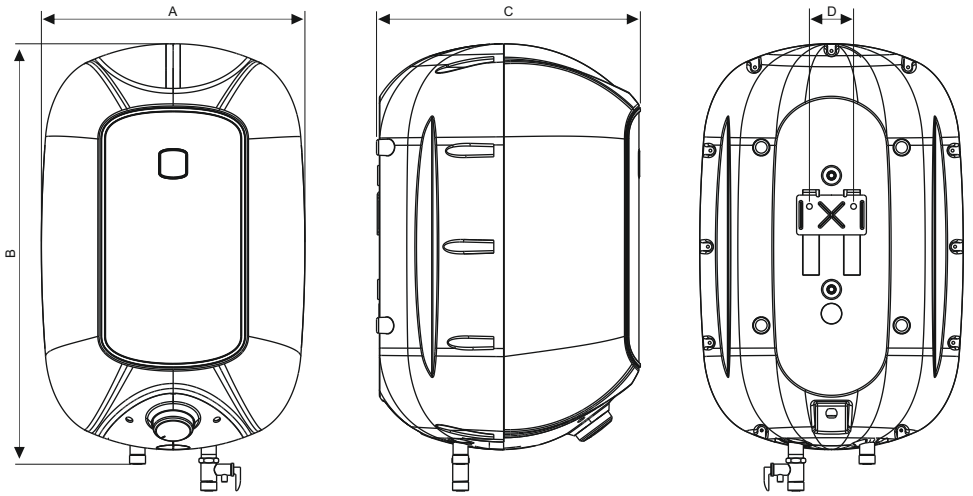

Model	A	B	C	D
Puro DX 10 L	318 mm	460 mm	304 mm	62 mm
Puro DX 15 L	329 mm	510 mm	330 mm	62 mm
Puro DX 25 L	370 mm	590 mm	370 mm	62 mm

*Note: All dimensions are in mm, dimensions tolerance ± 5 mm
 Dimensions in mm above refer to mechanical figures in this page.

Technical Specifications:

S. No.	Parameter	Puro DX		
1.	Rated Capacity in L	10 L	15 L	25 L
2.	Mounting	Vertical	Vertical	Vertical
3.	Rated Voltage in Volt & frequency in Hz	230 V, 50 Hz, 1 Phase, AC		
4.	Rated Power Input in W	2000 W		
5.	Rated Input Current in Ampere	8.7 A	8.7 A	8.7 A
6.	Max. Hot Water Output Temp. (°C)	75 °C	75 °C	75 °C
7.	Rated Pressure in MPa	0.8 MPa	0.8 MPa	0.8 MPa
8.	Standing Loss in kWh /24 h / 45 °C	0.365 kWh	0.419 kWh	0.511 kWh
9.	Reheating Time in Minutes to raise 50 °C	15 min	20 min	47 min
10.	Mixing Factor Maximum (%)	30%	30%	30%
11.	Weight of water heater in kg			
	- Empty	8 kg	8.7 kg	11.8 kg
	- Water Filled	18.2 kg	24.3 kg	36.6 kg
12.	Water Proof Degree	IP X 4	IP X 4	IP X 4
13.	Class of Appliance	Class I	Class I	Class I

WARNING:

The installer should review the contents of this manual along with the owner after completion of installation and the manual should be left with the owner and placed at a place close to the installation.

Key Features:



Feroglass

1. Feroglass Coated Tank with single Weld Line Design:
 - A. Made of Ultra thick superior quality steel.
 - B. Provides more corrosion resistance and anti-rust property compared to standard inner tank designs resulting longer life
 - C. Single weld line on the inner tank eliminates the risk of water leakage



Magnesium Anode

2. Heavy Duty Anode Rod Protects Tank From Corrosion:

With steel core, magnesium anode rod protects enamelled tank from rust and corrosion.



Incoloy Element

3. Incoloy Heating Element:

Incoloy 800 Coated Heating Element offers superior heating performance with its excellent resistance to both oxidation & carbonization at high temp. setting. Also resists erosion against most extreme and hard water conditions thus extending life span of heating element with minimum energy loss.



Polyurethane Insulation

4. Energy Saving High Density Puf Insulation :

CFC free thicker PUF insulation offers complete protection against radiant heat loss.



Whirl flow Technology

5. Water Tubes with Whirl Flow :

The whirl flow ensures no immediate direct contact between cold and hot water for a faster heating and maximum energy saving effect.



Thermal Cut out

6. Thermal Cut Out :

Cuts off electric power to guarantee safety , in case the water temp. exceeds the highest temp. Beyond Pre-set of the thermostat.



Multi functional Valve

7. Multifunctional Safety Valve (MFV) :

The MFV used with this unit is a unique safety valve. This has four functions

1. Pressure Release Valve (PRV)
2. Non return Valve (NRV)
3. Vacuum Release Valve (VRV)
4. Drain Device



Temperature Sensing LED knob

8. Adjustable Temp. Knob with Thermostat :

Allows a manual setting for heating of water between ambient temperature to 75 °C. with temperature indication by LED glow transition.



4 Bolt Flange

9. 4 Bolt Flange:

Provides an easier way for product maintenance.



Thermometer Disp

10. Temperature gauge

Generally indicates the heating of water and related temperature.



11. Shock Safe Plug

India's first integrated shock safe plug is designed to prevent injury to humans due to electric shocks, the plug will cut off the power immediately in case of any current leakage.

Safety Devices:

Havells Water Heater is built-in with a host of Safety Devices to ensure your safety at all times. The operation of these device are described below:

A. Thermostat

Capillary type thermostat: This device “cut-off” and “cut-in” the power supply between a narrow band of temperature range. The indicator lamp provided with this circuit glow and un-glow during cut-in and cut-off. This shows the proper working of the thermostat. This device is provided with an adjustable knob to set the desired water temperature.

B. Thermal Cutout

A non-self resetting thermal cutout is provided as a safety device. When the thermostat fails to function, this cut-off the power at 95 °C ± 5°C.

The thermal cutout has to be manually reset before the heater can start operating again.

C. Earth Leakage Circuit Breaker(ELCB)*

This water heater is equipped with an earth leakage circuit breaker(ELCB) which will cut-off the power immediately in case of any current leakage. This will ensure protection against electric shock in case of current leakage. In order to ensure that the ELCB is working normally, press the 'Testing' button on the device. If ELCB cuts off the power to the heater, it means that it is working properly. After testing, please reset button to restore normal functioning of the heater. It is advisable to periodically repeat this test to verify the functioning of the ELCB.

D. Multi Function Valve (MFV)

1. This valve prevents the built-up of excessive pressure within the water heater by releasing water from the drain.
 2. It also acts as a non-return valve to avoid the return of water from the water heater back to supply, thereby prevent the dry heating.
 3. It acts as an expansion valve to allow the hot water expansion during heating which flows back through drain.
 4. Customer can ensure proper working of the MFV by cleaning of salt deposits, by lifting the drain lever up. Customer can drain out the water from tank in case of prolonged non-use of water heater.
-

Installation & Safety:

- A. Always use services of qualified plumber/electrician to install this unit.
- B. For easy installation and servicing, enough space should be provided around this unit (5 cm from ceiling, 50 cm from sides & minimum 1.8 m from ground).
- C. Ensure following tools and accessories are made available before installation of this unit (not provided by company).
 1. Drilling machine with concrete drill bit sets, spanner and tool kit.
 2. Two numbers of metal flexible pipes.
 3. PVC pipe for drain

Preparation of Wall Structure

For installation of this unit, you need to prepare the wall suitably.

A. In case of hollow brick walls.

1. Dig up sufficient space to accommodate the wall mounting bracket (bracket supplied with water heater) of minimum depth 10 cm
2. Fill up the complete dig up space with cement concrete.
3. Ensure cement concrete is properly cured/set.
4. Then, the wall bracket can be fixed with the help of bolts provided along with the unit.

B. In case of solid walls

Follow process as below :

1. Drill hole in wall as shown Picture 1.
2. Insert the nut/bolt assembly in drilled hole, take out the bolt (as shown) Picture 1.
3. Fix the wall plate with the bolt and washer by testing testing till the wall plate is firmly fixed, in order to carry the weight of water heater safely (with water).

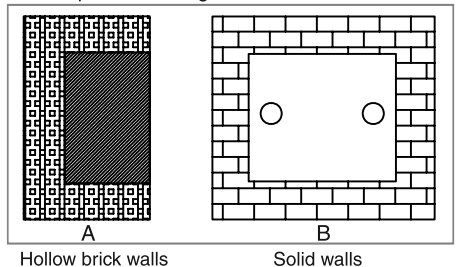

Hollow brick walls

Solid walls

Mounting

Now, the water heater can be hooked on the wall bracket.

1. After hooking on bracket, tug downward the water heater and ensure both fingers of bracket are properly seated in the mounting slot.

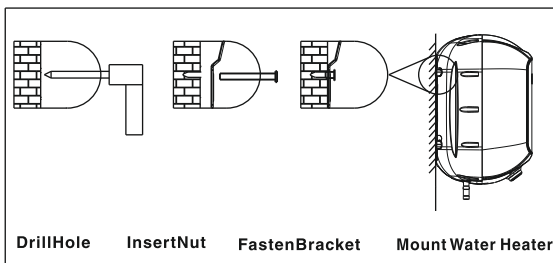

Picture 1

2. Do not install in the area of direct sunlight and water splashes.

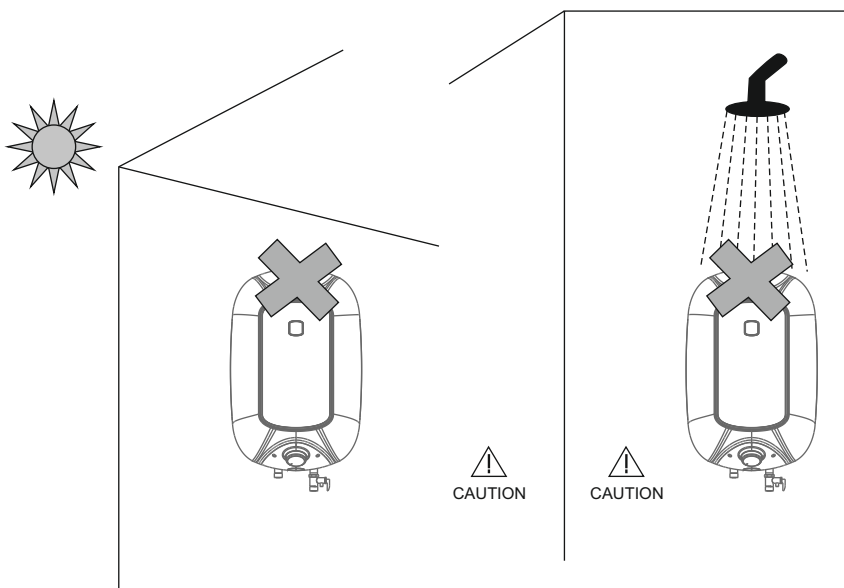

Picture-2

Water Connections

CAUTION

- A. Do not connect the inlet directly to water lifting pump.
- B. Do Not SWITCH ON water Heater without water filled in tank.
1. In case inlet water pressure is more than 0.8 MPa or water pressure head 80 metre, install the dead weight valve before inlet as shown in Picture 2 (not provided with this unit).
2. Minimum height between the water heater and water supply tank should be at least 1 metre.
3. For connecting the inlet & outlet between water heater and bathroom fittings, use metal flexible pipe having plastic nut / plastic adapter.
4. Cold water inlet is marked blue and hot water outlet is marked with red.
5. First, fix the multifunction valve (MFV) to inlet of water heater.
6. Connect cold water inlet to other end of MFV with metal flexible pipe having plastic nut / plastic adapter.
7. Open inlet water tap and allow the water to fill in the water heater. Make sure that the water starts flowing from outlet of water heater.
8. Connect the outlet with metal flexible pipe having plastic nut / plastic adapter, to hot water outlet point of bath fitting. Open the tap & valve and check the water is flowing through the hot water tap.
9. Connect MFV with PVC pipe for drain see Picture 3.

⚠ CAUTION

Ensure no leakage of water through inlet and outlet joints.

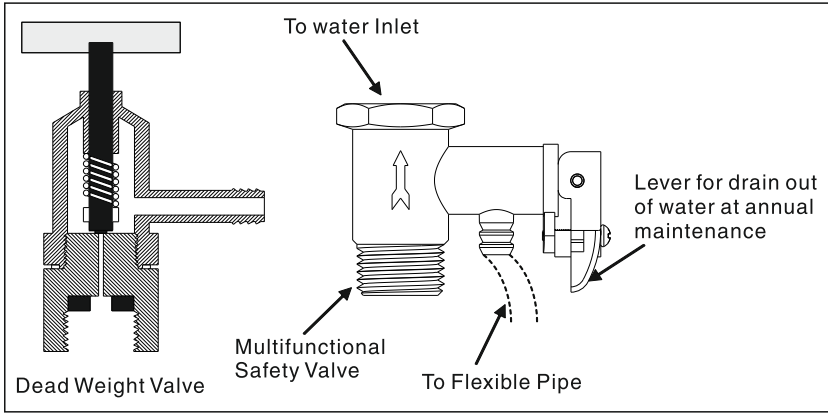

Picture 2

Picture 3

Electrical Connections

1. This unit is provided with all internal connections/wiring made in the factory itself.
2. The water heater is provided with a supply cord, with an in-built ELCB and a 3 pin plug top of 16 A
3. Make sure that the electrical contact of 3-pins plug and switch is secure with proper earthing.
4. To energize water heater, plug in the 3-pin in socket for electric supply.
5. C 16 A Double Pole MCB or 16 A fuse must be used as a back up protection for overload.
6. To ensure proper functioning, use test button in the Shock safe plug at least once a month.
7. Shock safe plug does not eliminate the risk of electric shock but limits duration of passage of current through human body for such a short time, probabilities of a lethal effect are reduced to a minimum.
8. IEC: 61540 recommend that shock safe plug should not be considered as a sole means of protection it is essential to provide proper earthing and all parts of the system should be properly insulated.

Internal Wiring Diagram -

The schematic diagram shows the internal wiring.

Make sure that the Water Heater is switched off and plugged-off from electrical supply before opening the Inspection cover. Follow the Internal wiring connections as shown in the diagram while carrying out the maintenance.

INTERNAL WIRING DIAGRAM

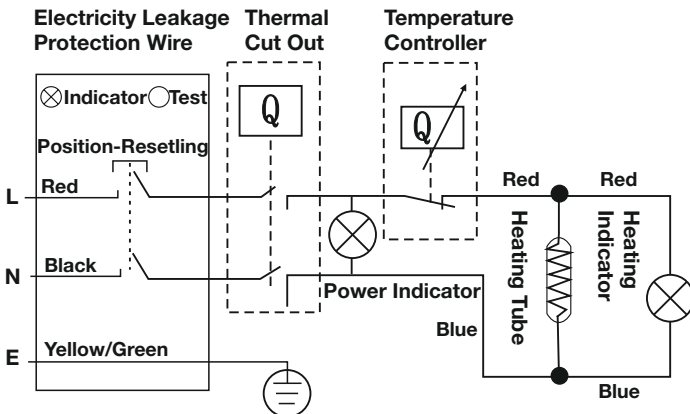

Operation of Water Heater:

A. Using the heater for the first time :

1. Do not switch "ON" before filling the heater with water.
2. Leave the hot water tap open. Now fill the heater by opening the control valve at the inlet.
3. When the heater is full, water will start flowing through the hot water tap. Close the hot water tap.
4. Now the heater will always have water inside. Water drawn will be replaced by water from the over head tank.
5. Always keep the inlet control valve open.
6. Now switch "ON" the power supply to the heater.

B. Using the heater regularly :

1. Always keep the inlet valve open so that water drawn from the hot water tap is automatically replaced from the mains.
2. When the water reaches the required temperature the thermostat will cut-off the power supply automatically.
3. The thermostat setting can be changed by the user to suit outlet water temperature. (DO NOT TAMPER THE SETTING FREQUENTLY)
4. Lowering the setting of the thermostat will give a lower hot water temperature; increasing the setting will give a higher hot water temperature.
5. Initially it may take a long time for the water to get hot, it is recommended to switch "ON" the water heater at least an hour before you want to use it.
6. If you require hot water early in the morning, switch "ON" previous night itself, thermostat would cut-off the power automatically, when the water reaches the set temperature.
7. The heater can also be kept "ON" always, if required since the heater is completely insulated, the water will remain hot. The thermostat will cut-in and cut-off automatically to keep the water at constant temperature. In this way you can always get hot water.

Maintenance & Cleaning:

1. To benefit from the highest standards of service and to ensure your guarantee remains in focus, please always contact HAVELLS approved dealer or HAVELLS Authorised Franchise
2. Always keep the inlet control valve open.
3. Never switch "ON" the water heater without water in the heater. It will damage the heating element.
4. Check condition of metal flexible pipe at-least once in a year. If found damaged replace with new pipes.
5. Check the condition of power supply cord for "No Damages". Replace it by an authentic supply cord in case of damage
6. To increase the life of heating element, de-scaling should be done periodically with the assistance of the nearest authorized service center.

Knob Glow Color : Blue	Heating
Knob Glow Color : Amber	Heated to Set Temperature

If the water heater is not going to be used for a long time,

- a. Plug Off the power supply,
 - b. Stop Inlet water supply
 - c. Unscrew the drain lever, lift the lever upward to remove the water through drain system provided in MFV.
7. During reuse of water heater
 - a. Ensure Drain Plug lever is reset and screwed
 - b. Open Inlet Valve and fill the water heater till the clean water flows from outlet tap.
 - c. Plug-in the power supply to heat the water
 8. Periodically check the MFV to ensure that it is in operating condition. The MFV should be operated regularly to remove salt deposits and to verify that it is not blocked.
 9. Check proper functioning of the safety valve in every two months by opening and closing the test lever.
 10. The heating element should be checked every year for "No Scale Formation" caused by impurities in the water supply.
 11. We recommend to check Magnesium anode rod in every year & once it has been used up over 60%, the Magnesium anode should be replaced with a new one.

For cleaning the element or replacing the anode use the following procedure :

1. Switch off the electric supply to the water heater.
2. Open the hot water taps until the hot water is removed completely.
3. Close cold water supply.
4. Drain the cold water from tank through MFV drain pipe by lifting the drain lever. Remove flexible pipe.
5. Remove the water heater from the hanger hook, after water heater is emptied
6. Remove the inspection cover from bottom , unscrew the heating assembly flange.
7. Clean the container and the heating element assembly to remove scale formation, by using a suitable acid or by gently scraping the scale. Check the heating element surface after cleaning for "No Surface Damage"
8. Replace Magnesium anode in case it is worn out .
9. Remount the heating assembly flange. Ensure the Internal wiring connection are made as per the wiring diagram shown in the manual.
10. Hang the water heater on the mounting bracket/ hook provided on the wall. Move the water heater down-ward to ensure that it is seated on bracket properly.
11. Open cold water supply until water flows without interruption from outlet valve.
12. Close the outlet valve and check for "No eventual leakage" around the flange and water connections.
13. When there is no leakage, then switch on electric supply.

DO'S

1. The gate valve at the inlet should always be kept open.
2. To minimize scaling of heating element & the tank, (which takes place rapidly in areas of hard water), drain the water from heater unit periodically. However get this done through a qualified technician / plumber only
3. Always get the water heater serviced once in a year from a Havells authorized service representative
4. Use genuine spares when spares placement is necessary.
5. Switch OFF the power supply to the unit & drain out the water when not in use for a longer period of time. This prevents scaling of the element.
6. In case both the lamps do not glow, do not start the unit by resetting the thermal cutout. Instead contact the nearest customer care centre.

DON'TS

1. Safety devices like safety valve, thermostat, thermal cut-out etc are pre-set from factory & sensitive devices. Do not tamper with them, this could be hazardous.
2. Do not switch ON the heater till it is completely filled with water.
3. In case you observe any abnormality of operation, immediately switch OFF the main power supply to the unit and contact the nearest customer care centre.
4. Never install a pressure reducer valve at the inlet.

WARRANTY

This Water Heater carries 7 years warranty for Inner Container, 4 year warranty on Heating Element, 1 year warranty on Shock safe plug and 2 Year comprehensive warranty on other electrical components from the date of purchase against manufacturing defects. Free repair will be provided under the warranty period when the Water Heater is returned to our Service Centre, freight and cartage paid.

This warranty only applies if -

- a) The water heater has been installed as per instruction manual.
- b) Maintenance has been carried out as instructed.
- c) Safety valves and anodes have been kept in right working condition.

The warranty is void if -

- a) The tank has been damaged by external causes.
- b) Damages due to misuse, accident, negligence, un-authorized repair or alteration or modifications or incorrect use of the water heater & normal wear & tear.
- c) The product is installed in the area of direct sunlight and water splashes.
- d) Warranty Void if MFV is not Installed with water heater.

Please preserve this warranty card along with paid bill/invoice from the dealer while making purchase. These documents must be presented to the service centre or to the dealer to avail this warranty.

Whenever some part is to be replaced get only genuine spares from our dealer. If there is any difficulty, please contact our service centre or customer care cell.

Actual products may vary in colour, design, description and colour combination etc.
Although every effort has been made to ensure accuracy in the compilation of the technical detail within this publication.
Specifications & performance data are constantly changing.

Copyright Subsists. Imitation of trade dress, graphics and color scheme of this document is a punishable offence.
Figure and Drawings are for illustrative purpose only.

Customer Name : Model No. :

Serial No. :

Invoice No. :

Date of Purchase :

Dealer`s Name, Address :

Dealer`s Seal & Signature

Customer Care Record

Date	Description of Complaint	Guarantee Yes/No	Remarks

Notes :



HAVELLS

Havells India Ltd.

QRG Towers, 2D, Sector -126,
Expressway, Noida - 201304 (UP) India, Ph. +91-120-3331000,
E-mail: marketing@havells.com, www.havells.com

Consumer Care No.:

1800 11 0303, 1800 103 1313 (All Connections), 011-4166 0303 (Landline)

Join us on Facebook at www.facebook.com/havells

and share your ways to save the planet!

CIN - L31900DL1983PLC016304.