

Original instructions

World Leader in Air Cooling



#

Certifications may vary from model to model.

Owner's Manual & Warranty Card

FOR SERVICE (INDIA)

 symphonylimited.com/service

OR

 <name, city, pincode, serial no.>
to **09510070111**

OR

 **07930130111**
give pincode, mobile no. & serial no.

Use any one of the above to register service request

WARRANTY REGISTRATION

Warranty will be applicable if registered within 10 days of purchase.

 symphonylimited.com/warranty

OR

 <sym, name, city, pincode, serial no.> to **09510180111**

Before use of this product please read and preserve these important instructions.

natural cooling

Symphony[®]

www.symphonylimited.com

How to install and operate Symphony Cooler

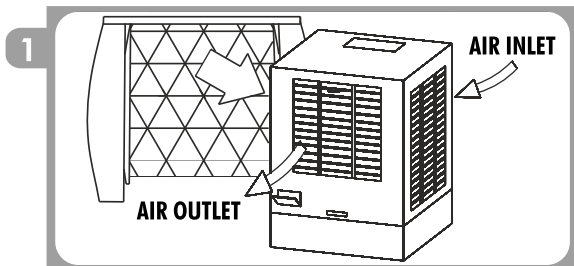

Take the cooler out from carton, Remove all protective covers. Place the cooler in front of an open window or install in a window for effective cooling. Selected Models can also be placed on trolleys. Do not use cooler in a closed room.

Ensure power supply is as specified for the cooler. There should not be any spikes in supply voltage. For operating on inverter, the cooler needs to be connected to only sine-wave inverter of appropriate rating.

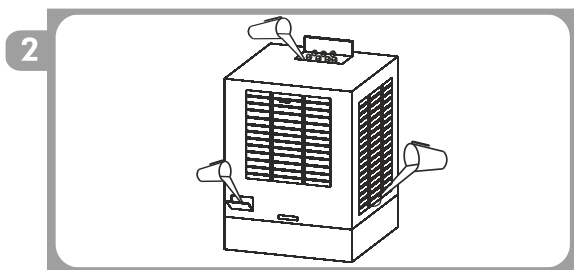

Disconnect the power cord while filling the water. As per the provision in your model, pour water by lifting the lid on top inlet or through front inlet or through spout at the back. You may also add ice cubes for faster cooling. Water can be poured up to the highest point (or F) of the water level indicator. You may keep a small container below over flow hole, to avoid spillage of water on your floor/carpet. For longer life of pump, always operate it with sufficient water in the tank.

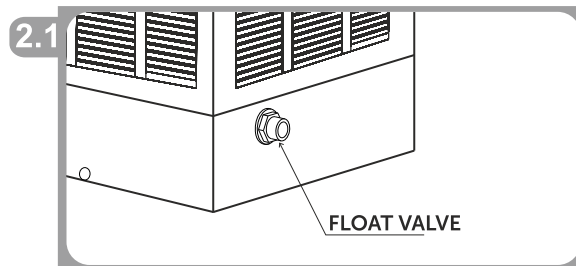

Float valve facility is available in Selected Models. Make provision for automatic water filling to the cooler. Ensure proper connection of water inlet pipe into the float valve to avoid leakage.

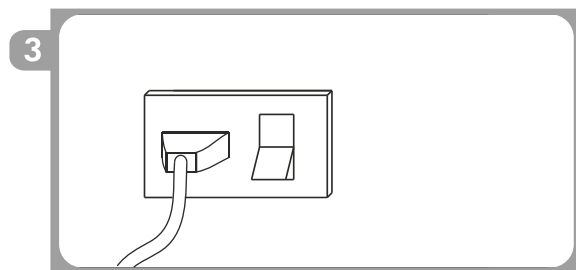

Plug in to power source and switch on.

How to install and operate product

4

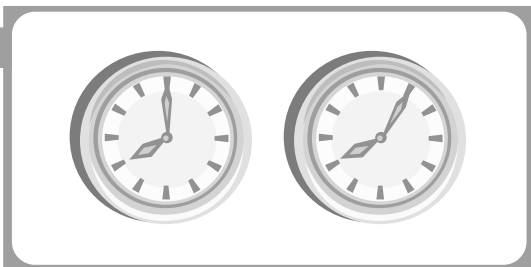

Switch on the pump of the cooler by putting the control knob in cool position but keeping the airflow control in OFF position. Wait for 5 minutes for the pad to get wet properly.*

5

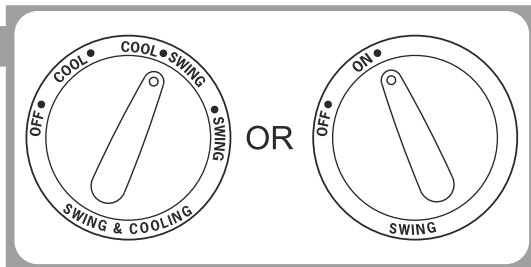

Set controls as desired.

6

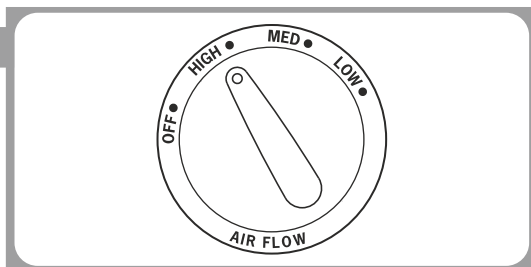

For maximum air and cooling turn the air flow control to " High "

* Not applicable to Window 51, Kaizen Jr., Sumo Jr., Storm 70i & Storm 100i model

7

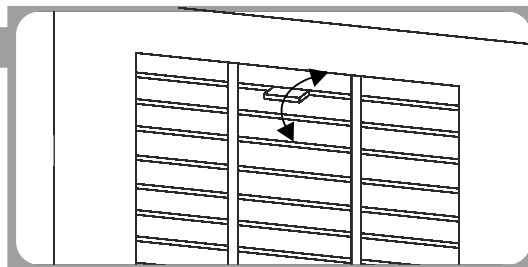

Adjust horizontal louver manually as desired.

8

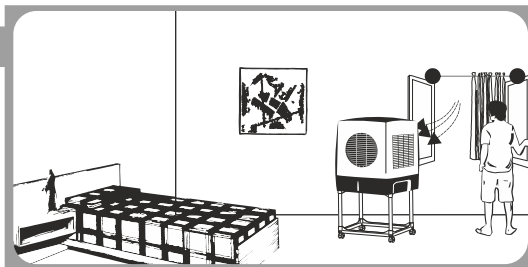

Keep the doors & windows open for optimum cooling performance. Always keep the cooler in front of an open window.

9

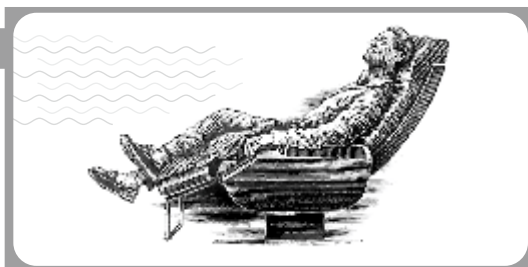

Sit back and enjoy.

How to operate Remote Control models - Storm 100 i & 70i

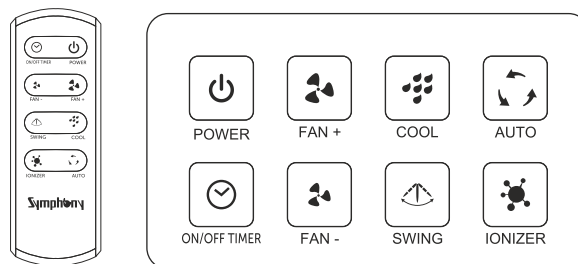

Remote Control & Control Panel may vary from model to model

1. POWER [⏻]: Power On and OFF
2. ON/OFF TIMER [🕒]:
ON TIMER : To set the ON timer, switch on the power supply then press the power button. ON timer icon in LCD will blink for 10 seconds, press the timer button in this duration and set the desired ON time. ON time can be set in intervals of 30 minutes, the set time will be displayed.
OFF TIMER : This will work when the cooler is running. You can set the OFF time in intervals of 30 minutes by pressing the timer button. Each press will increase the OFF time by 30 minutes up to 12 hours.
3. COOL [❄️]: Press the button to switch ON/OFF the pump. Cool Icon will appear on LCD when switched On. The Pump will start only when sufficient water is in the tank, this will be indicated by water symbol displayed on LCD. Pump will not start if the water level is low and this will be indicated by a buzzer for 5 seconds and water symbol on LCD will blink.
4. FAN +/- [🌀]: Fan+ will increase the speed by pressing button each time from any speed between 1 to 8 level & similarly Fan- will decrease the Fan speed
5. SWING [↔️]: Press button to switch on/off the swing function.
6. AUTO [🌀]: Auto function - The speed varies randomly to give the feel of natural breeze
7. IONIZER [⚡]: Ionizer function - ON and OFF (in selected models / optional)
8. This cooler must be moved only by properly holding the handle (given on top)

General: LCD background will turn off after 30 seconds and will re-appear while pressing any function keys

How to operate Remote Control models - Hi Cool i, DiET i Range, Winter i, Ninja i, Ice Cube i & other models

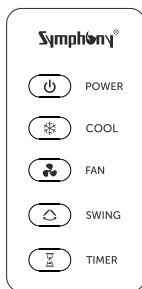

Remote Control*

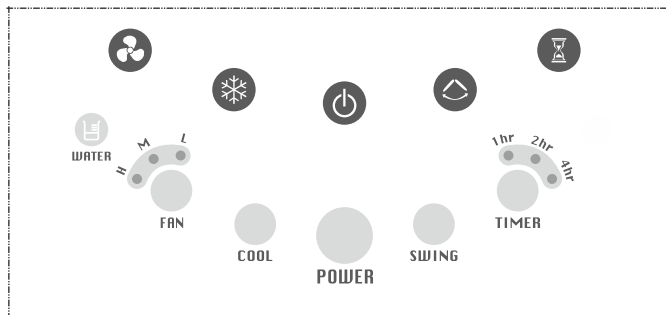

Control Panel*

Remote Control & Control Panel may vary from model to model

1. POWER (ON/OFF) [⏻]: Press the button to switch on/off the cooler. Icon will glow with blue colour at ON position and RED colour at OFF position
2. COOL [❄️]: Press the button to switch ON/OFF the pump. Cool Icon will glow when switched On. The Pump will start only when sufficient water is in the tank, indicated by water icon glowing in WHITE. Low water level will be indicated by a buzzer for 5 seconds and water icon will start blinking in red colour. (Except Diet 12 i, 8 i & Ice Cube i)
3. FAN [🌀]: When started, the fan icon will glow. Press the button for High, Medium and Low speeds. The selected speed will be indicated by glowing LED.
4. SWING [⚡]: Press button to switch on/off the swing function. Swing icon will glow when switched ON
5. TIMER [⌚]: Press the button to set OFF timer from 1 - 7 hours in intervals of 1 hr. Timer icon will glow when timer is switched ON and the glowing LEDs will indicate the total OFF time set.

* Shape and size can vary as per respective models.

Maintenance

1. Disconnect the power cord before servicing or maintenance.
2. Do not make loose wiring or use inferior material in servicing or maintenance to avoid fire hazard.
- 3) Please stop the device and contact the authorized service provider in case of electric shock found on cooler.
- 4) Please disconnect the power supply before opening any cover to avoid injury due to rotating part / electric shock
- 5) To clean the tank remove drain plug from bottom side. Drain out all the residual water. Draining out of stagnant water regularly from tank is necessary to keep your environment hygienic.
- 6)To clean the cooling pad, please unplug the cooler; apply low water pressure with the help of pipe on cooling pad from outside. Depending on the surrounding environment, clean the pad at least once or twice in a year ,
- 7) Under no circumstances, customer should open the cooler.
- 8) In case of any difficulties, please contact symphony customer care help line no. 07930130111
- 9) Always use clean tap water.

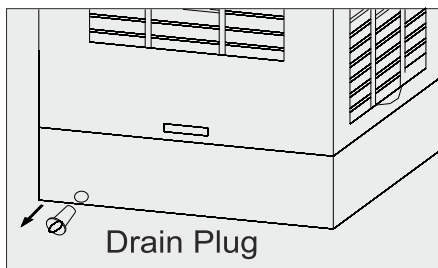

Cleaning of cooler by draining the water

To drain the left over water from the tank pull to remove the drain plug given at the lower back side of the tank. After draining, push to fix the drain plug properly.

It is advisable to drain water on regular basis for better performance & longer life of pads

Trouble Shooting

Trouble	Cause	Remedy
Less Cooling	Pump is switched OFF	Switch ON the pump
	Humidity control OFF (Selected models)	Ensure that the humidity control knob is ON.
	No air circulation	Ensure cross ventilation
Water Leakage	Drain plug is displaced	Ensure that the drain plug is positioned properly
	Grill lock is disengaged	Relock the grill
	Cooling pad is sagged	Change the cooling pads
Fan not Working	Airflow switch is turned OFF	Switch ON the fan by selecting the required speed
	Loose contact at socket	Rectify faulty wiring / Socket in the house
	Switch or Motor Malfunction	Call symphony customer care help line no. 07930130111
Shock on Cooler	Device malfunction	Call symphony customer care help line no. 07930130111

Note : The blower/fan motor comes equipped with thermal overload protection.

Electrical Specifications

Rated Voltage / Frequency -220V/60Hz, 110V/60Hz, 230/50Hz single Phase														
Tech Specs	Model	Winter	Sivara 45	Sivara 70	Sumo	Sumo jr	Jumbo	Jumbo jr	Kazari jr	Ninja	Ice Cube XL	DiET 8T 230V/50T	DiET 50T	
	Rated Power (watts)	220 V/60Hz	200	180	180	180	185	155	110	100	110	110	95	185
110 V/60Hz		190	195	195	195	175	210	120	100	105	105	105	185	175
230-240V/50Hz		185	160	160	160	150	185	110	95	105	105	95	170	170
Rated Current (A)	220 V/60Hz	1.0	0.9	0.9	0.9	0.85	0.73	0.5	0.5	0.5	0.55	0.48	0.85	0.9
	110 V/60Hz	1.9	1.6	1.6	1.6	1.6	1.8	1.0	1.0	1.1	1.1	1.1	1.9	1.8
Insulation Class		□	□	□	□		□	□		□	□	□	□	□

Symphony Limited
Symphony House, FP12-TP50 Bodakdev, Off SG Highway,
Ahmedabad 380054, India. www.symphonylimited.com **MADE IN INDIA**

Non Remote Models

Rated Voltage / Frequency -220V/60Hz, 110V/60Hz, 230/50Hz single Phase												
Tech Specs	Model	Sum 100	Sum 70i	Winter i	Hi cool i	DiET 50i	DiET 35i	DiET 22i	DiET 12i	DiET 8T/CR	Ninja i	Ice Cube i
	Rated Power (watts)	220 V/60Hz	250	350	205	195	175	185	185	95	95	110
110 V/60Hz		280	365	195	210	175	185	185	105	105	105	105
230-240V/50Hz		270	365	190	185	170	170	170	95	95	105	105
Rated Current (A)	220 V/60Hz	1.2	1.6	1.0	1.0	0.9	0.85	0.85	0.48	0.48	0.5	0.55
	110 V/60Hz	2.6	3.1	1.9	2.1	1.8	1.9	1.9	1.1	1.1	1.1	1.1
Insulation Class		□	□	□	□	□	□	□	□	□	□	□

Symphony Limited
Symphony House, FP12-TP50 Bodakdev, Off SG Highway,
Ahmedabad 380054, India. www.symphonylimited.com **MADE IN INDIA**

Remote Models

Note : DiET can come with variant T/CR/E/i,

WIRING DIAGRAMS

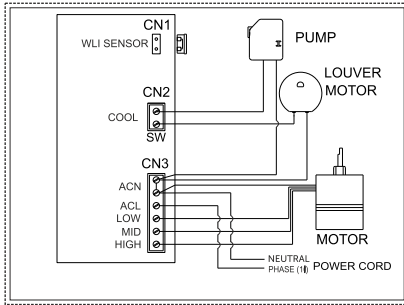

CLASS II MODELS : Diet 8i, 12i & Ice Cube i™ MODELS.

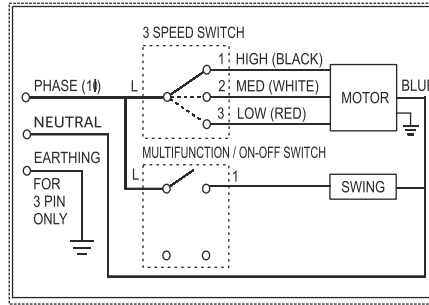

CLASS I MODELS : KAIZEN JR. & SUMO JR.

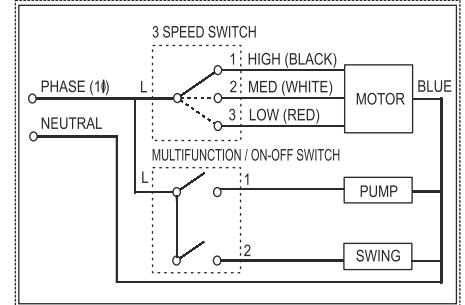

CLASS II MODELS : JUMBO, JUMBO JR., WINTER, SIESTA 45 & 70, SUMO, ICE CUBE XL, NINJA, DIET 8T, 12T, 22T & 50T.

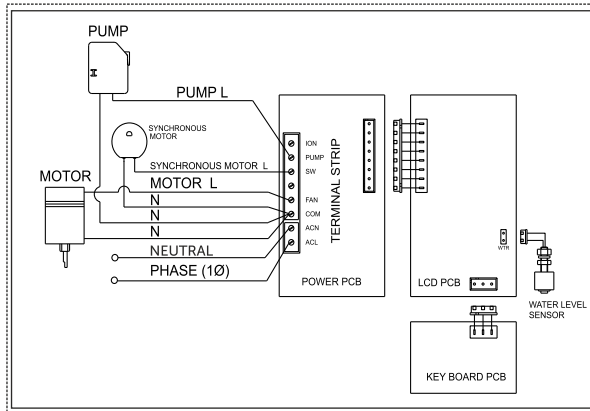

CLASS II MODELS : STORM 100 i & STORM 70 i.

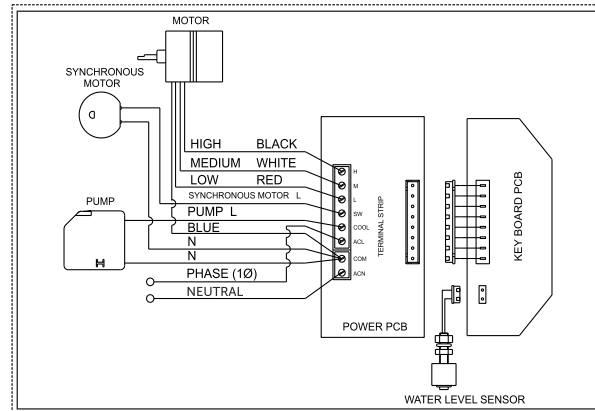

CLASS II MODELS : DIET 22i, DIET 35i, DIET 50i, HI COOL i, NINJA i & WINTER i.

Warnings

1. Unplug and disconnect the cooler from power source before attempting any maintenance, service or cleaning and filling water.
2. If the supply cord is damaged, it must be replaced by the manufacturer, its service provider in order to avoid hazard. Do not operate the product with a damaged power cord or plug.
3. To avoid electric shock, connect only to an outlet provided with a ground fault circuit interrupting device. (ELCB = Earth leakage current breaker)
4. This appliance is not intended for use by persons (including children) with reduced physical, sensory or mental capabilities, or lack of experience and knowledge, unless they have been given supervision or instruction concerning use of the appliance by a person responsible for their safety.
5. Children of less than 3 years should be kept away unless continuously supervised.
6. Children aged from 3 years and less than 8 years shall only switch on/off the appliance provided that it has been placed or installed in its intended normal operating position and they have been given supervision or instruction concerning use of the appliance in a safe way and understand the hazards involved. children aged from 3 years and less than 8 years shall not plug in, regulate and clean the appliance or perform user maintenance
7. Children must not be allowed to play with cooler.
8. This appliance is not intended to be used in locations where special conditions prevail, such as the presence of a corrosive or explosive atmosphere (vapour or gas).
9. This appliance can be used by children aged from 8 years and above and persons with reduced physical, sensory or mental capabilities or lack of experience and knowledge if they have been given supervision or instruction concerning use of the appliance in a safe way and understand the hazards involved. Children shall not play with the appliance. Cleaning and user maintenance shall not be made by children without supervision.

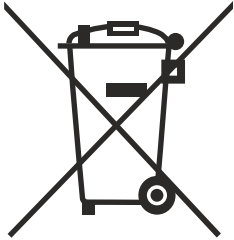

This marking indicates that this product should not be disposed off with other household wastes throughout the EU and other applicable countries. To prevent possible harm to the environment or human health from uncontrolled waste disposal, recycle it responsibly. If you wish to discard this product please contact your local authorities or dealer from where it was purchased and ask for correct method of disposal.

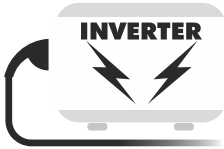

Symphony cooler works on inverter. The inverter should be of sine-wave type of appropriate rating.



Cooling performance depends on temperature of water used, relative humidity, and ambient temperature.

WARRANTY REGISTRATION CARD

Date of Purchase ___/___/_____

Model : _____

Name : _____

Address : _____

E-mail : _____

Mobile : _____ Phone : _____

Product Sr. No.

Condition of warranty

We extend this limited warranty to the original buyer (first retail purchaser) and warranty that the product shall be free from manufacturer defects in workmanship and materials for 12 months from the date of purchase. a. Warranty will come in with effect when the following conditions are met with: a) Warranty registration card duly filled and received by the company within 10 days from the date of purchase. b) Product is operated following the recommendations explained inside the user manual. b. The company's liability under the warranty will be limited only to motor, pump, louver motor, remote, PCB and also restricted to any such defect which occurs under conditions of normal operations and under proper use. Any part/s replaced by the company at its discretion shall be a functionally operative unit. c.This warranty shall not apply to product: 1) Which have not been purchased from authorized distributor through their network or company's authorized retail stores, 2) Which have been altered/opened by any other personnel not authorized by the company, 3) Incorrectly used in combination with any other substance or products, 4) Which are used for commercial rental purpose and / or which develops problems due to faulty care or maintenance and alterations to product or its parts. 5) Which is subjected to electrical supply for which the product is not designed, 6) Warranty will void if the product is operated with a sub-standard inverter or non-sine wave inverter. 7) If documentation of buying is not available to validate an original purchase. d. While the company will make every effort to carry out the repairs at the earliest, it however is made expressly clear that the company is under no obligation to do so in a specified period of time. e. This warranty shall automatically terminated on expiry of the warranty period of 12 months from the date of purchase even if the product may not be used for any time during the warranty period for any reason whatsoever. f. Cooling pads and outer plastic parts are not covered under warranty. g. The company shall not be liable in any case for any loss or damage caused to any property, death or disability caused to any human life arising out of fire, electrical fault, short circuit, accidental handling or any kind of natural calamity. As, such the company's liability is limited to the cost of the spare parts of the said products only. h. Change of address of the customers must be intimated to the company without which the warranty shall not be operational. i. Due to ongoing research and development, the company holds the rights to modify the product without any prior notice or obligation to buyers. j. Purchaser should retain the purchase bill as evidence of the date of purchase. Copy of the purchase invoice should be given to the visiting service technician while attending the complaint. In case of any alteration in the date of purchase invoice is found without sign and seal of the dealer, the warranty shall be void. k. During the warranty, customer is not entitled for exchange of product or refund money. l. The company does not have any Annual Maintenance Contract (AMC) policy. m. The court/Consumer forums only at Ahmedabad, Gujarat, India shall have exclusive jurisdiction for any disputes arising out of this sale/transaction. n. Service for this product shall be provided by Authorized Service Provider. You may register warranty by log on to www.symphonylimited.com/warranty or you may send SMS <sym, name, city, pin code, serial number> to 951080111. Warranty will be applicable if registered within 15 days of purchase. O The above warranty conditions shall be applicable for domestic service only to the sales in the domestic markets of India only, excluding Northern Eastern states, Andaman and Lakshadweep. For overseas market the warranty will be given by the local distributor of the respective country. P. To register service request Please use either of the following ways to register your request.

- You may call on our all India help line No. 07930130111.
- You may send SMS to 09510070111 giving details as <name city pin code serial no.>
- You may log in through our website "symphonylimited.com/service".

Symphony Limited

Symphony House, FP12-TP50 Bodakdev,
Off SG Highway, Ahmedabad 380054, India.

E-mail : services@symphonylimited.com

Dealer's name
& signature

Symphony Limited

Symphony House, FP12-TP50 Bodakdev, Off SG Highway, Ahmedabad 380054, India.
E-mail : services@symphonylimited.com

Revision 07 - Date 02-09-2015

natural cooling

Symphony[®]

www.symphonylimited.com