

Operating and Installation Instructions Built-in Coffee Machine



Always read the operating instructions before setting up, installing, and commissioning the appliance.
This prevents both personal injury and damage to the appliance.

Contents

Warnings and safety instructions	5
Preparing your appliance for an extended vacation.....	13
Guide to the appliance	16
Controls and indicators	18
Using the appliance	20
Symbols in the display	22
Initial commissioning	23
Miele@home	23
Before using for the first time	24
Switching on for the first time	24
Filling the bean containers	26
Filling the water container	27
Switching on and off	28
Spout adjustment	29
Preparing drinks	30
Making coffee with and without milk.....	30
Milk preparation.....	31
Making a coffee drink.....	32
Cancelling a drink.....	32
DoubleShot.....	32
Making 2 portions (☐ sensor button)	33
Coffee jug	33
Tea.....	34
TeaTimer.....	35
Making tea.....	35
Tea pot.....	36
Dispensing warm or hot water	36
.....	37
Grinder setting	38
Parameters	39
Displaying and changing parameters.....	39
Portion size.....	39
Quantity of coffee.....	40
Brewing temperature	40

Pre-brewing the ground coffee.....	40
Profiles	41
Creating a profile	41
Changing drinks within a profile	41
Making drinks stored in a profile	41
Editing profiles.....	41
Setting when the profile should change	41
Changing the name	42
Deleting a profile	42
MobileStart	43
Settings	44
Displaying and changing Settings	44
Language.....	44
Time of day.....	44
Date	44
Timer	44
On at.....	44
Off at.....	45
Off after	45
TeaTimer.....	45
Volume.....	45
Display brightness.....	45
Lighting.....	45
Info (display information)	45
Altitude	45
Performance Mode.....	45
Eco Mode	46
Barista Mode	46
Latte Mode	46
Party Mode	46
Water hardness	46
System lock 	47
Miele@home	48
Remote control.....	48
RemoteUpdate	48
Software version.....	49
Showroom program (demo mode)	49
Factory default settings.....	49
Cleaning and care	50
Overview of cleaning intervals.....	50

Contents

Cleaning by hand or in the dishwasher	51
Unsuitable cleaning agents	52
Cleaning the drip tray and grounds container	53
Cleaning the drip tray cover	55
Cleaning the water container	55
Cleaning the central spout	55
Cleaning the cup rim sensor	57
Cleaning the milk container with lid	58
Cleaning the milk valve (daily)	58
Removing and cleaning the milk valve (once a month)	59
Cleaning the bean containers	62
Cleaning the interior, inside of the appliance door, and drip tray	63
Cleaning the appliance front	63
Maintenance programs	64
Rinse appliance	64
Rinse milk pipework	64
Degreasing the brew unit and cleaning the interior	65
Descaling the appliance	68
Frequently Asked Questions	70
Messages in the display	70
Unusual performance of the coffee machine	73
Unsatisfactory results	76
Service and warranty	78
Contact in the event of a fault	78
Warranty	78
Accessories	79
Caring for the environment	80
Installation	81
Electrical connection	81
Installation dimensions	82
Building in the coffee machine	84
Door opening limiters	85

Warnings and safety instructions

This coffee machine complies with all current local and national safety requirements. Inappropriate use can, however, lead to personal injury and material damage.

Read the operating instructions carefully before using the coffee machine. They contain important notes on installation, safety, operation, and maintenance. This prevents both personal injury and damage to the coffee machine.

In accordance with standard IEC 60335-1, Miele expressly and strongly advises you to read and follow the instructions in the chapter on installing the coffee machine as well as the safety notes and warnings.

Miele cannot be held liable for injury or damage caused by non-compliance with these instructions.

Keep these operating instructions in a safe place and pass them on to any future owner.

Warnings and safety instructions

Appropriate use

- ▶ This coffee machine is intended for home use.
- ▶ The coffee machine is not suitable for outdoor use.
- ▶ This coffee machine must not be used at altitudes above 2,000 m.
- ▶ The machine is intended only for domestic use and for the preparation of drinks such as espresso, cappuccino, latte macchiato, tea, etc. All other types of use are not permitted.
- ▶ This coffee machine can only be used by people with reduced physical, sensory, or mental capabilities or lack of experience and knowledge if they are supervised whilst using it.
They may only use the coffee machine without supervision if they have been shown how to use it in a safe manner. They must be able to recognize and understand the possible consequences of incorrect operation.

Safety with children

 Danger of burning and scalding on the dispensing spouts.

Children's skin is far more sensitive to high temperatures than that of adults.

Ensure children do not touch hot surfaces of the coffee machine or place parts of their body under the dispensing spouts.

- ▶ Install the coffee machine where it is out of the reach of children.
- ▶ Children under 8 years of age must be kept away from the coffee machine unless they are constantly supervised.
- ▶ Children aged 8 and older may only use the coffee machine without supervision if they have been shown how to use it in a safe manner.
Children aged 8 and older must be aware of the potential dangers caused by incorrect operation.
- ▶ Children should be supervised in the vicinity of the coffee machine. Never allow children to play with the appliance.
- ▶ Young children must not be allowed to clean the coffee machine at all. Cleaning may only be carried out by children 8 years of age or older under the supervision of an adult.
- ▶ Keep in mind that espresso and coffee are not suitable drinks for children.
- ▶ Danger of suffocation. While playing, children may become entangled in packaging material (such as plastic wrapping) or pull the packaging material over their head, presenting the risk of suffocation. Keep packaging material away from children.

Warnings and safety instructions

Technical safety

- ▶ Installation work or repairs should only be carried out by a Miele authorized technician. Unauthorized or incorrect installation work or repairs can pose considerable danger to users.
- ▶ Damage to the coffee machine can compromise your safety. Before installing the appliance, check it for visible signs of damage. Do not use the appliance if it is damaged.
- ▶ Before connecting the coffee machine, make sure that the connection data on the data plate (voltage and frequency) matches that of the domestic electrical supply. This data must match to prevent the coffee machine from being damaged. Consult a qualified electrician if in any doubt.
- ▶ The electrical safety of this coffee machine can only be guaranteed when correctly grounded. It is essential that this basic safety requirement is fulfilled. If in doubt, the electrical installation should be checked by a qualified electrician.
- ▶ Reliable and safe operation of the coffee machine can only be guaranteed if it is connected to the domestic electrical supply.
- ▶ Do not connect the coffee machine to the domestic electrical supply using a multi-socket adapter or an extension cord. These do not guarantee the required safety of the appliance (risk of fire).
- ▶ The coffee machine may not be used in mobile installations such as ships.
- ▶ For safety reasons, this machine may only be used when it has been built in.
- ▶ Do not place on or near a hot gas or electric burner, or in a heated oven.
- ▶ Unplug the coffee machine from the domestic electrical supply immediately if you notice any damage or smell scorching, for example.

Warnings and safety instructions

- ▶ Ensure that the power supply cable will not be pinched or damaged by any sharp edges.
- ▶ To reduce the risk of injury, do not drape cord over the counter top or table top where it can be pulled on by children or tripped over unintentionally.
- ▶ Do not operate any appliance with a damaged cord or plug or after the appliance malfunctions, or has been damaged in any manner. Return appliance to the nearest authorized service facility for examination, repair or adjustment.
- ▶ To protect against fire, electric shock and injury to persons do not immerse cord or plugs in water or other liquid.
- ▶ To reduce the risk of fire:
 - Do not place any heating or cooking appliance beneath the appliance without a shelf in between.
 - Do not mount unit over or near any portion of a heating or cooking appliance without a shelf in between.
 - Do not mount over a sink.
 - Do not store anything directly on top of the appliance surface when the appliance is in operation.
- ▶ If the coffee machine is to be built in above another appliance, there must be a full-width, closed shelf between them (except when it is combined with a suitable built-in dishware / food warming drawer).
- ▶ Only use the coffee machine in rooms where the ambient temperature is between +60°F (16°C) and +100°F (38°C).
- ▶ A minimum installation height of 850 mm must be observed.
- ▶ This coffee machine must not be installed behind a closed cabinet door front. Heat and moisture can build up behind the cabinet door front when closed. This can result in damage to the machine and / or cabinetry.

Warnings and safety instructions

► For repairs, the coffee machine must be disconnected from the domestic electrical supply.

The coffee machine is only disconnected from the domestic electrical supply if

- the circuit breaker has been tripped.
- the fuse is removed.
- the power supply cable has been unplugged.

To do this, pull only the plug, not the power supply cable.

► While the coffee machine is under warranty, repairs should only be undertaken by a service technician authorized by Miele Service. Otherwise the warranty will be invalidated.

► Do not open the coffee machine housing under any circumstances. Any contact with live connections or tampering with the electrical or mechanical components of the coffee machine will endanger your safety and may lead to appliance malfunctions.

Correct use

 Danger of burning and scalding on the dispensing spouts. The liquids and steam dispensed are very hot.

Keep away from the area underneath the spouts when hot liquids and steam are being dispensed.

Do not touch hot components.

Hot liquid or steam could spatter from the nozzles. Ensure that the central spout is clean and installed correctly.

Before opening the door, remove any containers from the drip tray in the door.

Water in the drip tray can also be very hot. Take care when emptying it.

Warnings and safety instructions

 Risk of injury to the eyes!

Never look directly at the lighting or use optical instruments (e.g., magnifying glass) to look at it.

- ▶ Please note the following regarding water:
 - The water quality must conform to the requirements for drinking water in the country in which the coffee machine is being used.
 - Only use cold, fresh tap water to fill the water container. Hot or warm water or other liquids can damage the coffee machine.
 - Change the water every day to prevent a build-up of bacteria.
 - Do not use sparkling water.
- ▶ Only put roasted coffee beans in the bean containers. Do not place coffee beans which have been treated with additives or ground coffee inside the bean containers.
- ▶ Do not fill the bean containers with any type of liquid.
- ▶ Do not use green (unroasted) coffee beans or mixtures of coffee beans which contain green coffee beans. Green coffee beans are very hard and still contain residual moisture. These can damage the coffee machine grinder as soon as grinding begins.
- ▶ Do not use coffee beans that have been treated with sugar, caramel, or other substances and do not put liquids containing sugar in the coffee machine. Sugar will damage the appliance.
- ▶ The milk used must not contain any additives. Most additives contain sugar which would stick to the milk pipework.
- ▶ If using dairy milk make sure that it has been pasteurized.
- ▶ When making tea, please follow the instructions on the tea packaging.
- ▶ Do not place flaming alcohol mixtures underneath the central spout. The flames could ignite plastic components and cause them to melt.

Warnings and safety instructions

- ▶ Do not hang on to the open appliance door or place any objects on it as this will damage the hinges of the coffee machine.
- ▶ Do not use the coffee machine to clean any other objects.

Warnings and safety instructions

Preparing your appliance for an extended vacation

▶ If you elect to turn off the water to your home for an extended period of time, please note that this may not be enough to reduce the risk of a leak. To be completely safe, you must turn off the water supply to each individual appliance. This means under the sink for a dishwasher, at the laundry bib for your washer, etc.

Accessories and spare parts

▶ Miele can only guarantee the safety of the appliance when original Miele parts are used. Faulty components must only be replaced with genuine Miele replacement parts.

▶ The use of accessory attachments not recommended by the appliance manufacturer may result in fire, electric shock or injury to persons.

▶ Only use original Miele accessories. If other parts are used, warranty, performance, and / or product liability claims will be invalidated.

▶ Miele will guarantee to supply functional spare parts for a minimum of 10 years and up to 15 years following the discontinuation of your coffee machine.

Cleaning and care

▶ Unplug from outlet when not in use and before cleaning. Allow to cool before putting on or taking off parts, and before cleaning the appliance.

▶ Clean the coffee machine and the milk container daily, particularly before using for the first time.

▶ Ensure that all components in which milk is transported are cleaned carefully on a regular basis. Milk naturally contains bacteria that rapidly multiply if the milk pipework is not cleaned properly.

Warnings and safety instructions

- ▶ Descale the coffee machine regularly depending on the water hardness. Descale the appliance more frequently if you use hard water. Miele cannot be held liable for damage resulting from not descaling the machine, using the wrong descaling agent, or an unsuitable descaling solution concentration.
- ▶ Degrease the brew unit regularly with the cleaning tablets. Depending on the natural oil content of the coffee used, the brew unit can become blocked quite quickly.
- ▶ Do not use a steam cleaner to clean the appliance. The steam could reach live electrical components and cause a short circuit.
- ▶ The espresso / coffee grounds must be disposed of in the organic waste or compost, not in the sink. The drain can clog up as a result.

Warnings and safety instructions

For coffee machines with stainless steel surfaces:

- ▶ Do not use sticky notes, adhesive tape, or other types of adhesive on the stainless steel surfaces. These will damage the stainless steel surfaces, causing them to lose their dirt-repellent protective coating.
- ▶ The finish on stainless steel surfaces is susceptible to scratching. Even magnets can cause scratches.

SAVE THESE INSTRUCTIONS

Guide to the appliance

Exterior view

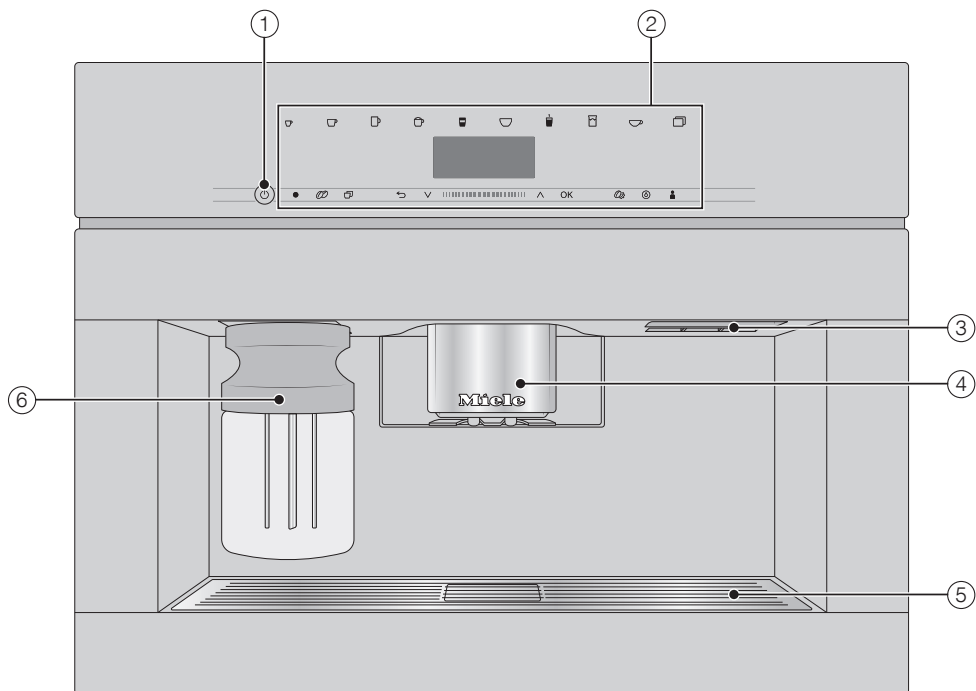

- ① On / Off button ①
- ② Control panel
- ③ Door handle
- ④ Height-adjustable central spout with lighting
- ⑤ Drip tray cover
- ⑥ Milk container

Interior view

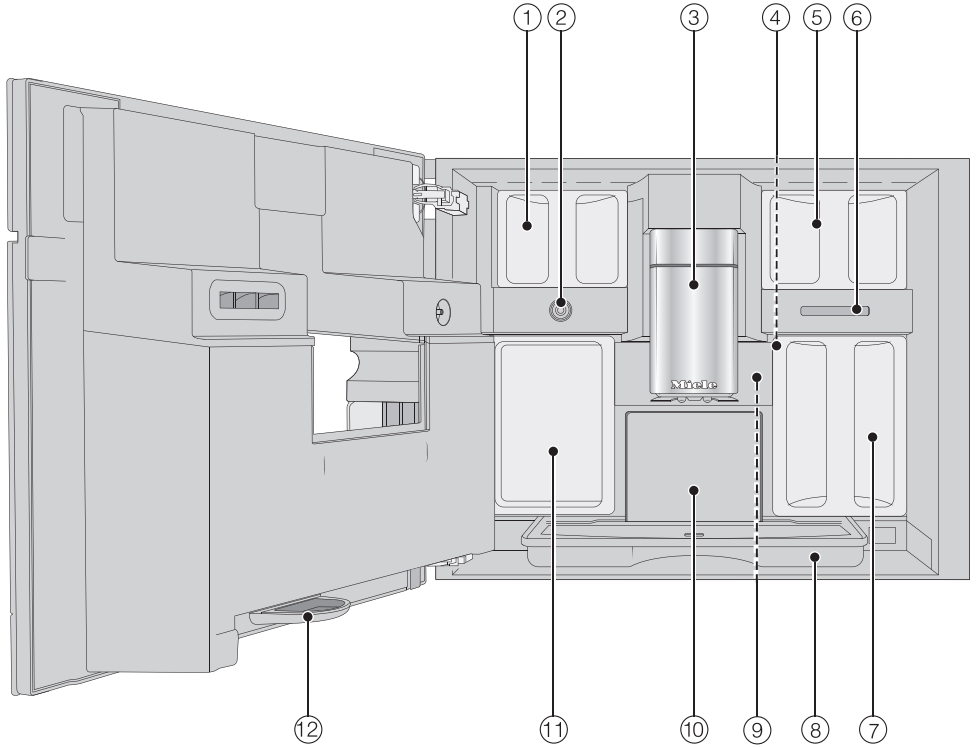

- ① Bean container
- ② Milk valve
- ③ Height-adjustable central spout with lighting
- ④ Grinder setting
- ⑤ Bean container
- ⑥ Fan outlet
- ⑦ Water container
- ⑧ Drip tray with lid
- ⑨ Brew unit
- ⑩ Grounds container
- ⑪ Maintenance container
- ⑫ Drip tray

Controls and indicators

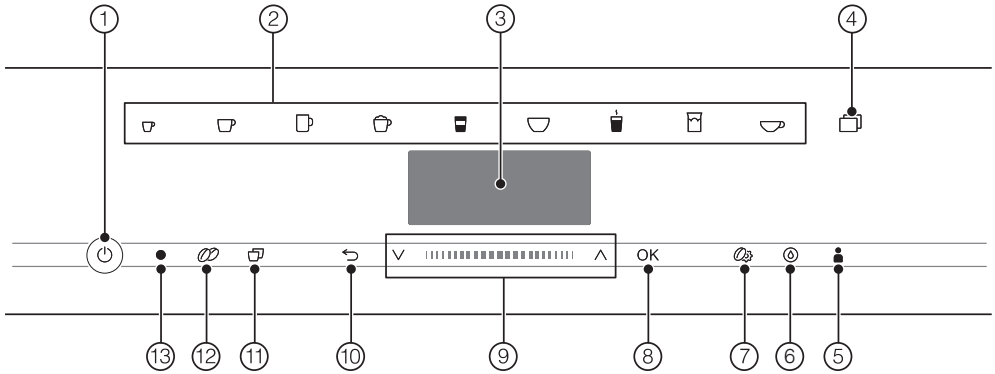

- ① **On / Off button**

For switching coffee machine on and off
- ② **Drink buttons**

For making drinks
- ③ **Display**

For showing information about the current action or status
- ④ **sensor button**
 - For making other drinks, e.g., ristretto, cappuccino italiano
 - For making a pot of tea or coffee
 - Settings menu
- ⑤ Profiles **sensor button**

For creating and managing profiles
- ⑥ Maintenance **sensor button**

Maintenance programs, e.g., Descale
- ⑦ Parameters **sensor button**

For displaying or changing drink settings
- ⑧ **OK sensor button**

For confirming display messages and saving settings
- ⑨ **Navigation area with arrow buttons**

For scrolling through lists, selecting entries, or changing values
- ⑩ **“Back”** **sensor button**









For returning to the previous menu and cancelling unwanted actions
- ⑪ **“2 portions”** **sensor button**

For dispensing 2 portions of a drink at once
- ⑫ **“DoubleShot”** **sensor button**

For making a particularly strong and aromatic coffee by using twice as much ground coffee but the same amount of water
- ⑬ **Optical interface**

(for Miele Service only)

Drink button symbols

-  Espresso
-  Coffee
-  Long coffee
-  Cappuccino
-  Latte macchiato
-  Caffè latte
-  Hot milk
-  Milk froth
-  Tea water

Using the appliance

Sensor buttons

To operate the coffee machine, tap the sensor buttons with your finger.

An audible signal is generated each time a button is tapped. You can adjust the volume of the signal tones or switch the tones off (see “Settings – Volume”).

Drinks menu

When the following appears in the display, you are in the drinks menu: Select drink.

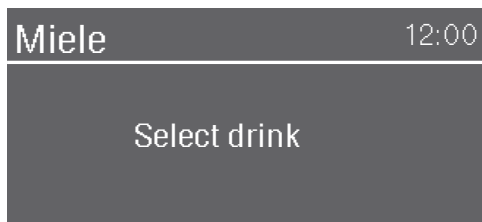

You can find more drinks in the Additional menu (☐ sensor button).

Navigation area

To select a menu option, keep pressing the arrow buttons ^ and v until the option you want is highlighted.

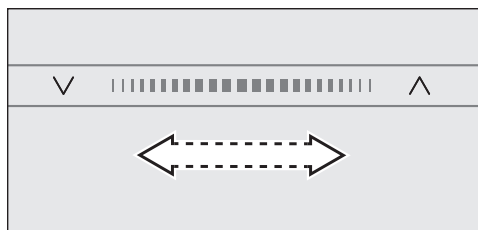

To scroll more quickly through the options, swipe your finger right or left in the area between the arrows.

As soon as you reach a confirmable value, message, or setting, the OK sensor button will light up orange.

Touch the OK sensor button to confirm your selection.

Selecting a menu and navigating within a menu

To select a menu, tap the relevant sensor button, e.g., the ☐ sensor button.



You will then be able to start an action or change settings in the menu. A scroll bar at the right of the display shows that additional options or text are available.

The setting which is currently selected in a list will have a check ✓ beside it.

Exiting a menu or cancelling an action

To exit the current menu, touch the ↵ sensor button.



Alternatively, tap the lit orange sensor button again to return to the drinks menu.

Entering a name

Letters and numbers are entered via the navigation area. You can choose between upper and lower case letters.

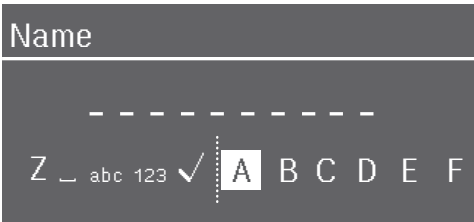
Useful tip: It is best to select short, memorable names.











- To enter a character, highlight the one you want and confirm your choice with *OK*.
- To delete a character, touch the  sensor button.
- To save the name, select the check  and confirm with *OK*.

Using the appliance

Symbols in the display

The following symbols may also appear in the display in addition to the text:

Symbol	Explanation
	This symbol indicates the “Settings” menu and the “Language” menu option.
	This symbol indicates that there is additional information and advice about using the coffee machine. Select OK to confirm the information.
	This symbol appears if the system lock is activated. The controls are locked.
	The symbol and the desired switching-on time appear in the display 23:59 hours before the coffee machine is due to switch on if the Turn on at timer and setting for displaying the time are activated (see “Settings – Timer”).
	The TeaTimer minute minder has been started (see “Tea – TeaTimer”). The remaining brewing time is shown next to the symbol.
	This symbol appears while the appliance is being descaled. (This symbol can also be found on the water container: fill up to this mark).
	This symbol appears during the Clean milk pipework maintenance program. (This symbol is also found on the water container: fill up to this mark with water.)
	If Miele@home has been activated for the coffee machine, these symbols represent the quality of the Wi-Fi connection. They indicate the strength of the Wi-Fi connection in increments from strong to not connected.

Miele@home

Your coffee machine is equipped with an integrated Wi-Fi module.

To use this feature, you will need:

- a Wi-Fi network
- the Miele app
- a Miele user account You can create a user account via the Miele app.

The Miele app will guide you through the process of connecting your coffee machine to your home Wi-Fi network.

Once your coffee machine is connected to your Wi-Fi network, you can use the app to carry out activities such as the following:

- calling up information on the operating status of your coffee machine
- changing settings on your coffee machine
- controlling your coffee machine remotely

Connecting your coffee machine to your Wi-Fi network will increase energy consumption, even when the machine is switched off.

Before installing the coffee machine in its final location, ensure that the signal from your Wi-Fi network is strong enough.

Availability of the WiFi connection

The WiFi connection shares a frequency range with other appliances (including microwave ovens and remote control toys). This may result in sporadic or even complete connection failures. Therefore, the availability of featured functions cannot always be guaranteed.

Miele@home availability

The ability to use the Miele app depends on the availability of the Miele@home service in your country.

The Miele@home service is not available in every country.

For information about availability, please visit www.miele.com.

Miele app

The Miele App is available to download free of charge from the Apple App Store[®] or from the Google Play[™] store.



Initial commissioning

Before using for the first time

- Connect the coffee machine to the electricity supply.
- Install the coffee machine.
- Remove any notices from the machine.
- Remove the protective foil from the drip tray cover.
- Clean the water container, the bean containers, and the central spout.
- Remove the water container and fill it with fresh, cold tap water. Only fill the water container up to the “max.” mark and then reinsert it in the machine (see “Filling the water container”).
- Remove the bean containers and fill them with roasted coffee beans.

Switching on for the first time

- Touch the On / Off button .

Selecting the display language

- Select the desired display language.

You might also be asked for your location.

The choice of location determines how the time of day is displayed, e.g., in the 12 or 24-hour format, as well as how units are displayed and so on.

Setting up the network (Miele@home)

You can connect your coffee machine to your Wi-Fi network.

The following appears in the display during set-up: Set up “Miele@home”

Useful tip: You can also choose to set up Miele@home for your coffee machine at a later point. In this case, select *Skip*.

- Make sure that your Wi-Fi network signal is sufficiently strong in the place where you want to set up your coffee machine.
- Tap *Continue*.
- Select the connection method you wish to use.
- Follow the instructions provided in the coffee machine display and in the Miele app.

Connection successfully established will appear on the display.

- Tap *Continue* to proceed with the set-up.

Setting the date

- Set the current date and tap *OK*.

Setting the time

- Set the current time of day and tap *OK*.

If the coffee machine has been connected to a Wi-Fi network and signed into the Miele app, the time will be synchronized based on the location setting in the Miele app.

Setting the water hardness

Your local water authority will be able to tell you the hardness of the water in your area.

More information can be found under in “Water hardness” under “Settings”.

- Enter your local water hardness (in °dH) and confirm with *OK*.

Selecting the Performance Mode

You can select the appropriate mode to suit your personal preferences (see “Settings – Performance Mode”).

- **Eco Mode:** This is an energy-saving mode.
 - **Barista Mode:** This mode has been optimized for unadulterated coffee enjoyment.
 - **Latte Mode:** In this mode, milk-based drinks can be prepared within a much shorter space of time.
- Select the desired mode and confirm with *OK*.

Your machine has been successfully set up and is ready for use.

To ensure that any coffee residues from the factory testing process are removed from the brewing system, please throw away the first 2 cups of coffee when using the coffee machine for the first time.

Filling the bean containers

Coffee or espresso can be made from whole roasted coffee beans which are freshly ground for each cup. This requires the bean containers to be filled with coffee beans.

 Risk of damage to the grinder due to incorrect operation.

The coffee machine will be damaged if the bean container is filled with unsuitable substances such as liquids, ground coffee, or coffee beans treated with sugar, caramel, or similar.

In addition, green (unroasted) coffee beans or mixtures of coffee beans which contain green coffee beans can damage the grinder. Green coffee beans are very hard and still contain residual moisture. These can damage the coffee machine grinder as soon as grinding begins.

Only put roasted coffee beans in the bean containers.

The coffee machine has 2 bean container drawers on the top left and right. Coffee beans from all 3 bean containers are mixed together during grinding.



- Open the appliance door.

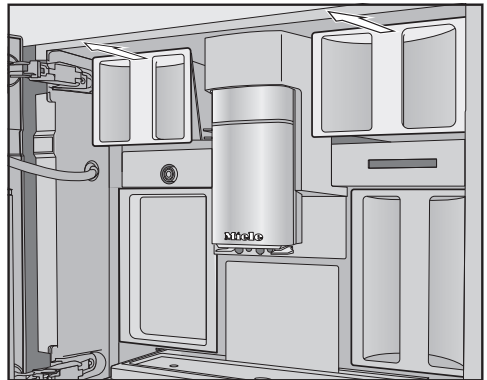

- Pull out the bean containers.
- Take the lids off the bean containers and fill them with coffee beans.
- Put the lids back on the bean containers to seal them.
- Slide the bean container drawers all the way into the coffee machine. Close the appliance door.

Filling the water container

⚠ Risk to health due to contaminated water.

Bacteria can develop in water which has been sitting in the water container for too long and is a risk to your health.

Change the water in the water container **every day**.

⚠ Risk of damage due to incorrect operation.

Unsuitable liquids such as hot or warm water or other liquids can damage the coffee machine.

Carbonated water leaves too much limescale in the coffee machine.

Only use cold, fresh tap water to fill the water container.

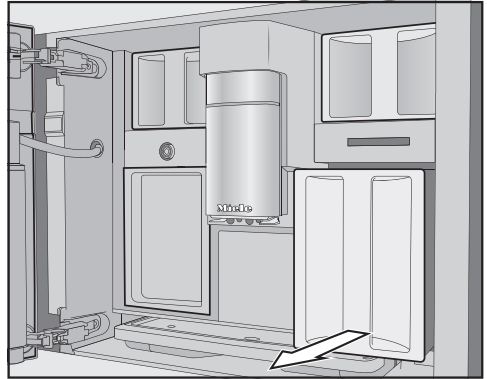

- Pull the water container forwards to remove it.
- Fill the water container with fresh, cold drinking water up to the *max.* mark.
- Push the water container into the machine and close the door.

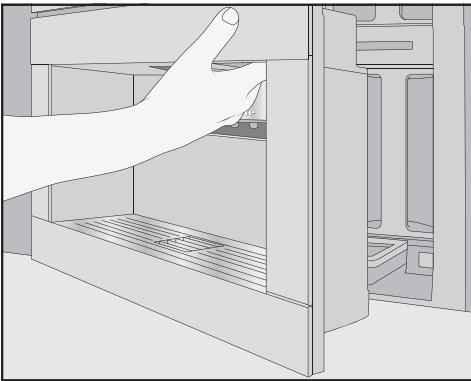

- Open the appliance door.

Switching on and off

Switching the coffee machine on

- Touch the On / Off button ①.

The coffee machine heats up and rinses the pipework. Hot water will run out of the central spout.

You can now make drinks.

If the coffee machine is already at operating temperature, rinsing will not take place when the appliance is switched on.

While dispensing a drink or during maintenance processes, moisture builds up in the coffee machine. Once a drink has been dispensed or the appliance has been switched off, the internal fan will continue to run until the interior is sufficiently dehumidified. You will hear an accompanying noise.

Switching the coffee machine off

- Touch the On / Off button ①.

If coffee has been dispensed, the coffee machine will rinse the pipework automatically before switching off.

Switching off for longer periods of time

If the coffee machine is not going to be used for a while, e.g., if you are going on vacation, remember to do the following:

- Empty the drip tray, the grounds container, and the water container.

- Clean all parts thoroughly, including the brew unit and interior of the machine.
- Switch the coffee machine off.

The central spout **cannot** be manually adjusted.

Before making the drink, the central spout moves down and the cup rim sensor stops it at the optimum height for the cups or glasses being used.

When the coffee machine is switched off, the central spout will be in the middle position.

When a maintenance program is being carried out, the central spout will move to the height of the maintenance container or into a low maintenance position.

Make sure that the central spout is in the top or middle position before you open the door.

Preparing drinks



Danger of burning and scalding on the dispensing spouts.

The liquids and steam dispensed are very hot and can cause scalding.

Keep away from the area underneath the spouts when hot liquids and steam are being dispensed.

Do not touch hot components.

Making coffee with and without milk

The following drinks can be made:

- **Ristretto** is a strong, concentrated espresso. It is prepared with the same amount of coffee as for an espresso but with a lot less water.
- **Espresso** is a strong aromatic coffee with a thick hazelnut-brown coloured froth – known as the crema – on top. We recommend using espresso-roasted coffee beans to make an espresso.
- **Coffee** differs from espresso by the increased amount of water and the roast of the beans. We recommend using coffee beans of the correct roast to make the coffee.
- **Long coffee** is a coffee with considerably more water.
- **Long black** is made with hot water and two shots of espresso.
- **Caffè Americano** consists of espresso and hot water. The espresso is made first, then the hot water is dispensed.

- **Cappuccino** consists of approx. 2 thirds milk froth and 1 third espresso.
- **Latte macchiato** consists of 1 third each of hot milk, milk froth, and espresso.
- **Caffè latte** consists of espresso and hot milk.
- **Cappuccino italiano** has the same proportions of milk froth and espresso as a cappuccino. The difference is that the espresso is added first and then the milk froth.
- **Espresso macchiato** is an espresso with a small amount of milk froth on top.
- **Flat white** is a special variety of cappuccino that contains significantly more espresso than milk froth for an intensive coffee aroma.
- **Café au lait** is a French style of coffee consisting of coffee and milk froth. Café au lait is usually served in a bowl.

Hot milk and **milk froth** can also be made.

Milk preparation

Milk or milk alternatives (e.g., soy milk) containing added sugar can clog up the milk pipe and the rest of the milk pipework. Residues from unsuitable liquids can interfere with milk preparation.

The milk used must not contain any additives.

Only use pasteurized cow's milk.

Useful tip: Using cold cow's milk (< +50°F /+10°C) with a protein content of at least 3% will produce the perfect milk froth.

You can select milk with a fat content according to your personal preference. With whole milk (at least 3.5% fat), the milk froth will be slightly creamier than with low-fat milk.

The milk container

Milk is **not** cooled in the milk container. For high-quality milk froth, always use cold milk (< 50°F (10°C)).

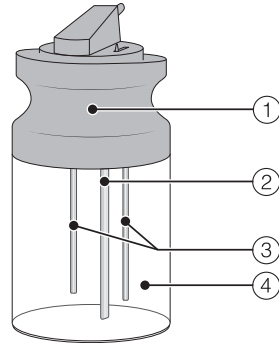

- ① Lid
- ② Milk intake tube
- ③ Sensor rod
- ④ Glass container

Filling and inserting the milk container

- Fill the milk container with milk up to a maximum of 2 cm below the rim. Seal the milk container with the lid.

Preparing drinks

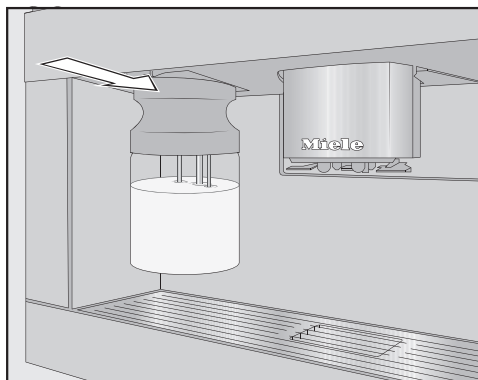

- Push the milk container back into the coffee machine until it clicks into place.

Useful tip: It is easier to remove the milk container with both hands.



Making a coffee drink

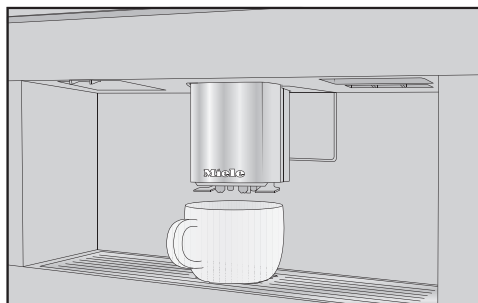

- Place a cup under the central spout.
- Tap the sensor button for the drink you want.

The drink will be dispensed from the central spout into the cup.

Cancelling a drink

- Tap the lit orange symbol on the control panel again.

When preparing drinks with several ingredients (e.g., latte macchiato) you can cancel each of the individual components prematurely.

- Tap OK when Stop appears on the display.

DoubleShot

Select the DoubleShot  function if you would like a particularly strong and aromatic coffee. In this case, more coffee beans will be ground and brewed halfway through brewing. The shorter extraction time means that fewer unwanted aromas and bitter compounds will be released.

DoubleShot can be activated for all drinks apart from “Ristretto” and “Long black”.

Making a DoubleShot ☉ of coffee

- Press the ☉ sensor button immediately before or after you start making a drink.

Dispensing starts and the ☉ sensor button lights up. 2 portions of coffee beans will be ground and brewed.

Making 2 portions (☐ sensor button)

You can dispense 2 portions of a drink into 1 large cup or into 2 cups at the same time.

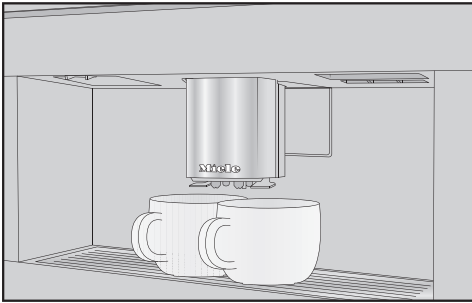

- Place a cup under each of the coffee dispensers in the central spout.
- Press the ☐ sensor button immediately before or after you start making a drink.

The ☐ sensor button lights up.

The dispensing starts and 2 portions of the desired drink will be dispensed.

Coffee jug

You can make several cups of coffee one after the other automatically with the Coffee Pot function (maximum of 1 litre).

The drinks menu is displayed.

Useful tip: Make sure that the bean and water containers have enough beans and water inside them before starting the Coffee Pot function.

- Place a sufficiently large container under the central spout.
- Touch the ☐ sensor button.
- Select Coffee Pot and confirm with *OK*.
- Select the number of cups you want (3 to 8).

Each portion of coffee will be ground, brewed, and dispensed individually. You can follow the process on the display.

Cancelling a drink

- Touch the ☐ sensor button.

Preparing drinks

Tea

The coffee machine is not intended for commercial or scientific purposes. Temperatures given are approximate and can vary depending on the ambient conditions.

When making tea, you can select from the following options:

- **Japanese Tea** is a high-quality green tea which boasts a fine, fresh, “green” taste.
Dispensed temperature:
approx. 150°F (65°C), brewing time:
approx. 1,5 minutes
- **White Tea** is a green tea where only the young buds of the tea plant are used and processed very gently. White tea has a particularly mild taste.
Dispensed temperature:
approx. 160°F (70°C), brewing time:
approx. 2 minutes
- **Green Tea** gets its green colour from the leaves of the tea plant. The tea leaves are either roasted or steamed depending on the region. Green tea can be infused multiple times.
Dispensed temperature:
approx. 175°F (80°C), brewing time:
approx. 2,5 minutes
- **Black Tea** gets its dark colour and characteristic taste from the fermentation of tea leaves. Black tea can be enjoyed with a little lemon or milk.
Dispensed temperature:
approx. 210°F (97°C), brewing time:
approx. 3 minutes

- **Chai Latte** has its origins in traditional Ayurveda medicine as a black tea with typically Indian spices and milk. The milk mellows the spices and tops off the flavour experience.
Dispensed temperature:
approx. 210°F (97°C)°C, brewing time: approx. 3 minutes
- **Herbal Tea** is an aromatic infusion drink made up of dried leaves or fresh parts of plants.
Dispensed temperature:
approx. 210°F (97°C), brewing time:
approx. 8 minutes
- **Fruit Tea** is made from dried pieces of fruit and / or parts of plants, e.g., rose hip. The taste of the drink varies according to which plants are used and how they are blended. Lots of fruit teas are also flavoured.
Dispensed temperature:
approx. 210°F (97°C), brewing time:
approx. 8 minutes

The type of tea selected determines the preset temperature. The respective dispensing temperatures are the ones that Miele recommends for making the types of tea concerned.

You can adjust the dispensing temperatures used for the individual teas by customizing the brewing temperature (see “Parameters – Brewing temperature”). A temperature increment of approximately 36°F (2°C) makes a noticeable difference.

Whether you use loose tea leaves, blended tea, or tea bags depends on your own personal preference.

Follow the instructions for making tea on the tea packaging.

The amount of tea required varies from one type of tea to another. Always follow the recommendations of the manufacturer on the packaging or of the retailer. You can adjust the amount of water according to the type of tea and the size of the cup (see “Portion size”).

TeaTimer

You can use the **TeaTimer** function to start a minute minder when making tea. There is a preset brewing time for the type of tea selected. You can adjust the preset brewing time (up to a maximum of 14:59 minutes). The changed brewing time is saved.



While the brewing time is counting down, you can continue to use the coffee machine as normal. After the brewing time has elapsed, an audible signal will sound and the  symbol will flash.

Setting TeaTimer

You can choose between the following options:

- **Automatic:** The **TeaTimer** starts automatically once the water has been dispensed.
- **Manual:** Once the water has been dispensed, you have the option of starting the **TeaTimer**.

The drinks menu is displayed.

- Touch the  sensor button.
- Select **Settings**  | **TeaTimer**.

- Select the setting you want and confirm with **OK**.

Making tea

Tap the  sensor button to access the menu containing the various types of tea.

The drinks menu is displayed.

- Pour loose tea into a tea filter or similar or take a tea bag out of the packet.
- Place the tea filter or the tea bag in the tea cup.
- Place the tea cup under the central spout.
- Tap .
- Select the type of tea you want and confirm your choice with **OK**.

Hot water will be dispensed into the cup.

If the **TeaTimer | Automatic** setting has been selected, the minute minder for the brewing time will start running once the water has been dispensed.

Starting the TeaTimer manually

TeaTimer appears in the display as soon as the water has been dispensed.

- Touch **OK**.

The editor will open with a suggested time.

- Change the brewing time if required and confirm with **OK**.

After the brewing time has elapsed, a buzzer will sound and the  symbol will flash.

Preparing drinks

- Remove the tea filter or tea bag when the desired brewing time has elapsed.

Tea pot

The Tea Pot function allows you to make a large quantity of tea (maximum of 1 litre). The type of tea selected determines the preset temperature.

The drinks menu is displayed.

Useful tip: Make sure that the water container has enough water inside it before starting the Tea Pot function.

- Place a sufficiently large container under the central spout.
- Tap the ☞ drinks sensor button.
- Select Tea Pot.
- Select the type of tea and number of cups you want (3 to 8).

Cancelling a drink

- Touch the ☞ sensor button.

Dispensing warm or hot water

You can choose between the following options:

- hot water at approx. 90°C
- warm water at approx. 65°C

The drinks menu is displayed.



- Place a suitable container underneath the central spout.
- Touch the ☞ sensor button.
- Choose between warm or hot water.
- Confirm with OK.

Dispensing will start.

The Expert Mode function allows you to change the portion size while the drink is being made. The setting will **not** be saved and will only apply to the current drink.

Switching Expert Mode on and off

The drinks menu is displayed.



- Touch the  sensor button.
- Select Settings  | Expert Mode.
- Select the option you want.
- Confirm with *OK*.

The setting is now saved.

Expert Mode: changing the portion size

The drinks menu is displayed.

The portion size can only be changed during the individual preparation stages.

If you select DoubleShot  or 2 portions , Expert mode cannot be used to change the portion size.

- Select a drink.

Dispensing will start. You can adjust the portion size while it is being dispensed, e.g., individually change the amount of hot milk, milk froth, and espresso for a latte macchiato.

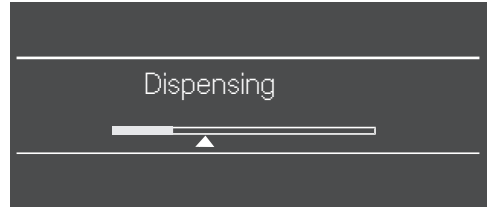

- Move the indicator (small triangle) across the navigation area according to the portion size you want.

Grinder setting

The grinder setting determines the contact time between the ground coffee and the water, known as the extraction time. When the ideal grinder setting is selected, the machine dispenses a perfect cup of coffee with a fine, hazelnut-brown crema.

The grinder setting you select will be used for all coffee drinks.

There are various ways to tell whether the coffee grinder is set correctly.

The grinder setting is **too coarse** if the coffee or espresso is watery and tastes acidic. The crema is very pale.

Set a finer grinder setting.

The grinder setting is **too fine** if the coffee or espresso tastes too bitter and the crema is dark brown.

Set a coarser grinder setting.

Only adjust the grinder one setting at a time.

Start making a new drink to grind beans again. Adjust the grinder setting one setting at a time again.

Adjusting the fineness of grind

The slide control for adjusting the fineness is located on the top left behind the water container.

- Open the appliance door.
- Remove the water container.

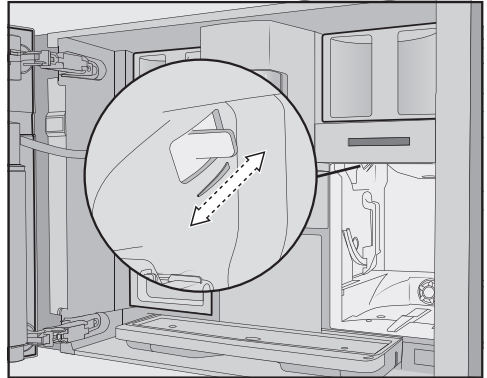

- Push the slide control a maximum of one setting forward (for finer grinding) or one setting backward (for coarser grinding).
- Replace the water container.
- Close the appliance door.
- Make one cup of coffee.

After this, you can adjust the grinder setting again.

Displaying and changing parameters

You can change the portion size for all drinks.

In addition, you can set the amount of coffee, brew temperature, and pre-brewing parameters for each coffee drink individually.

- Touch the  sensor button.
- Select a drink and confirm with *OK*.

The parameters that can be changed for this drink are displayed.

Once you have selected a drink, the current settings for the following appear: Amount of coffee, Brew temperature, and Pre-brewing.

The Portion size menu option is displayed in the first line. If you select Portion size and confirm with *OK*, the drink will be dispensed immediately.

- Select the parameter you want.
- Change the setting as required and confirm with *OK*.

The setting is now saved.

Portion size

The flavour of the coffee produced depends not only on the type of coffee, but also on the amount of water used. You can program the amount of water for all drinks (apart from the Coffee Pot function) to suit the size of your cups and / or the type of coffee you are using.

For coffee drinks that use milk, you can not only set the amount of espresso or coffee but also the amount of milk or milk froth to be dispensed with these drinks.

A maximum portion size can be programmed for each type of drink. Dispensing stops once this has been reached. The maximum possible portion size is then saved by the machine for this type of drink.

If the water container becomes empty whilst making a drink, the coffee machine will stop programming the portion size. The portion size will **not** be saved.

Changing the portion size

- Place a cup under the central spout.
- Select Portion size and confirm with *OK*.

The desired drink will be made and *Save* will appear in the display.

- When the container is filled to the desired level, tap *OK*.

If you want to change the portion size for coffee made with milk, the ingredients which make up the drink will be saved one after the other while the drink is being made.

- When the quantity for each ingredient reaches the desired level, tap *OK*.

The programmed portion size will now be dispensed every time that particular drink is selected.

Parameters

Useful tip: For the drinks pictured on the control panel, you can change the portion size by pressing and holding the button down while the drink is being dispensed. To do this, keep the drinks button pressed until the machine starts dispensing. During dispensing, *Save* appears in the display.

Quantity of coffee

The coffee machine can grind and brew 7,5–12,5 g of coffee beans per cup. The greater the quantity, the stronger the coffee.

The quantity of coffee is **too low** if the espresso or coffee lacks body.

Increase the quantity of coffee so that more ground coffee is brewed.

The quantity of coffee is **too high** if the espresso or coffee tastes bitter.

Decrease the quantity of coffee so that less ground coffee is brewed.

Brewing temperature

The brewing temperature must be adapted to the roast of the beans you are using. This is crucial whether you are making espresso or coffee.

Several types are sensitive to high brewing temperatures, resulting in an impaired taste. If your coffee tastes bitter, the brewing temperature you have selected might be too high.

Espresso is usually brewed at higher temperatures.

You can also adjust the brewing temperature for making tea and dispensing warm and hot water.

Pre-brewing the ground coffee

When the pre-brewing function is turned on, the ground coffee is first moistened with a little hot water. The ground coffee swells a little. The remaining amount of water is then pressed through the moistened coffee grounds shortly after. If your coffee tastes too bland and you want to add some spice and richness, try the “Pre-brewing” function. Depending on the type of coffee used, pre-brewing can intensify the taste.

You can set a short or long duration for pre-brewing or turn the “Pre-brewing” function off completely.

Useful tip: We particularly recommend using the “Pre-brewing” function to make coffee.

In addition to the Miele drinks menu (Miele profile), you can create individual profiles to cater for different tastes and preferences.

Within the profile, you can adjust the portion sizes and parameters individually for all drinks.

The name of the current profile is shown in the top left of the display.



Creating a profile

- Touch the  sensor button.

The Profiles menu opens.

- Select **Create profile** and confirm with **OK**.

The editor will open in the display.

- Enter the profile name:
 - To enter a character, highlight the one you want and confirm your choice with **OK**.
 - To delete a character, touch the  sensor button.
 - To save the name, select the check  and confirm with **OK**.

The profile has been created.

Changing drinks within a profile

When you change the parameters of a drink within a profile, these settings only apply to the active profile. The settings for drinks contained within other profiles remain unaffected.

- Select the profile you want.

The name of the selected profile is shown in the top left of the display.

You can now change the drinks individually.

Making drinks stored in a profile

- Touch the  sensor button.
- Select the profile you want.
- Select the drink you want.

The machine starts dispensing the drink.

Editing profiles

Once you have created at least one profile, you can rename, delete, or set profiles in the Profiles menu.

- Select **Edit** and confirm with **OK**.

You can now edit the selected profile.

Setting when the profile should change

You can choose between the following options:



- **Manual:** The selected profile will remain active until you select another one.
 - **After each use:** The machine will revert to the Miele profile whenever a drink is dispensed.
 - **When turned on:** The Miele profile will be displayed whenever the coffee machine is switched on, regardless of which profile was selected before the machine was last switched off.
- Select **Change profile** and confirm with **OK**.

- Select the option you want and confirm with **OK**.

Profiles

Changing the name

This option can only be selected if a profile has been allocated in addition to the Miele standard profile.

- Select **Change name** and confirm with *OK*.
- Change the name as required:
 - To delete a character, touch the  sensor button.
 - To enter a new character, highlight the one you want and confirm your choice with *OK*.
 - To save the modified name, select the check  and confirm with *OK*.

Deleting a profile

This option can only be selected if a profile has been allocated in addition to the Miele standard profile.

- Select **Delete profile** and confirm with *OK*.
- Select the profile you wish to delete.
- Select **Yes** and confirm with *OK*.

The profile will be deleted.

With MobileStart you can, for example, start making a drink via the Miele app.

You will only be able to use MobileStart if Miele@home has been set up for your coffee machine.

 **Danger of burning and scalding on the dispensing spouts.**

If liquids or steam are dispensed while the machine is unsupervised, persons may burn themselves if they place body parts under the central spout or touch hot components.

Ensure that no one, especially children, can be harmed if the machine is operated without supervision.

The pipework is not pre-warmed when the machine is switched on, meaning that the cup under the central spout is not filled with rinse water.

Milk is not cooled in the milk container. If you want to start making a drink with milk using the app, make sure that the milk is sufficiently cold (< 50°F (10°C)).

If the coffee machine is being operated manually, it cannot be operated via the app. Operation on the machine takes precedence.

To start making drinks remotely, MobileStart must be activated. Make sure that the coffee machine is ready to use, for example check that the water container is sufficiently filled. Place a sufficiently large, empty cup under the central spout.

MobileStart will be deactivated after 24 hours.

If you are making a drink with MobileStart, you will be notified of drink dispensing with acoustic and optical signals. These warning signals cannot be changed or switched off.

Switching MobileStart on and off

If you want to use Mobile Start, the Remote control option must be switched on.

The drinks menu is displayed.

- Touch the  sensor button.
- Select Mobile Start.
- Select the option you want and confirm with *OK*.



Once you have switched on Mobile Start, you can now start making a drink via the app. Follow the prompts to do this.

Settings

You can use the “Settings” menu to customize the coffee machine to suit your requirements.

Displaying and changing Settings

The drinks menu is displayed.

- Touch the  sensor button.
- Select Settings  and tap **OK**.
- Select the menu option that you want to display or change.
- Confirm with **OK**.
- Change the setting as required and confirm with **OK**.

Some settings which can be found in the Settings menu are described in separate sections of the operating instructions.

Language

You can select the language and, if applicable, your location for all display text.

Useful tip: If you select the wrong language by mistake, you can find the Language option again via the  symbol.

Time of day

Display (time display)

Select how you want the time of day to show in the display when the coffee machine is switched off:

- **On:** The time is always visible in the display.

- **Off:** The time is not visible in the display.
- **Night dimming:** To save energy, the time is displayed from 5:00 am to 11:00 pm only.

Clock format

- 24-hour display (24 h)
- 12-hour display (12 h)

Setting

Set the hours and the minutes.

If the coffee machine has been connected to a Wi-Fi network and signed into the Miele app, the time will be synchronized based on the location setting in the Miele app.

Date

Set the date.

Timer

The coffee machine has 2 timers offering the Turn on at and Turn off at timer functions.

You can allocate the individual timer functions to different days of the week.

On at

The coffee machine switches on at a particular time, e.g., in the morning for breakfast.

The coffee machine will **not** switch on at the required time if you have activated the system lock. The timer settings are deactivated.

Once the coffee machine has come on automatically **three times** at the set time without any drinks being dispensed, it will stop switching on automatically. This prevents the coffee machine from switching itself on unnecessarily; for example, while you are on vacation.

The programmed times will, however, remain in the memory and will be reactivated after manually switching the machine on again.

If you have set the time to be displayed while the machine is turned off (Show | On or Night dimming), the  symbol and the desired switch-on time will appear in the display 23:59 hours beforehand.

Off at

The coffee machine switches off at a particular time.

In the event of a longer absence, the programmed times will remain in the memory and will be reactivated when the machine is next switched back on manually.

Off after

The coffee machine switches off after a particular length of time if no sensor buttons have been pressed.

By default, the coffee machine switches off after 20 minutes.

You can change this to another time between 20 minutes and 9 hours.

TeaTimer

You can use the TeaTimer to start a minute minder when making tea (see “Making drinks – TeaTimer”).

Volume

You can set the volume of the audible signal and keypad tones (segment bar).

The welcome melody that plays when you tap the On / Off button  can be switched on or off.

Display brightness

You can set the display brightness (segment bar).

Lighting

You can change the brightness of the lighting while the coffee machine is switched on or off.

You can also specify how long the lighting should stay on for when the machine is switched off (adjustable between 15 minutes and 9 hours).

Info (display information)

You can display the number of drinks dispensed so far and how many more can be dispensed until the maintenance programs have to be run.

Altitude

If the coffee machine is installed at high altitudes, the lower air pressure will cause the water to boil at a lower temperature. You can set the local altitude of the machine to ensure that the correct temperatures are achieved.

Performance Mode

You can select the appropriate Performance mode for how you use your machine. Eco Mode is set by default.

Settings

Eco Mode

Eco mode is an energy-saving mode. The system does not heat up until someone starts making a drink.

Barista Mode

This Performance mode has been optimized for unadulterated coffee enjoyment. Users can enjoy coffee-based drinks without any delay as the coffee machine remains heated to the brewing temperature. This mode consumes more energy than Eco mode.

Latte Mode

This Performance mode has been optimized for preparing milk. Milk-based drinks can be prepared within a much shorter space of time. This mode consumes more energy than Eco mode and Barista mode.

Party Mode

This Performance mode has been configured for the **occasional** intensive use of the coffee machine, e.g., for family get-togethers.

Clean the coffee machine thoroughly after intensive use, particularly the milk pipework. It may be necessary to descale the coffee machine and degrease the brew unit.

Please note the following information about Party mode:

- The pipework is rinsed much less frequently or not at all. The milk pipework is not rinsed until around 1 hour after milk was last dispensed.

- Cleaning status messages or cleaning prompts are suppressed and delayed until the machine is next switched on.
- The Turn off at and Turn off after timers are deactivated. The coffee machine switches off 6 hours after the last sensor button was pressed.
- The cup light remains permanently switched on at the maximum brightness level for as long as the coffee machine stays switched on.

Water hardness

Program the coffee machine to the water hardness level of your area so that it functions correctly and does not get damaged.

Your local water authority will be able to tell you the hardness of the water in your area.

If you are using bottled drinking water, e.g., mineral water, select settings according to the calcium content. The calcium content is given on the label of the bottle in mg/l Ca^{2+} or ppm (mg Ca^{2+} /l).

Do not use carbonated water.

The hardness level is set to 21°dH by default.

Settings

Water hardness		Calcium content mg/l Ca ²⁺ or ppm (mg Ca ²⁺ /l)	Setting
°dH	mmol/l		
1	0.2	7	1
2	0.4	14	2
3	0.5	21	3
4	0.7	29	4
5	0.9	36	5
6	1.1	43	6
7	1.3	50	7
8	1.4	57	8
9	1.6	64	9
10	1.8	71	10
11	2.0	79	11
12	2.1	86	12
13	2.3	93	13
14	2.5	100	14
15	2.7	107	15
16	2.9	114	16
17	3.0	121	17
18	3.2	129	18
19	3.4	136	19
20	3.6	143	20
21	3.8	150	21
22	3.9	157	22
23	4.1	164	23
24	4.3	171	24
25	4.5	179	25
26	4.6	186	26
27	4.8	193	27
28	5.0	200	28
29	5.2	207	29

Water hardness		Calcium content mg/l Ca ²⁺ or ppm (mg Ca ²⁺ /l)	Setting
°dH	mmol/l		
30	5.4	214	30
31	5.5	221	31
32	5.7	229	32
33	5.9	236	33
34	6.1	243	34
35	6.3	250	35
36	6.4	257	36
37–45	6.6–8.0	258–321	37–45
46–60	8.2–10.7	322–429	46–60
61–70	10.9–12.5	430–500	61–70

Useful tip: If your water hardness is > 21°dH (3.8 mmol/l), we recommend using bottled drinking water instead (< 150 mg/l Ca²⁺). This will mean your coffee machine will need to be descaled less often and there will be less impact on the environment because less descaling agent will be used.

System lock

You can lock the coffee machine to prevent it from being used by unauthorized persons, such as children.

When the system lock is activated, the settings for the Turn off after timer are deactivated. The coffee machine will **not** switch on at the time set.

Temporarily deactivating the system lock

- Press and hold OK for 6 seconds.

Settings

The system lock is reactivated when the coffee machine is next switched off.

Miele@home

The following points may appear under Miele@home:

- **Set up:** This option only appears if the coffee machine has never been connected to a WiFi network or if the network configuration has been reset.
- **Deactivate*/Activate*:** The settings for the WiFi network are retained, but the network is switched on or off.
- **Connection status*:** Information about the WiFi connection is displayed. The symbols indicate the strength of the connection.
- **Set up again*:** The settings for the current WiFi network will be reset. The Wi-Fi connection will be set up again.
- **Reset*:** The Wi-Fi is switched off and the settings for the current Wi-Fi network will be reset.

The network configuration should be reset whenever the coffee machine is being disposed of or sold, or if a used coffee machine is being put into operation. This is the only way to ensure that all personal data has been removed and the previous owner will no longer be able to access the coffee machine.

* This menu option appears if Miele@home has been set up and the coffee machine has – where applicable – been connected to a Wi-Fi network.

Remote control

The remote control option appears when the coffee machine is connected to a Wi-Fi network.

You can change the coffee machine settings, for example, in the Miele app when remote control is switched on. To start making a drink via the app, MobileStart also needs to be activated.

The remote control function is switched on by default.

RemoteUpdate

The “RemoteUpdate” menu option is only displayed and can only be selected if the requirements for using Miele@home have been met.

The RemoteUpdate function allows the software on your coffee machine to be updated. If an update is available for your coffee machine, it will automatically download it. Updates will not be installed automatically. They must be initiated manually.

If you do not install an update, you can continue to use your coffee machine in the usual way. However, Miele recommends installing updates.

Activating / deactivating

The RemoteUpdate function is activated by default. Available updates will be downloaded automatically but will only be installed if you initiate installation manually.

Deactivate RemoteUpdate if you do not want any updates to be downloaded automatically.

Running a RemoteUpdate

Information about the content and scope of an update is provided in the Miele app.

A message will appear in your coffee machine display if a software update is available.

You can install the update immediately or postpone this until later. When the coffee machine is switched on again, you will be reminded about the update.

Deactivate RemoteUpdate if you do not want to install the update.

The update may take several minutes.

Please note the following information about the RemoteUpdate function:

- You will only receive a message when an update is available.
- Once an update has been installed, it cannot be undone.
- Do not switch the coffee machine off during the update. Otherwise, the update will be aborted and will not be installed.
- Some software updates can only be carried out by Miele Service.

Software version

The “Software version” menu option is intended for Miele Service. You do not need this information for domestic use.

Showroom program (demo mode)

Do not activate this function for domestic use.

The Demo Mode | Demo Mode function enables the coffee machine to be demonstrated in shops or showrooms. In this mode, the machine lights up but no drinks can be prepared and no maintenance programs can be run.

You can activate demo mode without commissioning the appliance for the first time. Switch the coffee machine on and off again. Press the ↵ button for 5 seconds straight away. Demo mode is activated.

Factory default settings

You can reset the coffee machine to its factory default settings.

The following will **not** be reset:

- the number of drinks dispensed and the appliance status (No. of portions until appliance needs descaling, ... brew unit needs degreasing)
- language
- time and date
- profiles and the associated drinks
- Miele@home

Cleaning and care



Risk to health due to inadequate cleaning.

Heat and moisture inside the coffee machine can cause coffee residues to become mouldy and / or milk residues to go off and pose a risk to health.

Carefully clean the coffee machine regularly.

Overview of cleaning intervals

Recommended frequency	What do I have to clean / maintain?
Daily (at the end of the day)	Milk container and lid
	Milk valve
	Water container
	Drip tray cover
	Drip tray and grounds container
Once a week (more often if heavily soiled)	Central spout
	Cup rim sensor
	Interior
	Brew unit
	Drip tray
	Appliance front
Once a month	Remove and clean the milk valve
	Bean container
As and when required / after prompt appears in display	Milk pipework (using the cleaning agent for milk pipework)
	Degrease the brew unit (using cleaning tablets)
	Descale the appliance

Cleaning by hand or in the dishwasher

The brew unit is **not** dishwasher-safe.

Only clean the brew unit by hand with warm water. **Do not use any cleaning agents.**

The following components must be cleaned **by hand only**:

- Stainless steel cover of the central spout
- Brew unit
- Bean containers and lids

 Risk of damage as a result of excessively high dishwasher temperatures.

Components may be ruined (e.g., may become warped) if washed in a dishwasher at temperatures higher than 55°C.

For dishwasher-safe components, always select dishwasher programs with a maximum temperature of 55°C.

Contact with natural dyes, such as those found in carrots, tomatoes, and ketchup, may discolour the plastic parts in the dishwasher. This discolouration does not affect the stability of the parts.

The following components are **dishwasher-safe**:

- Drip tray, lid, and grounds container
- Drip tray cover
- Central spout (without stainless steel cover)
- Milk container with lid
- Cup rim sensor
- Drip tray
- Maintenance container
- Water container

Cleaning and care

 Danger of burning and scalding on hot components or by hot liquids.

Components can become very hot during operation. Touching hot components can cause burning. The liquids and steam dispensed are very hot and can cause scalding.

Keep away from the area underneath the spouts when hot liquids and steam are being dispensed.

Always allow the coffee machine to cool down before cleaning it.

Please be aware that water in the drip tray can also be very hot.

 Risk of damage due to moisture ingress.

The steam from a steam cleaner could reach electrical components and cause a short circuit.

Do not use a steam cleaner to clean the coffee machine.

It is important to clean the appliance regularly, as the used coffee grounds will soon go mouldy. Milk residues can go off and can block the milk pipework.

Unsuitable cleaning agents

Contact with unsuitable cleaning agents can alter or discolour the external surfaces. All surfaces are susceptible to scratching. Scratches on glass can in some circumstances lead to breakage.

Remove any residual cleaning agent immediately. Make sure you remove any spillages or splashes of descaling agent immediately.

To avoid damaging the surfaces, do not use:

- cleaning agents containing soda, ammonia, acids, or chlorides
- solvent-based cleaning agents
- cleaning agents containing descaling agents (unsuitable for cleaning the front of the appliance)
- stainless steel cleaners
- dishwasher cleaners (unsuitable for cleaning the front of the appliance)
- glass cleaners
- cleaning agents for ceramic cooktops
- oven cleaners
- abrasive cleaning agents, e.g., scouring powder, scouring cream, bath bricks
- hard, abrasive brushes or sponges, e.g., pot scourers, brushes, or sponges which have been previously used with abrasive cleaning agents
- eraser blocks
- sharp metal scrapers
- steel wool or stainless steel wire scourers

Cleaning the drip tray and grounds container

 Danger of burning and scalding on hot components or by hot liquids. Components can become very hot during operation. Touching hot components can cause burning. The liquids and steam dispensed are very hot and can cause scalding.

If the pipework has just been rinsed, wait a while before removing the drip tray.

Please be aware that water in the drip tray can also be very hot. Do not touch hot components.

Clean the drip tray and grounds container **every day** to avoid unpleasant smells and mildew.

A prompt will appear in the display when the drip tray and / or the grounds container is full and needs to be emptied. Empty the drip tray **and** the grounds container. It is not necessary to take the lid off the drip tray in order to empty it.

Useful tip: If the drip tray is heavily soiled, clean it with a brush before placing it in the dishwasher.

- Open the appliance door.

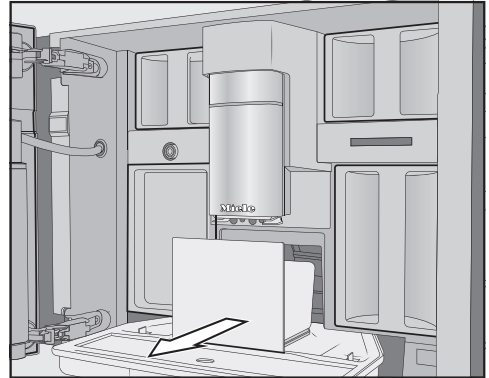

- Remove the drip tray and grounds container from the machine.
- Empty the grounds container after removing it from the drip tray.

The grounds container may contain a small amount of water from rinsing as well as the leftover coffee grounds.

Taking the drip tray apart

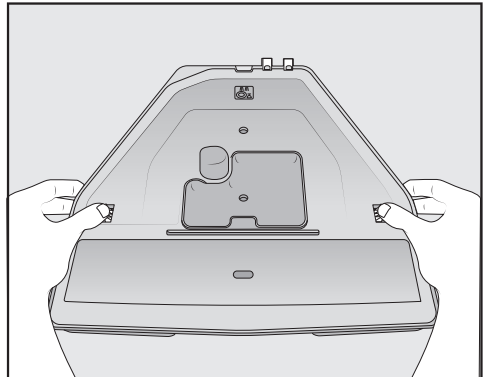

The orange clips are not removable.

- Take the lid off the drip tray as follows: press the orange clips outward on both sides to release the lid. Remove the lid.

Cleaning and care

- Clean the drip tray, lid, and grounds container in the dishwasher or wash them by hand using warm water and a little dish detergent.
- Dry all parts.
- Clean the drip tray recess inside of the coffee machine.

Cleaning contacts

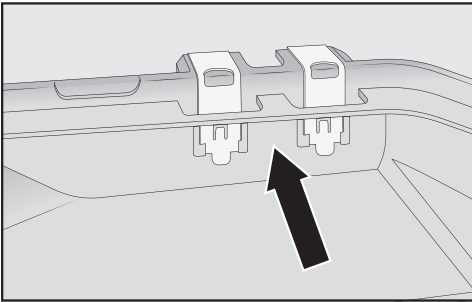

- Clean the contacts (metal discs) and the space between them carefully, e.g., using a brush. Dry all parts thoroughly.

The contacts will not be able to detect that the drip tray is full if they are damp or dirty. Check the contacts and the area around them once a week.

Reassembling the drip tray

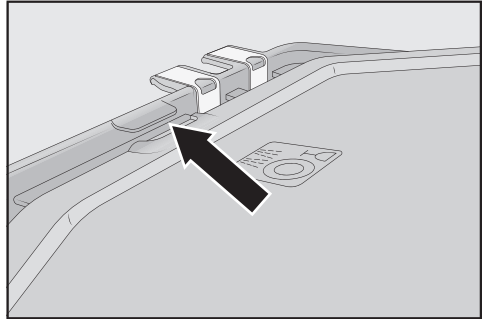

- Attach the drip tray lid as follows: slide the lid under the lug next to the contacts and apply pressure to the lid until the catches at the sides audibly click into place.

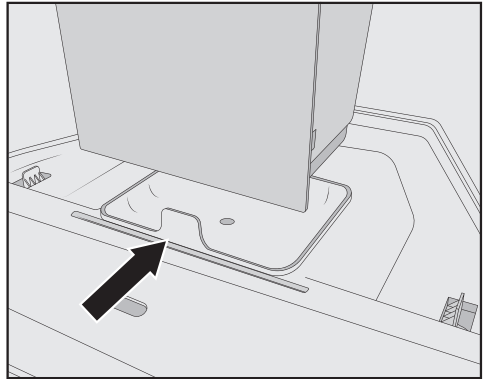

- Place the grounds container on the lid.
- Push the drip tray and grounds container back into the coffee machine. Close the appliance door.

Cleaning the drip tray cover

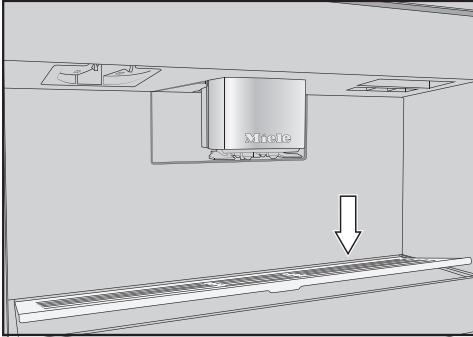

- Remove the drip tray cover: to do this, push down on the rear edge of the cover so that the front lifts up and can be easily removed.
- The drip tray can be cleaned in the dishwasher, or by hand using warm water and a little dish detergent.
- Dry the drip tray cover.
- Replace the drip tray cover.

Cleaning the water container

Clean the water container by hand every day with warm water and a little dish detergent. You can clean the water container in the dishwasher once a week.

- Open the appliance door.
- Remove the water container.
- Clean and rinse the water container with clean water to remove any detergent residues. Dry the outside of the water container.

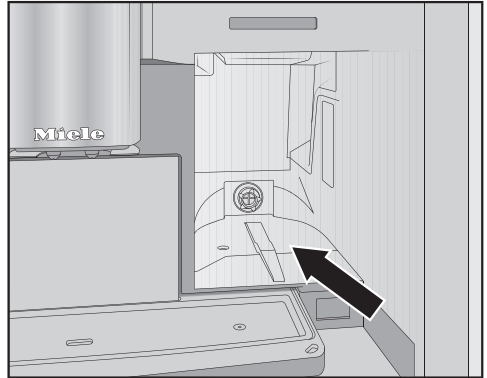

- Clean and dry the surface that the water container sits on.
- Fill the water container with fresh, cold drinking water.
- Push the water container all the way into the coffee machine until you feel a resistance. Close the appliance door.

Cleaning the central spout

Clean the central spout's stainless steel cover by hand only, using warm water and a little dish detergent.

With the exception of the stainless steel cover, all parts of the central spout should be cleaned in the dishwasher **once a week**. This will remove coffee deposits and milk residues effectively.

- Open the appliance door.
- Pull the central spout's stainless steel cover forwards to remove it. Then clean it.

Cleaning and care

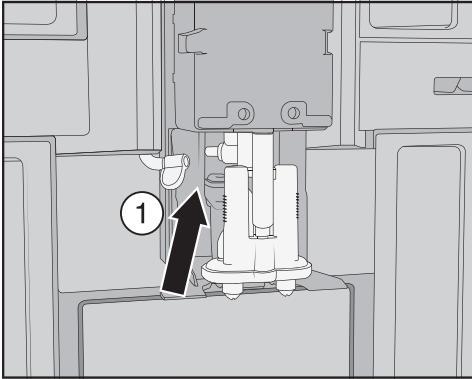

- Detach the milk pipework from the dispensing unit as follows: pull the tab ① to the left.

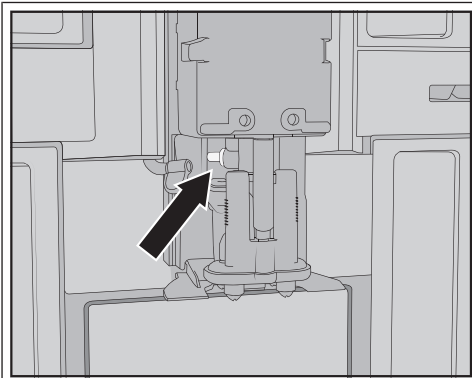

Do not remove the milk pipework connecting piece. If necessary, clean the connecting piece with the cleaning brush.

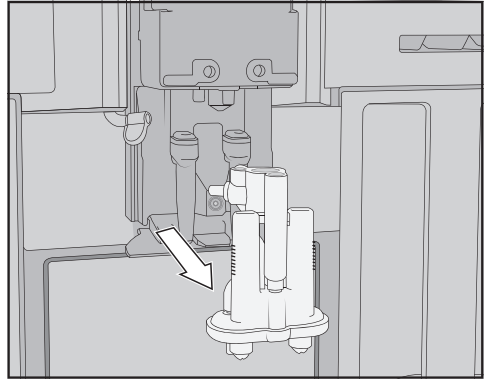

- Grip the dispensing unit by the sides and pull it down to remove it.

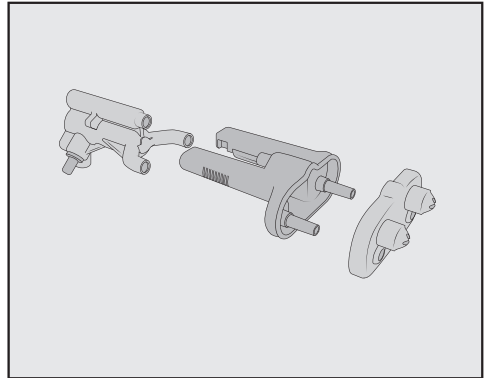

- Take the dispensing unit apart, separating it into 3 components: the Y-piece, the spouts, and the holder.
- Clean all parts thoroughly.



- Clean the area around the central spout with a damp cloth.

Reassembling the central spout

The dispensing unit is easier to reassemble if the individual parts are dampened with water beforehand.

Make sure that all parts are tightly connected to one another.

- Reassemble the dispensing unit. Press down firmly so that the spouts become securely connected to the holder.

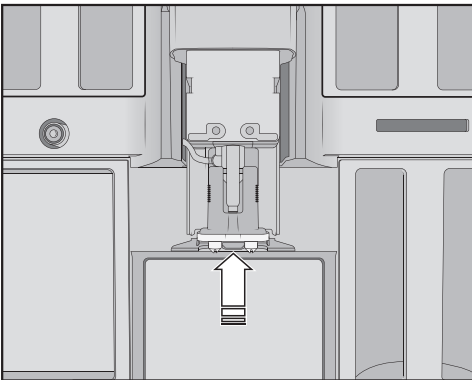

- Insert the dispensing unit into the coffee machine and connect the milk pipework.

- Refit the stainless steel cover.
- Close the appliance door.

Fit cover to main dispenser appears in the display.

- Confirm the message with OK.

Cleaning the cup rim sensor

The cup rim sensor is located at the bottom of the central spout.

Clean the cup rim sensor at least once a week and more often if heavily soiled.

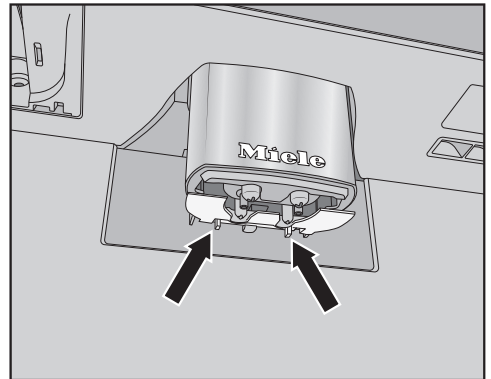

- Press the two retainers together (see arrows).

The cup rim sensor is released.

- The cup rim sensor can be cleaned in the dishwasher, or by hand using warm water and a little dish detergent.
- To refit the cup rim sensor, press it into the holder on the central spout from below.

Cleaning and care

Cleaning the milk container with lid

The milk container should be taken apart and cleaned every day after use.

Both the lid and the glass container can be cleaned in the dishwasher, or by hand using warm water and a little dish detergent.

- Remove and empty the milk container.

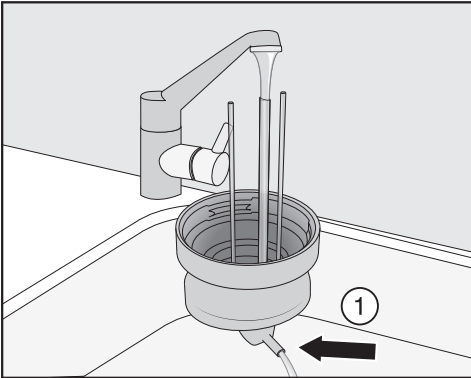

- Rinse the milk pipework in the lid under running water and then place the lid in the dishwasher.
- If no water runs out of the connecting piece ①, clean it with the cleaning brush.
- Clean the glass container.
- Dry all parts and especially the threads on the lid and on the glass with a clean cloth. Reassemble the milk container.

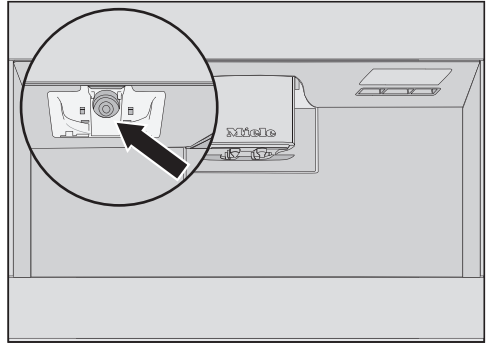

- Clean the milk container holder on the coffee machine with a damp cloth.

Cleaning the milk valve (daily)

The milk valve seal can be damaged by objects with sharp edges or similar.

Do not use any sharp-edged objects (such as knives) to clean the milk valve.

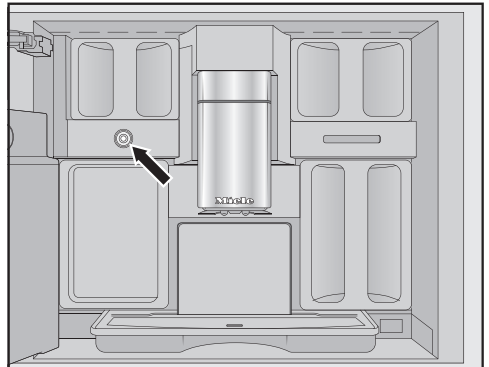

The milk valve is located under the bean container on the left-hand side.

If allowed to dry, milk residues can become encrusted on the stainless steel bolt. These crusty deposits are

difficult to remove. Therefore, it is important to carry out regular cleaning after preparing milk.

- Open the appliance door.
- Clean the milk valve with a damp sponge or microfibre cloth.
- Close the appliance door.

Removing and cleaning the milk valve (once a month)

If the following issues occur during milk preparation, the milk valve may be blocked: only hot milk is dispensed instead of milk froth, the milk sprays out. Clean the milk valve more often if necessary.

The milk valve cover should only be cleaned **by hand**.

- Open the appliance door.
- Remove the bean container on the left and the maintenance container.
- Remove the central spout's stainless steel cover.



- Remove the milk valve cover: press on the recessed grip to unlock the cover.

On the top right-hand side of the cover, you will find a pin for swivelling the cover out.

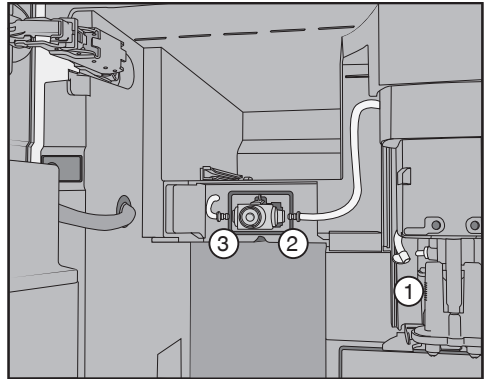

- Detach the milk pipework from the dispensing unit on the central spout ① and from the milk valve silicone seal (② and ③).
- Remove the milk pipework ① connecting the milk valve to the central spout.
- Disconnect the angular moulded hose from the round hose. Rinse the hoses under running water.

Do **not** remove the connecting pieces from the hoses.

Cleaning and care

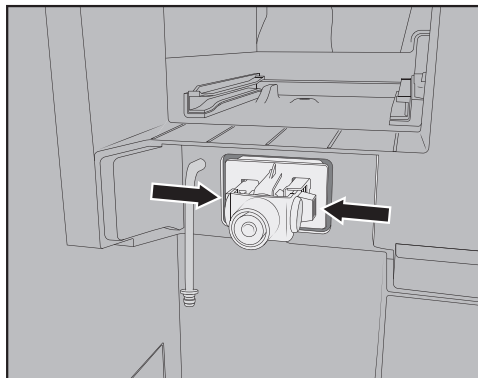

- Press the retainers on the left and right-hand sides of the milk valve holder and pull the holder forward to remove it.

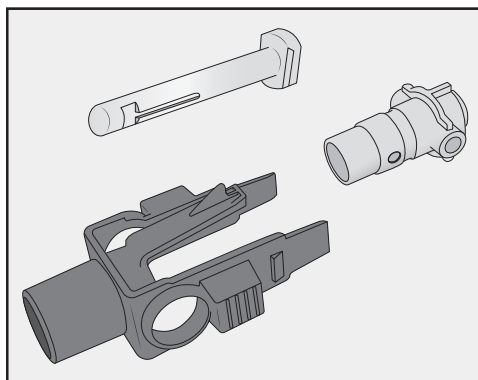

- Take the holder and silicone seal apart.

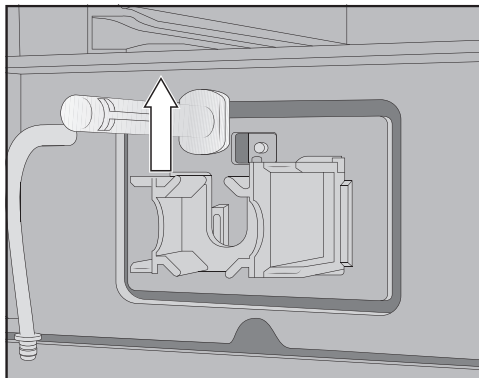

- Pull the stainless steel bolt upwards and out.
- Clean the individual components of the milk valve in the dishwasher.

Useful tip: If there are any dry milk residues on the front, soak the stainless steel bolt in warm water and a little dish detergent.

Installing the milk valve

- Insert the stainless steel bolt from above.
- Insert the silicone seal into the milk valve holder.

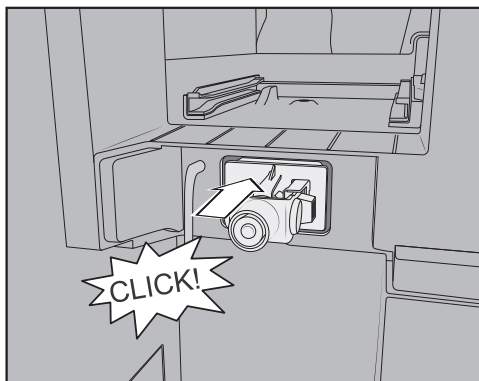

- Insert the holder and silicone seal until they audibly click into place.

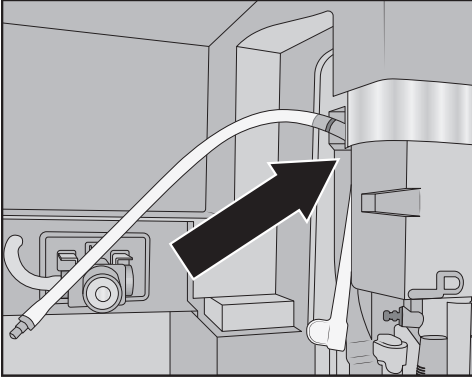

- Connect together the angular moulded hose and longer milk pipework. Start by attaching the moulded hose to the top of the central spout. The black connecting piece should be pointing to the rear.
- Then, connect the bottom end of the moulded hose to the dispensing unit.
- Insert the milk pipework into the milk valve on the left and right-hand sides. Push the connecting pieces into the silicone seal as far as they will go.
- Check that the milk pipework is snug against the housing and that the cover can be easily attached.

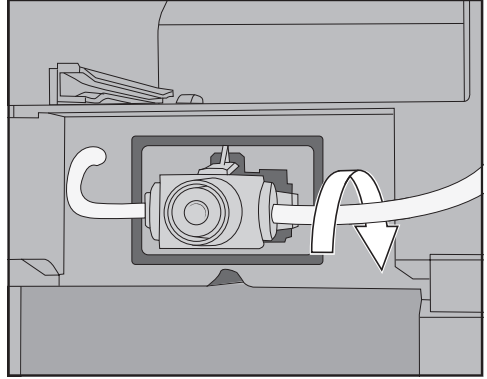

Useful tip: If necessary, turn the milk pipework towards the back at the connecting piece on the right-hand side.

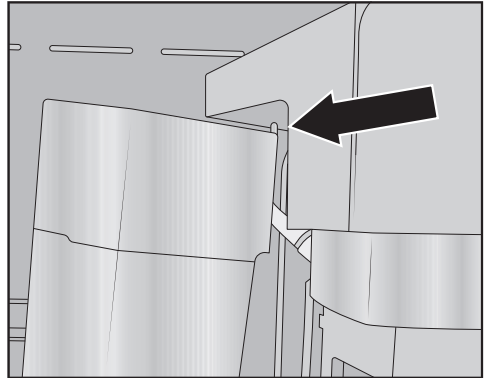

- Attach the milk valve cover as follows: insert the pin in the top right-hand corner and swivel the cover backwards until a proper fit is achieved.
- Push the left-hand bean container and maintenance container back into the coffee machine. Attach the central spout's stainless steel cover.
- Close the appliance door.

Cleaning and care

Cleaning the bean containers

 Risk of damage from incorrect use and cleaning.

Immersing the bean containers in liquids can result in malfunctions. If they are taken apart, bits may break off or the mechanism may no longer work properly once they are reassembled.

Do not disassemble the bean containers.

Do not immerse the bean containers in liquids, e.g., soapy water.

Coffee beans contain oils which can deposit on the walls of the bean containers and hinder the flow of the beans. This is why you need to clean the bean containers regularly with a soft cloth.

If required, you can clean the lids of the bean containers **by hand** with warm water and a little dish detergent. Dry the lids thoroughly before replacing them on the bean containers.

- Open the appliance door.
- Pull the left and right-hand bean containers out of the coffee machine.
- Clean the bean container wells inside the machine.

Useful tip: Use a vacuum cleaner to remove any coffee residues from the interior.

- Remove the lids and empty the bean containers.

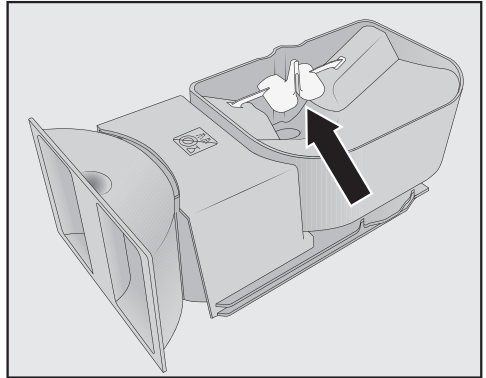

Do not remove the components for improving the flow of the beans (see arrow).

- Clean the bean containers and lids **by hand** using a slightly damp cloth. Dry all parts carefully before filling the bean containers with roasted coffee beans.
- Replace the lids and push the containers back into place in the coffee machine.
- Close the appliance door.

Cleaning the interior, inside of the appliance door, and drip tray

Clean the interior and front of the appliance as part of the normal cleaning process. For instance, if you remove the water container, use this as an opportunity to clean the area under the water container at the same time.

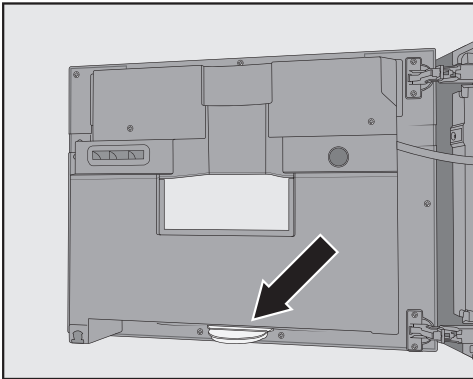

The drip tray is located at the bottom on the inside of the appliance door.

Remove and empty the drip tray on a regular basis. The drip tray is dishwasher-safe.

- Open the appliance door.
- Remove and clean the drip tray.
- Remove the following parts from the interior:
 - water container
 - drip tray
 - maintenance container
 - brew unit
 - bean containers

Useful tip: Use your vacuum cleaner to remove dry ground coffee residues.

- Clean the interior and the inside of the appliance door by hand with a slightly damp, clean sponge or microfibre cloth. After cleaning, wipe the interior and appliance door dry using a soft cloth.
- Put all the parts back in place, including the drip tray.
- Close the appliance door.

Cleaning the appliance front

If soiling is not removed promptly, it could cause the surface to alter or discolour.

Remove any soiling on the front of the appliance straight away.

Make sure that water cannot get behind the display.

Clean the front of the appliance after descaling. If possible, wipe up any spillages of descaling agent immediately.

Useful tip: Before cleaning the control panel, open the appliance door. This will prevent accidental operation.

- Clean the front of the appliance with a clean and slightly damp sponge cloth or microfibre cloth. After cleaning, wipe the surfaces dry using a soft cloth.

Useful tip: You can also use a Miele Microfibre Cloth to clean the front.

Cleaning and care

Maintenance programs

The coffee machine has the following maintenance programs:

- Rinse the appliance
- Rinse the milk pipework
- Clean the milk pipework
- Degrease the brew unit
- Descale the appliance

Carry out the relevant maintenance program when the prompt to do so appears in the display. You can also start maintenance programs at any time so that the coffee machine does not prompt mandatory cleaning at an inconvenient time.

Useful tip: To save you having to empty the drip tray too often, you can place the maintenance container under the central spout.

Opening the Maintenance menu

- Touch the  sensor button.

You can now select a maintenance program.

Rinse appliance

If you have made a coffee drink, the coffee machine will rinse the coffee pipework automatically before switching off.

You can also start the Rinse appliance function manually.

Rinse milk pipework

If you have made a drink with milk, the coffee machine will rinse the milk pipework automatically after a few minutes. You can also start the Rinse milk pipework function manually.

Cleaning the milk pipework

The milk pipework must be cleaned roughly once a week.

The Clean milk pipework maintenance program lasts for approx. 15 minutes.

- Touch the  sensor button.
- Select Clean milk pipework and tap OK.

The process will start and various messages will appear in the display.

- Follow the instructions in the display.

When Fill the water container with cleaning agent and lukewarm water up to the  symbol and insert. Close the door. **appears** in the display, proceed as follows.

Making a cleaning solution

For optimum cleaning results, we recommend using the Miele Cleaning Agent for milk pipework.

The cleaning agent for milk pipework has been specially developed for use with Miele Coffee Machines and prevents subsequent damage.

You can order the cleaning agent for milk pipework from the Miele online shop, from Miele Service, or from your Miele dealer.

- Add **2** sticks of the cleaning agent for milk pipework to the water container.

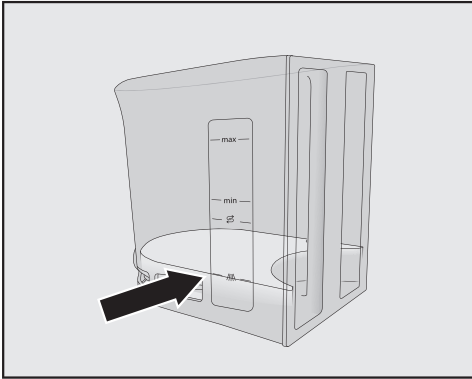

- Fill the water container to the /||\ mark with lukewarm water and stir the solution.

Follow the instructions for the mixing ratio carefully. Fill the water container with the specified amount of water. Otherwise, cleaning will be incomplete.

- Replace the water container in the coffee machine and close the door.
- Follow the instructions in the display.
- If prompted to do so in the display, rinse the water container thoroughly with clean water. Make sure that **no** cleaning agent is left in the water container. Fill the water container with drinking water.

The cleaning process is complete when the drinks menu appears.

Degreasing the brew unit and cleaning the interior

Depending on the natural oil content of the coffee used, the brew unit can become blocked quite quickly. It must

be degreased regularly in order to ensure aromatic coffee and trouble-free operation of the coffee machine.

It is recommended to use Miele Cleaning Tablets to clean the brew unit. These have been specially developed for degreasing the brew unit in Miele Coffee Machines and prevent subsequent damage.

The cleaning tablets are available to order from the Miele online shop, from Miele Service, or from your Miele dealer.

The maintenance program for degreasing the brew unit lasts for approx. 10 minutes.

You need 1 cleaning tablet for the maintenance program.

After 200 portions have been dispensed, a message prompting you to degrease the brew unit will appear in the display.

- Confirm the message with **OK**.

This message will keep being displayed until the brew unit has been degreased.

Degreasing the brew unit

- Touch the  sensor button.
- Select **Degrease the brew unit** and tap **OK**.

The maintenance program will then start.

- Follow the instructions in the display.

Remove the water container and the brew unit. Clean the interior of the machine. Rinse the brew unit by hand and refit it with a cleaning tablet in it. **appears in the display.**

Cleaning and care

Cleaning the brew unit and interior

The moving parts of the brew unit are lubricated. Cleaning agents will damage the brew unit.

Only clean the brew unit by hand with warm water. **Do not use any cleaning agents.**

To ensure good tasting coffee and to prevent a build-up of bacteria in the machine, remove and clean the brew unit under running water once a week.

- Open the appliance door.
- Remove the water container.

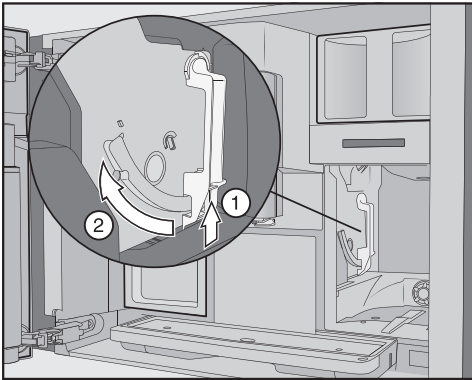

- Press the button under the handle of the brew unit ① and, while doing so, turn the handle forward ②.

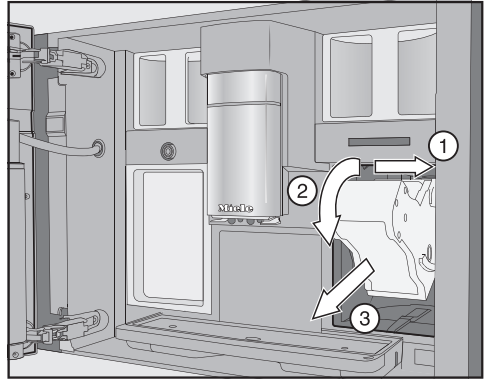

- Pull the brew unit to the side ① first and then pull out to the front ②. Tilt the brew unit forward ③ while doing so.

If you cannot remove the brew unit or can only do so with difficulty, the brew unit is not in the correct position (see “Frequently Asked Questions”).

When you have removed the brew unit, do **not** change the position of the handle on the brew unit. Otherwise the brew unit cannot be reinserted.

- Clean the brew unit **by hand under warm running water** without using cleaning agent or dish detergent.

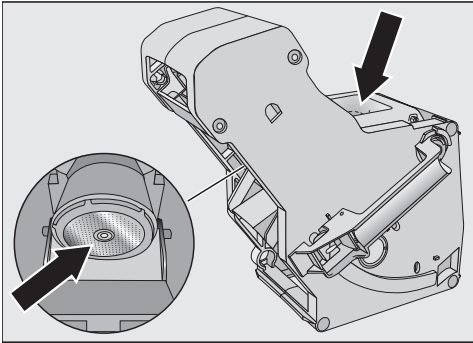

- Wipe any coffee grounds from the filters. One filter is located in the funnel and the other to the left of the funnel.

The process of removing the brew unit causes ground coffee to drop onto the drip tray.

- Remove the drip tray and clean the lid.
- Clean the interior of the coffee machine (see also “Cleaning and care – Removing the brew unit and cleaning it by hand”). Use your vacuum cleaner to remove dry ground coffee residues.

Dropping a cleaning tablet into the brew unit

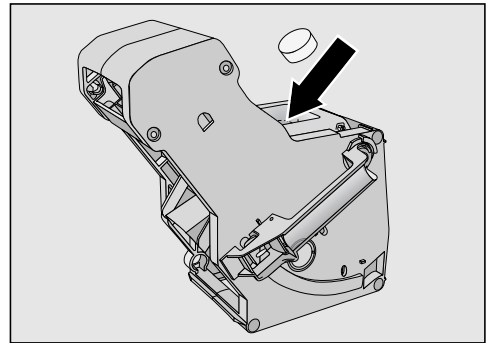

- Drop a cleaning tablet into the top of the brew unit (arrow).
- Push the brew unit containing the cleaning tablet back into the coffee machine.

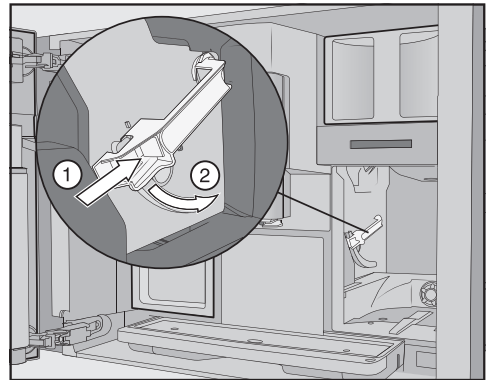

- Press the button under the handle of the brew unit ① and, while doing so, turn the handle backward ②.
- Push the water container and drip tray (plus grounds container) back into the coffee machine.
- Close the appliance door.
- Follow the further instructions given in the display.

Cleaning and care

The cleaning process is complete when the drinks menu appears.

Descaling the appliance

Risk of damage from splashes from the descaling solution.

Sensitive surfaces and / or natural floors can suffer damage.

Wipe up any spillages immediately when descaling.

Limescale builds up in the coffee machine through use. How often the appliance needs to be descaled will depend on the water hardness level in your area. Limescale must be removed regularly.

The appliance will guide you through the descaling process. Various messages will appear in the display, e.g., you will be prompted to empty the drip tray or fill the water container.

Descaling **must be carried out**. The process takes approx. 35 minutes.

The coffee machine will give you plenty of warning when it needs to be descaled. The remaining number of drinks that can be made before descaling will show in the display after each drink.

- Confirm the message with *OK*.

When the number of remaining portions reaches 0, the coffee machine will lock.

You can switch the coffee machine off if you do not want to carry out the descaling program at this point. You cannot make any drinks until the machine has been descaled.

Descaling after prompt appears in the display

Descaling the appliance will appear in the display.

- Confirm the message with *OK*.

The process will start.

- Follow the instructions in the display.

When Place 2 descaling tablets in the water container and fill it with lukewarm water up to the descaling symbol  and insert it. Close the door. **appears in the display**, proceed as follows.

Preparing the descaling solution

For optimum descaling results, it is recommended to use the Miele Descaling Tablets.

The descaling tablets have been specially developed for Miele Coffee Machines.

Other descaling agents, which contain other acids besides citric acid and / or other undesirable substances, such as chlorides, may cause damage to the product. Moreover, the descaling result required cannot be guaranteed if the descaling solution was not of the appropriate concentration.

The descaling tablets are available to order from the Miele online shop, from Miele Service, or from your Miele dealer.

You will need **2** descaling tablets.

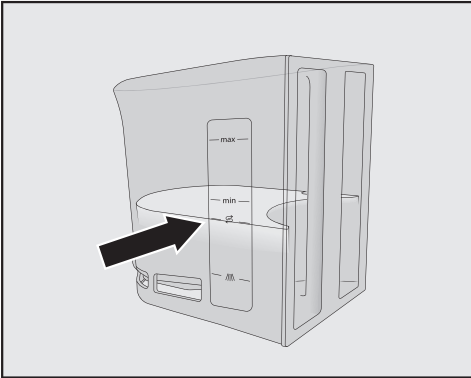

- Add **2** descaling tablets to the water container.
- Fill the water container to the **S** mark with lukewarm water.

Follow the instructions for the mixing ratio carefully. Fill the water container with the specified amount of water. Otherwise, descaling will be incomplete.

Carrying out descaling

- Reinsert the water container.
- Follow the further instructions given in the display.

When Fill the water container up to the **S** symbol and insert. Close the door. **appears** in the display:

- Remove the water container and rinse it thoroughly with clean water. Ensure that **no** descaling solution residue remains in the water container. Fill the water container with drinking water.

The descaling process is complete when the drinks menu appears.

Frequently Asked Questions

With the help of the following guide, minor faults in the performance of the machine, some of which may result from incorrect operation, can be remedied without contacting the Service Department. This will save you time and money because you won't need a service call.

This guide may help you find the reason for the fault and help you correct it.

Messages in the display

Fault messages must be confirmed with *OK*, otherwise the message may reappear in the display even though the problem has been remedied.

To address the fault, follow the instructions on the display.

If the fault message appears in the display again, contact Miele Service.

Problem	Possible cause and solution
F1, F2, F80, F82 F353, F354	There is an internal fault. ■ Switch the coffee machine off. Wait for approximately 1 hour before switching the machine back on again.
F74, F77 F225, F226 F235, F353, F354	There is an internal fault. ■ Switch the coffee machine off. Wait for approximately 2 minutes before switching the machine back on again.

Frequently Asked Questions

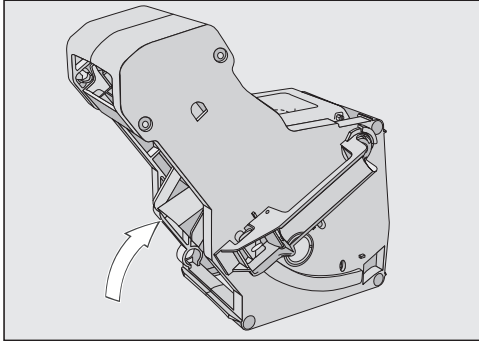
Problem	Possible cause and solution
<p>F73 or Check the brew unit</p>	<p>The brew unit cannot be positioned correctly in the start position or is soiled. It is not possible to press the ground coffee.</p> <ul style="list-style-type: none">■ Check whether you can remove the brew unit.■ If you can remove the brew unit, rinse it under running water.  <ul style="list-style-type: none">■ Push the coffee ejector of the brew unit into the correct start position (see image).■ Replace the water container in the coffee machine and close the door. Do not insert the brew unit. Switch the coffee machine on. <p>This will initialize the brew unit drive and put it back into the start position.</p> <ul style="list-style-type: none">■ When Insert the brew unit appears in the display, put the brew unit back in the coffee machine. Close the appliance door.■ If you cannot remove the brew unit, switch the coffee machine off. Wait for approximately 2 minutes before switching the machine back on again.

Frequently Asked Questions

Problem	Possible cause and solution
<p>A maintenance program is prematurely aborted and the following appears in the display: Push the water container in until it engages.</p>	<p>The water container has not been filled and inserted correctly.</p> <ul style="list-style-type: none"> ■ Check that you have filled to the correct mark. <p>The symbols marked on the water container indicate the amount of water required for the</p> <p>Descalc the appliance: ☞ and Clean milk pipework: ☞ maintenance programs.</p> <ul style="list-style-type: none"> ■ Fill the water container up to the relevant mark and restart the process.
<p>F233</p>	<p>The cup rim sensor is not inserted or is incorrectly inserted.</p> <p>If the central spout is moving upwards and the cup rim sensor is bumped, e.g., with a cup, the cup rim sensor loses its reference position.</p> <ul style="list-style-type: none"> ■ Confirm the message with <i>OK</i>. ■ Refit the cup rim sensor. <p>Cup rim detection remains inactive and the central spout stays in the top position until the coffee machine is next switched on. Cup rim detection is reinitialized during the next switch-on operation.</p>
<p>F 307 or Remove the milk valve and clean it</p>	<p>The milk valve is faulty.</p> <ul style="list-style-type: none"> ■ Remove and clean the milk valve (see “Cleaning and care – Removing and cleaning the milk valve”).

Frequently Asked Questions

Unusual performance of the coffee machine

Problem	Possible cause and solution
<p>The display remains dark when the coffee machine is turned on using the On / Off button ①.</p>	<p>The On / Off button ① was not held for long enough.</p> <ul style="list-style-type: none"> ■ Touch and hold the On / Off button ① for at least 3 seconds.
	<p>The plug is not inserted in the socket correctly.</p> <ul style="list-style-type: none"> ■ Insert the plug into the socket.
	<p>The circuit breaker has tripped because the coffee machine, voltage, or another appliance is defective.</p> <ul style="list-style-type: none"> ■ Unplug the coffee machine from the socket. ■ Contact a qualified electrician or Miele Service.
<p>The lighting remains off after the coffee machine has been switched on.</p>	<p>The lighting has been switched off.</p> <ul style="list-style-type: none"> ■ Switch the lighting on (see “Settings” – “Lighting”).
	<p>The lighting is faulty.</p> <ul style="list-style-type: none"> ■ Contact Miele Service.
<p>The coffee machine does not respond to operation via the display.</p>	<p>A fault has occurred.</p> <ul style="list-style-type: none"> ■ Touch and hold the On / Off button ① until the display switches off and the machine restarts.
<p>The coffee machine turns off suddenly.</p>	<p>The factory-set switch-off time (20 minutes) or the switch-off time you have programmed has been reached.</p> <ul style="list-style-type: none"> ■ If required, you can select a new switch-off time (see “Settings – Timer”).
	<p>The plug is not inserted in the socket correctly.</p> <ul style="list-style-type: none"> ■ Insert the plug into the socket.
<p>The sensor buttons do not respond. The coffee machine can no longer be operated.</p>	<p>There is an internal fault.</p> <ul style="list-style-type: none"> ■ Disconnect the coffee machine from the electricity supply by removing the plug from the socket or switching off the breaker.
<p>A fan can be heard even though no drinks are being prepared and the coffee machine is switched off.</p>	<p>This is not a fault.</p> <p>Once a drink has been dispensed or the machine has been switched off, the internal fan will continue to run until the interior is sufficiently dehumidified.</p>

Frequently Asked Questions

Problem	Possible cause and solution
<p>The brew unit cannot be removed.</p>	<p>The brew unit is not positioned correctly.</p> <ul style="list-style-type: none"> ■ If necessary, turn the handle on the brew unit back to the start position. Close the appliance door. ■ Switch the coffee machine off. ■ Wait approx. 1 minute before switching the coffee machine back on. <p>This will initialize the brew unit drive and put it back into the start position.</p> <ul style="list-style-type: none"> ■ If necessary, repeat these steps.
<p>Drink dispensing is prematurely aborted even though there is a container under the central spout.</p>	<p>This is not a fault.</p> <p>If the container has a very wide opening that prevents the cup rim sensor from making contact with the edge of the container (e.g., in the case of a very large cup), the drink will be cancelled. Use a different container or position the existing one so that the sensor can detect the rim.</p>
<p>Coffee dispensing is repeatedly interrupted and the message <small>Fill the bean container</small> appears in the display.</p>	<p>This is not a fault.</p> <p>The brew unit has not detected the ground coffee. Certain types of coffee produce a small amount of coffee when they are ground. In such cases, the grinder is usually set to fine and the minimum quantity of coffee is set.</p> <ul style="list-style-type: none"> ■ Confirm the message with <i>OK</i>. <p>If the display appears with all types of coffee:</p> <ul style="list-style-type: none"> ■ Set the grinder to a coarser setting (see “Grinder setting”). ■ Select a larger quantity of coffee. <p>Don’t forget to check any drinks changed in “Profiles”.</p> <p>If the message only appears when dispensing certain drinks:</p> <ul style="list-style-type: none"> ■ Check the quantity of coffee set for this drink (see “Quantity of coffee”). Select a larger quantity of coffee. ■ You may also need to set a coarser grinder setting.

Frequently Asked Questions

Problem	Possible cause and solution
<p>The coffee machine does not switch itself on even though the setting has been activated for the timer.</p> <p>Turn on at</p>	<p>The system lock is activated.</p> <ul style="list-style-type: none"> ■ Deactivate the system lock. <p>The current day of the week has not been selected.</p> <ul style="list-style-type: none"> ■ Check the timer settings and change these if necessary. <p>The coffee machine was not used after being switched on automatically three times in succession (vacation mode).</p> <ul style="list-style-type: none"> ■ Switch the machine on and dispense a drink.
<p>Steam is dispensed instead of water while preparing hot water or making tea.</p>	<p>It is likely that the wrong altitude has been set.</p> <ul style="list-style-type: none"> ■ Change the altitude settings (Settings Altitude). ■ If necessary, you can also change the temperature settings for the drinks (Parameters).
<p>The display is hard to see or not legible.</p>	<p>The display brightness has been set too low.</p> <ul style="list-style-type: none"> ■ Change this setting (see “Settings”).
<p>The display lights up but the coffee machine does not heat up and no drinks are made.</p>	<p>The demo mode for demonstrating the coffee machine in stores and showrooms has been activated.</p> <ul style="list-style-type: none"> ■ Deactivate Demo mode (see “Settings”).

Frequently Asked Questions

Unsatisfactory results

Problem	Possible cause and solution
The coffee is not hot enough.	The cup has not been pre-heated. The smaller the cup and the thicker its sides, the more important it is to pre-heat it. ■ Pre-heat the cup with hot water, for example.
	The brewing temperature is set too low. ■ Set a higher brewing temperature.
	The filters in the brew unit are blocked. ■ Remove the brew unit and clean it by hand. ■ Degrease the brew unit.
The coffee grinder makes a louder noise than usual.	The coffee bean container has become empty during the grinding process. ■ Fill the coffee bean container with fresh beans.
	There may be foreign objects such as plastic or stones in amongst the coffee beans. ■ Switch the coffee machine off immediately. Contact the Service department.
The coffee is dispensed too slowly into the cup.	The brew unit is blocked. ■ Degrease the brew unit (see “Cleaning and care – Degreasing the brew unit and cleaning the interior”).
The crema on the coffee or espresso is not as it should be.	The coffee beans are no longer fresh. If roasted coffee beans are stored open for too long, the carbon dioxide gradually escapes from the coffee beans. The crema is no longer formed during dispensing. Of course, you can still use the coffee beans.

Frequently Asked Questions

Problem	Possible cause and solution
<p>The coffee tastes weak. The coffee grounds in the grounds container are sludgy and grainy.</p>	<p>Too little coffee is being brewed because insufficient coffee beans are getting into the grinder. Have you used a dark roast? This type of coffee bean is often more oily. These oils can cling to the walls of the coffee bean containers and hinder the flow of beans. Are you using a type of coffee with very large beans or different sized beans? The beans are possibly getting wedged or jammed and forming “bean bridges”.</p> <ul style="list-style-type: none"> ■ Clean the coffee bean containers more often if you are using darker, more oily coffee beans. ■ If you are using a type of coffee with very large beans or different sized beans, pull the bean containers out slightly and give them a shake. ■ If necessary, try using a different type of coffee.
<p>Coffee is not being dispensed from both spouts evenly. Milk sometimes sputters during preparation.</p>	<p>Coffee deposits in the central spout are obstructing dispensing.</p> <ul style="list-style-type: none"> ■ Take the central spout apart and wash all the components – with the exception of the stainless steel cover – in the dishwasher. This cleaning operation should be performed once a week.
<p>The consistency of the milk froth is unsatisfactory.</p>	<p>The milk temperature is too high. Good milk froth can only be achieved with cold milk (< 50°F (10°C)).</p> <ul style="list-style-type: none"> ■ Check the temperature of the milk in the milk container. <hr/> <p>The milk pipework is blocked and / or the milk valve is soiled.</p> <ul style="list-style-type: none"> ■ Remove and clean the milk valve.

Service and warranty

Contact in the event of a fault

In the event of a fault which you cannot remedy yourself, please contact your Miele dealer or Miele Service.

Contact information for Miele Service can be found at the end of this document.

Please quote the model identifier and serial number of your appliance (SN) when contacting Miele Service. This information can be found on the data plate.

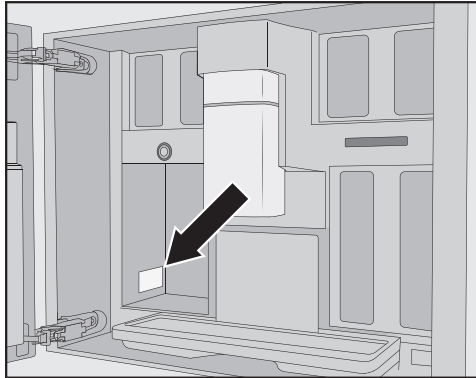

Warranty

For further information, please refer to your warranty booklet.

These products and other useful accessories can be ordered via the Miele online shop, from Miele Service, or from your Miele dealer.

- **Milk pipework cleaner**
For cleaning the milk system
- **Cleaning tablets**
For degreasing the brew unit
- **Descaling tablets**
For descaling the water lines
- **CJ Jug 1.0 l**
Insulated flask for coffee or tea (pot function)
- **Miele Black Edition One for all**
perfect for making espresso, café crema, and specialty coffee with milk
- **Miele Black Edition Espresso**
Whole coffee beans – perfect for making espresso
- **Miele Black Edition Coffee Crema**
Whole coffee beans – perfect for making coffee
- **Miele Black Edition Decaffeinated**
Whole coffee beans – perfect for making decaffeinated specialty coffees

Caring for the environment

Disposal of the packaging material

The cardboard box and packaging materials protect the appliance during shipping. They have been designed to be biodegradable and recyclable.

Recycling the packaging reduces the use of raw materials in the manufacturing process and also the amount of waste.

Disposal of your old appliance

Electronic and electrical appliances contain many valuable materials. They also contain certain materials, compounds and components which were essential for the proper functioning and safe use of the equipment. These could be hazardous to your health and to the environment if disposed of with general waste or if handled incorrectly. Therefore, please do not dispose of your old appliance with general waste.



Consult with local authorities, dealers or Miele in order to dispose of and recycle electrical and electronic appliances. Miele assumes no responsibility for deleting any personal data left on the appliance being disposed. Please ensure that your old appliance is kept away from children until removal. Observe safety requirements for appliances that may tip over or pose an entrapment hazard.

Electrical connection

Before connecting the coffee machine, make sure that the connection data on the data plate (voltage and frequency) matches that of the domestic electrical supply.

This data must match to prevent the coffee machine from being damaged. If in any doubt, consult a qualified electrician.

The necessary connection data is given on the data plate inside your appliance.

The fuse rating must be at least 10 A.

If possible, the socket should remain easily accessible. If the socket is no longer accessible after installation, an additional means of disconnection must be provided for all poles. Suitable means of disconnection include switches with an all-pole contact gap of at least 3 mm. These include circuit breakers, fuses, and contactors (EN 60335).

Do not connect the coffee machine to a **stand-alone inverter**. Stand-alone inverters are used for autonomous power supply, e.g., a solar power system. Power surges could trigger the safety shut-off function. This can damage the electronics.

The coffee machine must not be used with **energy-saving plugs**. These reduce the amount of energy supplied to the appliance, causing it to overheat.

Installation

Installation dimensions

Installation in a tall cabinet

A minimum installation height of 850 mm must be observed.

All dimensions are indicated in mm.

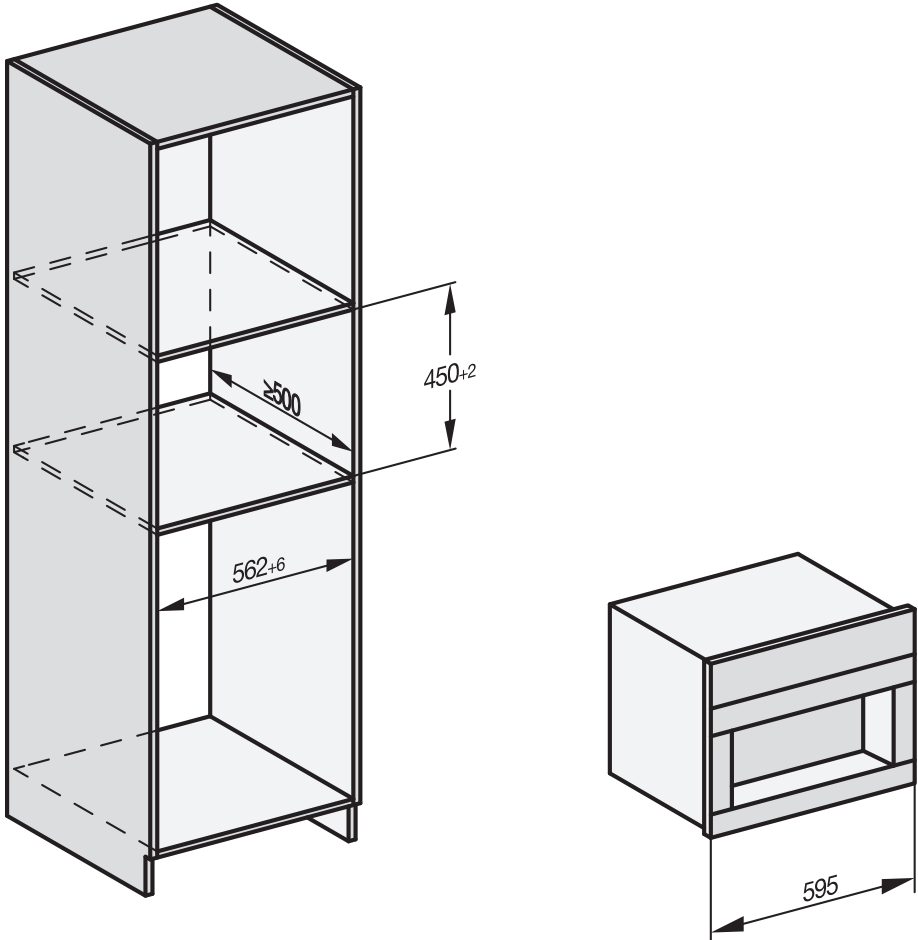

Combination with other Miele Built-in Appliances is possible. If the coffee machine is to be built in above another appliance, there must be a full-width, closed shelf between them. If the machine is to be combined with a suitable built-in dishware / food-warming drawer, no shelf is required in between.

Installation and connections

All dimensions are indicated in mm.

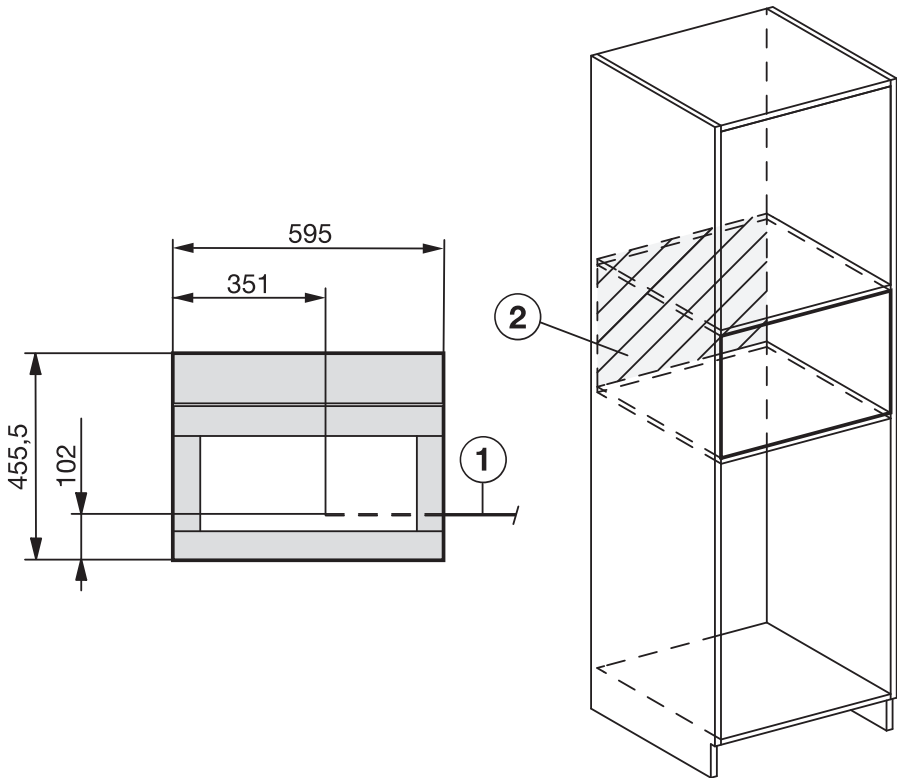

- A** Cut-out (at least 20" / 508 mm wide) in the niche floor of the tall cabinet for power cord and ventilation
- E** Electrical connection
- ⓘ No electrical or fresh water connection in this area

Installation

Building in the coffee machine

 Danger of injury due to incorrect operation.

A machine that has not been built in is not safe and can cause injuries.

Do not operate the coffee machine unless it has been built in.

 Danger of damage due to incorrect operation.

If the ambient temperature range is not observed, the coffee machine may not function properly.

The coffee machine may only be operated within an ambient temperature range of +16°C to +38°C.

A minimum installation height of 850 mm must be observed.

A door opening angle of 120° must be ensured so that you can remove the left-hand bean container.

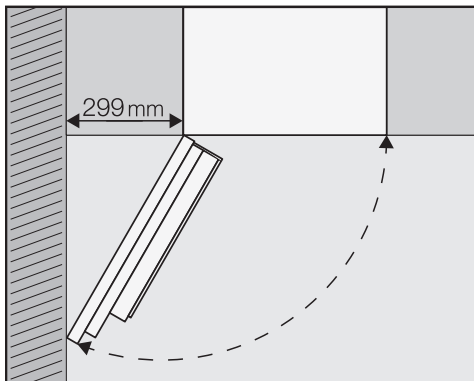

Check that there is a gap of at least 299 mm between the wall (or similar) and the coffee machine so that you can

open the door wide enough to remove the left-hand bean container (minimum door opening angle of 120°).

To install the machine, you will need a TX 20 screwdriver.

Removing transport restraint

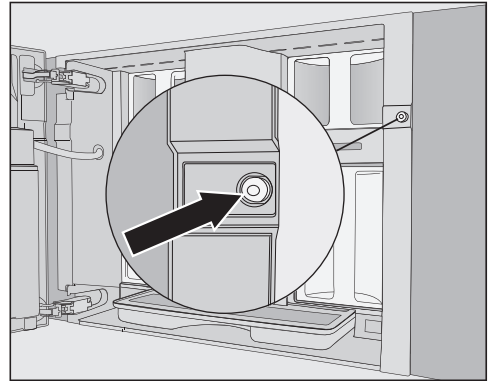

1 screw hole is fitted with a red silicone plug to protect the appliance against transport damage and secure the door during transport.

Remove the plug **before** screwing the coffee machine to the cabinet unit.

- Pull firmly on the red silicone plug to remove them from the screw holes.

The plug is not required for any other purpose. Dispose of its with your household waste.

Useful tip: We recommend providing a place to sit the coffee machine which is the same height as the building-in niche. This will make it easier to connect the appliance to the electricity supply.

Connecting the electricity supply

Observe the information under “Electrical connection”.

- Connect the coffee machine to the electricity supply.

Pushing in and aligning the coffee machine

Take care not to trap or damage the electrical connection when pushing the machine into the niche.

- Push the coffee machine all the way into the niche until you feel a resistance.
- Check the height of the coffee machine to make sure that it is sitting centrally in the niche and that it is level. Align the appliance if necessary.

Never align the coffee machine by adjusting the door hinges. This will prevent the milk container from attaching correctly and interfere with the milk preparation process.

Now screw the coffee machine to the housing unit.

- Open the appliance door.

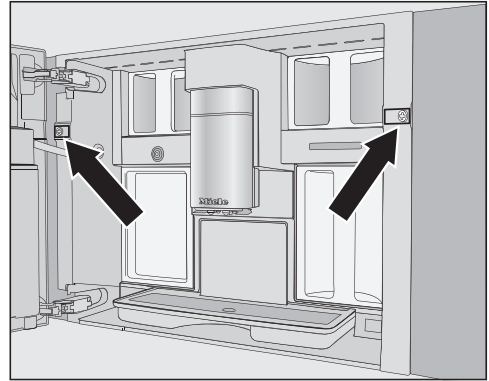

Two TX20 (25 mm) screws are included with the machine.

- Secure the coffee machine to the side walls of the housing unit using the screws supplied. Tighten both screws by hand.

Useful tip: To make it easier to attach the screw on the left, you can remove the door opening limiters and increase the door opening angle to approx. 170° (see “Door opening limiters”). Make sure that there is sufficient space available and that the appliance door is not going to hit an adjacent wall.

- Carry out a functional check on the coffee machine.

Door opening limiters

The coffee machine door hinges are equipped with door opening limiters that restrict the opening angle of the door to approx. 120°. This will prevent the door from hitting an adjacent wall and being damaged when opened.

Installation

The door opening limiters can be removed, allowing you to increase the opening angle to approx. 170°. This makes it easier to remove the bean containers, for example.

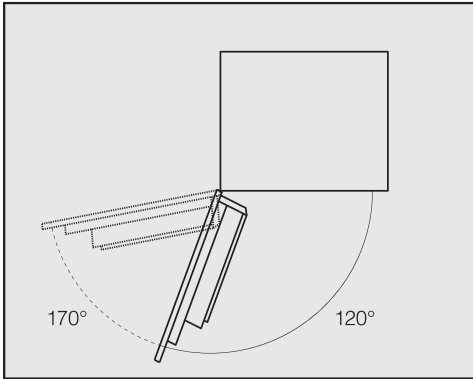

Removing the door opening limiters

Make sure that sufficient space is available for the larger door opening angle and that the door is not going to hit an adjacent wall.

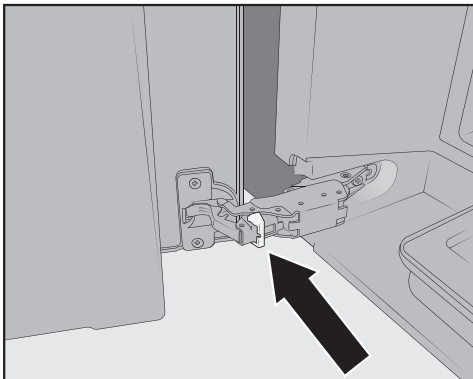

- Remove the door opening limiters from the hinges, e.g., by prizing them out with a screwdriver.

The door opening angle has now been increased to approx. 170°.

FCC Declaration of Conformity

Electricity consumption in standby:	< 0,6 W
Electricity consumption in networked standby:	< 0,9 W
Frequency range	2.412 GHz – 2.462 GHz
Maximum transmitting power	< 100 mW



WiFi module EK037

Contains FCC ID: 2ACUWEK037

Contains IC: 5669C-EK037

This device complies with Part 15 of the FCC Rules and with Industry Canada licence-exempt RSS standard(s). Operation is subject to the following two conditions: (1) this device may not cause harmful interference, and (2) this device must accept any interference received, including interference that may cause undesired operation.

This equipment complies with FCC radiation exposure limits set forth for an uncontrolled environment. This equipment should be installed and operated with minimum distance 8" (20 cm) between the radiator and your body. This device and its antenna(s) must not be co-located or operation in conjunction with any other antenna or transmitter.

Industry Canada Statement

This digital apparatus does not exceed the Class B limits for Radio Noise Emissions from digital apparatus set out in the Radio Interference Regulations of the Canadian Department of Communications.

Complies with Canadian ICES-003 Class B specifications.

**Please have the model and serial number
of your appliance available when
contacting Customer Service.**

**Canada
Importer
Miele Limited**

Headquarters and Miele Centre

161 Four Valley Drive
Vaughan, ON L4K 4V8
www.miele.ca

Customer Care Centre

Phone: 800 565-6435
customercare@miele.ca

**Germany
Manufacturer**

Miele & Cie. KG
Carl-Miele-Straße 29
33332 Gütersloh

CVA 7440

en-CA

M.-Nr. 11 822 950 / 01