

705-LE1000-00

合格证
QC PASS

深圳市神牛摄影器材有限公司

地址: 深圳市宝安区福海街道塘尾社区耀川工业区厂房2栋
电话: 0755-29609320(8062) 传真: 0755-25723423 邮箱: godox@godox.com

GODOX Photo Equipment Co., Ltd.

Add: Building 2, Yaochuan Industrial Zone, Tangwei Community, Fuhai Street, Bao'an District,
Shenzhen, China Tel: +86-755-29609320(8062) Fax: +86-755-25723423
E-mail: godox@godox.com

godox.com

Made in China



Godox

LED摄影灯
LED Video Light

LED1000



说明手册

INSTRUCTION MANUAL



一、前言

感谢您购买神牛产品!

LED1000系列摄影灯灯珠数量多,光线均匀柔和,无热辐射,非常适用于影棚拍摄、采访布光、静物拍摄以及视频拍摄等。此灯具具有三种型号: **LED1000W**白光版(5600K)、**LED1000Y**黄光版(3300K)、**LED1000C**变色版(3300K~5600K),配备专用遥控器,可无线分组调光,无线调节亮度与色温,功能丰富,操作便捷。

产品具有以下特点:

- 1024颗优质灯珠亮度高,照幅广
- 白光版、黄光版、变色版三种型号可供选择
- 433MHz无线6组16频道分组控制
- 锂电池或DC供电,拍摄更省心
- 大液晶屏,参数自动保存

类型	型号
白光版 (色温5600K)	LED1000W
黄光版 (色温3300K)	LED1000Y
变色版 (色温3300K~5600K)	LED1000C

二、注意事项

- ⚠ 请勿将摄影灯放置在高温、高湿的地方。
- ⚠ 此机有温度保护功能,当温度过高时进入保护状态,当温度降低后恢复正常。
- ⚠ 请勿用湿手接触产品,亦不可将产品浸入水中或暴露于雨中。
- ⚠ 使用电池的注意事项:
 - 切勿将电池投入火中或加热升温。
 - 当电量用尽时,电池容易漏液。所以为了避免产品受损,请在长期不使用本产品或电量用尽时取出电池。
 - 如果受损电池中的液体接触到皮肤或衣服,请立即用大量清水冲洗。

三、部件

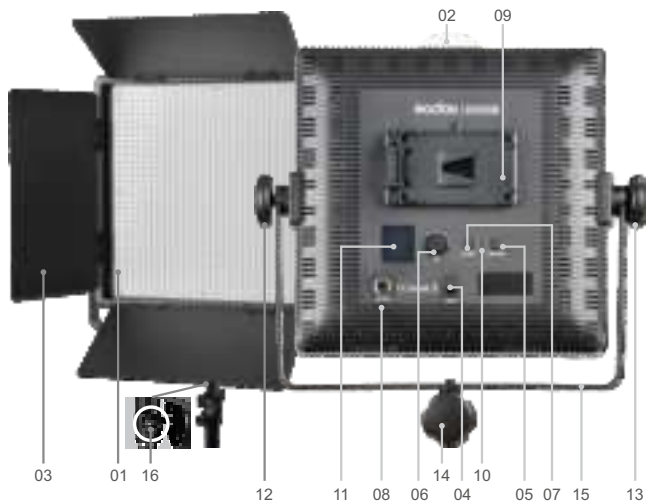

- | | | |
|----------------|----------------|-----------|
| 01. 1024粒灯珠 | 07. CH/GRP按钮 | 13. 旋钮B |
| 02. 色温片 | 08. DC电源插座 | 14. 旋钮C |
| 03. 挡光板 | 09. 锂电池插槽 | 15. 托架 |
| 04. ON/OFF开关 | 10. 电源指示灯 | 16. 支架安装孔 |
| 05 STOP/RUN按钮 | 11. LCD屏(蓝底白字) | 17. 电源适配器 |
| 06. 调节旋钮+SET按钮 | 12. 旋钮A | 18. 电源线 |

四、电源管理

1. 供电方式

LED1000摄影灯有2种供电方式：



- 锂电池供电
请选择SONY 锂电池BP-L系列电池（需自行购买），放置于锂电池插槽内。



- 直流电源供电
请选择13~16.8V电源适配器（标配），与DC电源插座(08)连接。

注：

- 使用锂电池供电时，LCD显示当前剩余电量。当电量符号闪烁时，表示锂电池电量极低。为了防止LED灯自动强行熄灭，请及时对锂电池充电后再使用。

2. 安装锂电

- 关闭电源开关(04)。
- 将锂电池带插孔端对准摄影灯锂电池插槽正负极触点，并推进卡紧。
- 打开电源开关(04)即可。
- 使用完毕，请关闭电源开关(04)。

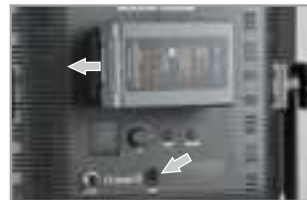

五、固定摄影灯

- 转动摄影灯的旋钮C(14)至最高点，将灯架固定在支架安装孔(16)上。
- 扭紧旋钮C(16)。

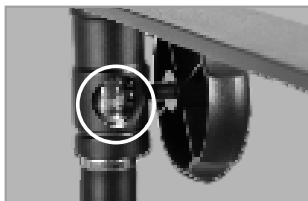

六、操作说明

1. 开始使用摄影灯(见图)

- 插入锂电池或者DC电源。
- 按ON/OFF开关，电源指示灯点亮，摄影灯开始发光。
- 按STOP/RUN开关，控制摄影灯点亮和关闭。
- LCD显示主机当前信息

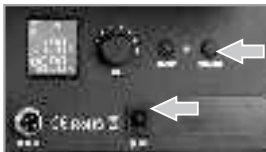

2. 亮度/色温调节

亮度调节

- 在常态时，旋转主机上的调节旋钮可对亮度进行调整；
- 不同色温对应不同亮度范围：

型号	色温	亮度范围
黄光版 LED1000Y	3300K	10%~100%
白光版 LED1000W	5600K	
变色版 LED1000C	3300K/5600K	10%~100%
	3400K~5500K	25%~100%

色温调节

- 在常态时，按旋钮上的SET按钮1次，此时色温值闪烁，旋转调节旋钮可对色温调整；
- 色温显示范围：

白光版 LED1000W	黄光版 LED1000Y	变色版 LED1000C
5600K	3300K	3300K~5600K

注：恒温版无法调节色温，LCD显示3300K或者5600K。

3. 无线远程控制(遥控器另购)

本产品具备无线遥控功能，使用433MHz无线技术，无视角限制，距离远，可同时分别控制6个LED灯，16组通道频率，抗干扰强。

使用前请把LED主机和遥控器的频道与组别调至一致。

主机频道/组别调整

- 在常态时，按CH/GRP按钮，此时组别闪烁，旋转调节旋钮可选择组别(A-F)；
- 在常态时，按CH/GRP按钮2次，此时频道闪烁，旋转调节旋钮可选择频道(1~16)；

遥控器频道/组别调整

- 在常态时，按CH/GRP按钮，此时组别闪烁，按“-”“+”按钮可选择组别(A-F)；
- 在常态时，按CH/GRP按钮2次，此时频道闪烁，按“-”“+”按钮可选择频道(1~16)；

遥控器亮度/色温参数调节

- 在常态时，按“-”“+”按钮可对亮度调整；
- 在常态时，按SET按钮1次，此时色温值闪烁，按“-”“+”按钮可对色温调整。

注：主机在开机状态下才可以接收无线信号。

其他操作说明

- 按遥控器的ON/OFF按键，可打开或者关闭所有组别的LED灯。
- 长按遥控器“SET”按钮2秒，可打开或者关闭当前组别的LED灯。
- 遥控器开机后4个小时无操作自动关机。

遥控器使用提示：

- (1)使用白光版时，请把遥控器的色温值固定在5600K；
- (2)使用黄光版时，请把遥控器的色温值固定在3300K；
- (3)长时间不使用，请取出电池。

4. 滤色片更换(见图)

- 用手轻轻捏住色温片(02)向上拉出。
- 将新色温片直接插入，向下推移，色温片更换完毕。



七、标配物品

序号	包含物品	LED1000W(5600K)	LED1000Y(3300K)	LED1000C(3300K~5600K)
1	LED摄影灯	1个	1个	1个
2	电源适配器	1个	1个	1个
3	电源线	1条	1条	1条
4	柔光片	1个	1个	1个
5	黄色滤色片	1个	无	无
6	蓝色滤色片	1个	无	无



LED摄影灯



电源适配器



电源线

八、产品参数

LED灯	白光版LED1000W	黄光版LED1000Y	变色版LED1000C
锂电池供电	14.8V锂电池 (BP-L接口) (需另购)		
DC电源供电	13~16.8V		
频道	16个		
组别	6组 (A, B, C, D, E, F)		
功率	最大70W		
色温	5600K±300K	3300K±300K	3300K~5600K ±300K
100%光照度 (LUX)	4400(1米)	4400(1米)	4400 (1米/4200K) 2200 (1米/3300K) 2200 (1米/5600K)
调光范围	10%~100%	10%~100%	3300K/5600K :10%~100% 3400K~5500K :25%~100%
灯珠数量	1024个	1024个	5600K: 512个 3300K: 512个
工作环境温度	-10~50度		
产品尺寸	430*460*100mm		
净重	2.44kg		

设计和规格如有变更，恕不另行通知。

Foreword

Thank you for purchasing this Godox product!

This LED1000 video light is excellent for product shooting, photojournalistic and video recording, etc. It provides a wide spectrum, beautifully soft and even illumination for photography. Three models are available: LED1000W White Version (5600K), LED1000Y Yellow Version (3300K), and LED1000C Changeable Version (3300K~5600K).

Features:

- 1024-LED-bulbs panel is lithium-ion or DC powered
- Three versions to offer more choices
- Wirelessly adjust brightness or color temperature
- Wireless 433MHz grouping system (6 groups & 16 channels)
- Large-sized LCD panel. Settings auto saved.

Type	Model
White Version(Color Temperature 5600K)	LED1000W
Yellow Version(Color Temperature 3300K)	LED1000Y
Changeable Version(Color Temperature 3300K~5600K)	LED1000C

For your safety

- ⚠ Do not place in high temperature or high humidity conditions.
- ⚠ If this product overheats, it will cease operation and resume working after cooling down. This is due to the built-in overtemperature protection.
- ⚠ Do not handle with wet hands, immerse in water, or expose to rain.
- ⚠ Observe precautions when handling batteries:
 - Do not mix new and used batteries or batteries of different types.
 - Do not put batteries into a fire or apply direct heat to it.
 - Batteries are prone to leakage when fully discharged. To avoid damage to the product, be sure to remove batteries out when the product will not be used for a long time or when batteries run out of charge.
 - Should liquid from batteries come into contact with skin or clothing, rinse immediately with fresh water.

Parts

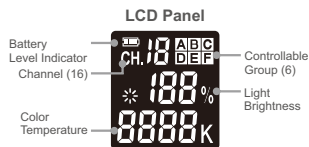
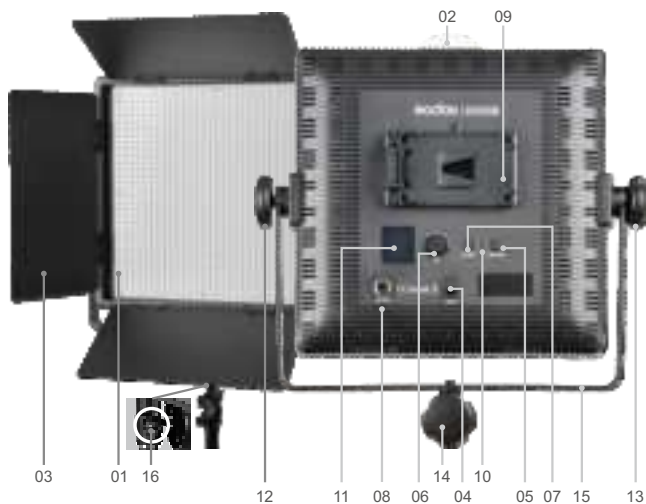

- | | | |
|------------------------------|---------------------------------|---------------------------|
| 01. 1024 LED Beads | 08. DC Power Jack | 14. Knob C |
| 02. Color Filters | 09. Lithium Battery Compartment | 15. Bracket |
| 03. Reflector | 10. Power Indicator | 16. Bracket Mounting Hole |
| 04. ON/OFF Power Switch | 11. LCD Panel (White in Blue) | 17. Power Adapter |
| 05. STOP/RUN Button | 12. Knob A | 18. Power Cord |
| 06. Select Dial + SET Button | 13. Knob B | |
| 07. CH/GRP Button | | |

Power Management

1. Power Supply

Two power supply modes are available:



- Using lithium battery: This light uses SONY BP-L model lithium battery (purchased separately).
- Using DC power jack: This light can be powered by DC power supply. Use a 13~16.8V adapter (included) to connect the light with the DC power jack (08).

Note:

- When using lithium battery, the Battery Level Indicator is displayed on the LCD panel. When the indicator blinks, the lithium battery power is low. Please recharge it immediately before usage in order to avoid forceful auto off.

2. Installing Lithium Battery

- Turn the Power Switch (04) off.
- Target the socket of the lithium battery towards the "+" "-" contacts of the Battery Compartment (09). Push the battery in until it locks.
- Power the light on.
- After using the light, please power it off.

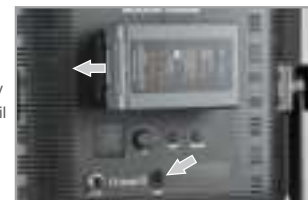

Using the Video Light

- Screw the Knob C (14) to the highest point and install the light stand onto the Bracket Mounting Hole (16).
- Tighten the Knob C (14).

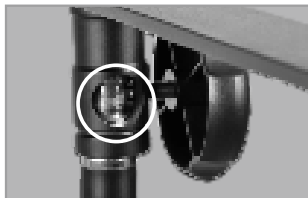

Operation

1. Before Usage

- Insert the lithium battery or connect the light with the DC power supply.
- Switch the power on, the Power Indicator (10) is on and the video light giving out light.
- Press the STOP/RUN Button to control the video light on and off
- LCD panel shows the information.



2. Light Brightness/Color Temperature Adjustment

Adjusting Light Brightness

- Turn the select dial to adjust the light brightness.

The light brightness adjustable range changes at different color temperature with different models.

Model	Color Temperature	Light Brightness Range
LED1000Y	3300K	10%~100%
LED1000W	5600K	
LED 1000C	3300K/5600K	10%~100%
	3400K~5500K	25%~100%

Adjusting Color Temperature

- Press the SET button once and the color temperature icon blinks. Turn the select dial to adjust color temperature.

Color temperature range:

White Version	Yellow Version	Changeable Version
LED1000W	LED1000Y	LED1000C
5600K	3300K	3300K~5600K

NOTE:Color temperature of LED1000W or LED1000Y is invariable. The LCD panel only shows 5600K or 3300K.

3. Wireless Remote Control

With 433 MHz wireless system, this product has remote grouping and control function. Up to 6 groups of LED light can be controlled. 16 channels are available with strong anti-interference capability.

Please set the channels and groups of LED video light to the same as those of remote control before usage.

Adjusting Channel/Group of the LED Video Light

- Press the CH/GRP button and the group icon blinks. Turn the select dial to choose a group ID (A to F).
- Press the CH/GRP button twice and the channel icon blinks. Turn the select dial to choose a channel ID (1 to 16).

Adjusting Channel/Group of the Remote Control

- Press the CH/GRP button and the group icon blinks. Press the "+" "-" button to choose a group ID (A to F).
- Press the CH/GRP button twice and the channel icon blinks. Press the "+" "-" button to choose a channel ID (1 to 16).

Adjusting Light Brightness/Color Temperature with the Remote Control

- Press the "+" "-" button to adjust the light brightness.
- Press the SET button of the remote control once and the color temperature icon blinks. Press the "+" "-" button to adjust the color temperature.

Note: The wireless signal can be received only when the LED light is power on. Remote control purchased separately.

Other Operation Tips:

- Pressing the ON/OFF button on the remote control can turn on/off all the LED groups.
- Pressing the "SET" button on the remote control for 2 seconds can turn on/off the current LED group.
- The remote control will auto power off after four hours of idle operation.

Tips of Using Remote Control:

- (1)When using the White Version LED1000W, please set the color temperature of the remote control as 5600K constantly;
- (2)When using the Yellow Version LED1000Y, please set the color temperature of the remote control as 3300K constantly;
- (3)Please remove the battery if the light will not be used for an extended period of time.of time.

4. Replacing A Color Filter

- Pinch the edge of the color filter (02) and pull it out upwardly.
- Insert a new color filter in and push it downwardly.
Then the color filter is securely in position.



What's in the Box of LED1000?

NO.	Included Item	LED1000W	LED1000Y	LED 1000C
1	LED Video Light	1 PC	1 PC	1 PC
2	Power Adapter	1 PC	1 PC	1 PC
3	Power Cord	1 PC	1 PC	1 PC
4	Diffusion Filter	1 PC	1 PC	1 PC
5	Yellow Filter	1 PC	NO	NO
6	Blue Filter	1 PC	NO	NO



Power Adapter



Power Cord



LED Video Light

Technical Data

LED1000 Video Light	White Version LED1000W	Yellow Version LED1000Y	Changeable Version LED1000C
Lithium Battery	14.8V Lithium Battery(SONY BP-L model lithium battery) (sold separately)		
DC Power Supply	13~16.8V		
Channel	16		
Group	6 groups(A,B,C,D,E,F)		
Power	Max. 70W		
Color Temperature	5600K±300K	3300K±300K	3300K~5600K ±300K
Brightness(LUX)	4400(1m)	4400(1m)	4400 (1m/4200K)
			2200 (1m/3300K)
			2200 (1m/5600K)
Light Brightness Range	10%~100%	10%~100%	3300K/5600K :10%~100%
			3400K~5500K :25%~100%
LED Beads Quantity	1024	1024	5600K : 512
			3300K : 512
Operation Temperature	-10~50 °C		
Dimension	430*460*100mm		
Net Weight	2.44kg		

* Product design and specifications are subject to change without notice.

FCC Statement

This device complies with part 15 of the FCC Rules. Operation is subject to the following two conditions: (1) This device may not cause harmful interference, and (2) this device must accept any interference received, including interference that may cause undesired operation.

Note: This equipment has been tested and found to comply with the limits for a Class B digital device, pursuant to part 15 of the FCC Rules. These limits are designed to provide reasonable protection against harmful interference in a residential installation. This equipment generates uses and can radiate radio frequency energy and, if not installed and used in accordance with the instructions, may cause harmful interference to radio communications. However, there is no guarantee that interference will not occur in a particular installation. If this equipment does cause harmful interference to radio or television reception, which can be determined by turning the equipment off and on, the user is encouraged to try to correct the interference by one or more of the following measures:

- Reorient or relocate the receiving antenna.
- Increase the separation between the equipment and receiver.
- Connect the equipment into an outlet on a circuit different from that to which the receiver is connected.
- Consult the dealer or an experienced radio/TV technician for help.

产品保修

尊敬的用户，本保修卡是申请维修服务的重要凭证，请您配合销售商填写并妥善保管，谢谢！

产品信息	型号	产品条码
用户信息	姓名	联系电话
	通信地址	
销售商信息	名称	
	联系电话	
	通信地址	
	销售日期	
备注		

注：此表应由销售商盖章确认。

如何获得保修服务

要维修服务，您可直接与产品销售商或授权服务机构联系，也可拨打神牛产品售后服务电话，与我们联系，由我们的服务人员为您安排服务。申请保修时，您应提供有效的保修卡作为保修凭证，方可获得保修。如您不能提供有效的保修卡，则在我们可确认产品或部件属于保修范围的情况下，也可以为您提供保修，但这不作为我们的义务。

不适用保修的情况

如产品存在下列情况，本文件项下的保证和服务将不适用 ①产品或部件超过相应保修期；②错误或不适当使用、维护或保管导致的故障或损坏，如：不当搬运；非按产品合理预期用途使用；不当插拔外接设备；跌落或外力挤压；接触或暴露于不当温度、溶剂、酸碱、水浸或潮湿环境；③由非神牛授权机构或人员安装、修理、更改、添加或拆卸造成的故障或损坏；④产品或部件原有识别信息被修改变更或删除；⑤无有效保修卡；⑥使用非合法授权、非标准或非公开发行的软件造成的故障或损坏；⑦因不可抗力或意外事件造成的故障或损坏；⑧其他非因产品本身质量问题导致的故障或损坏。遇上述情况，您应向相关责任方寻求解决，神牛对此不承担任何责任。因非在保修期或保修范围内的部件、附件或软件导致产品不能正常使用的，不是保修范围内的故障。产品使用过程中正常的脱色，磨损和消耗，不是保修范围内的故障。

产品保修和服务支持信息

产品的保修期和服务类型按以下《产品保修信息》执行：

产品类别	选项名称	保修期(月)	保修服务类型
部件	电路板	12	客户送修
	电池	3	客户送修
	充电器、电源线、同步线等带电性能的部件。	12	客户送修
其他	如闪光灯、造型灯泡、外壳、保护罩、锁紧装置、包装等。	无	无保修

适用产品

本文件适用于相关《产品保修信息》(见后面说明)所列产品，其他非属此范围的产品或部件(如促销品、赠品及其他出厂后附加的部件等)不在此保修承诺内。

保修期

产品及部件的相应保修期按相关的《产品保修信息》执行。保修期自产品首次购买日起算，购买日以购买产品时保修卡登记日期为准。

神牛产品售后服务电话 0755-29609320-8062

Warranty

Dear customers, as this warranty card is an important certificate to apply for our maintenance service, please fill in the following form in coordination with the seller and safekeep it. Thank you!

Product Information	Model	Product Code Number
Customer Information	Name	Contact Number
	Address	
Seller Information	Name	
	Contact Number	
	Address	
	Date of Sale	
Note:		

Note: This form shall be sealed by the seller.

Warranty Period

The warranty period of products and accessories is implemented according to the relevant Product Maintenance Information. The warranty period is calculated from the day (purchase date) when the product is bought for the first time. And the purchase date is considered as the date registered on the warranty card when buying the product.

How to Get the Maintenance Service

If maintenance service is needed, you can directly contact the product distributor or authorized service institutions. You can also contact the Godox after-sale service call and we will offer you service. When applying for maintenance service, you should provide valid warranty card. If you cannot provide valid warranty card, we may offer you maintenance service once confirmed that the product or accessory is involved in the maintenance scope, but that shall not be considered as our obligation.

Inapplicable Cases

The guarantee and service offered by this document are not applicable in the following cases: ①. The product or accessory has expired its warranty period; ②. Breakage or damage caused by inappropriate usage, maintenance or preservation, such as improper packing, improper usage, improper plugging in/out external equipment, falling off or squeezing by external force, contacting or exposing to the improper temperature, solvent, acid, base, flooding and damp environments, etc; ③. Breakage or damage caused by non-authorized institution or staff in the process of installation, maintenance, alternation, addition and detachment; ④. The original identifying information of product or accessory is modified, alternated, or removed; ⑤. No valid warranty card; ⑥. Breakage or damage caused by using illegally authorized, nonstandard or non-public released software; ⑦. Breakage or damage caused by force majeure or accident; ⑧. Breakage or damage that could not be attributed to the product itself. Once met these situations above, you should seek solutions from the related responsible parties and Godox assumes no responsibility. The damage caused by parts, accessories and software that beyond the warranty period or scope is not included in our maintenance scope. The normal discoloration, abrasion and consumption are not the breakage within the maintenance scope.

Maintenance and Service Support Information

The warranty period and service types of products are implemented according to the following Product Maintenance Information:

Product Type	Name	Maintenance Period(month)	Warranty Service Type
Parts	Circuit Board	12	Customer sends the product to designated site
	Battery	3	Customer sends the product to designated site
	Electrical parts e.g.battery charger, power cord, sync cable, etc.	12	Customer sends the product to designated site
Other Items	Flash tube, modeling lamp, lamp body, lamp cover, locking device, package, etc.	No	Without warranty

Godox After-sale Service Call **0755-29609320-8062**

Applicable Products

The document applies to the products listed on the Product Maintenance Information (see below for further information). Other products or accessories (e.g. promotional items, giveaways and additional accessories attached, etc.) are not included in this warranty scope.